



BLUE-MASTER[®]
by *celesa*







END MILLS

2 FLUTE END MILLS

End mills

Pink

2 Z     **INOX** **Al** **TOL D2 h6** Ref. FFAL 

SHORT SERIES

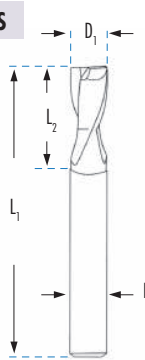



See DIN844 dimensions next pages

DIN 327	MATERIAL COATING QUALITY				FF01	FF02	FF60	FT02	FF92	FP05	FT12	FP08	FT01	DIN 844	FFAL
					HSS	HSSCo 8%	HSSCo 8%	HSSCo 8%	HSSCo 8%	ASP 60	ASP 60	ASP 60	ASP 60		HSSCo 8%
					BRIGHT	BRIGHT	TiAlN	TiAlSiN	BRIGHT	BRIGHT	TiAlSiN	BRIGHT	TiAlSiN		BRIGHT
				★	★★	★★★	★★★★	★★	Premium Quality				★★★★	Al	
D1 mm	L1 mm	L2 mm	D2 mm	TOL e8	TOL e8	TOL e8	TOL e8	TOL h10	TOL e8	TOL e8	TOL h10	TOL h10	TOL h10	TOL e8	€
1,00	47	2,5	6						24,80	32,13	36,16	43,16			
2,00	48	4,0	6	11,27	14,28	23,42	27,31	29,07	20,92	28,56	31,92	39,24		17,27	
2,50	49	5,0	6		14,28	23,42	27,31	30,92						17,62	
3,00	49	5,0	6	11,27	14,28	23,42	27,31	29,21	20,92	28,56	31,92	39,24		17,23	
3,50	50	6,0	6		15,51	24,63	28,69	30,92						18,28	
4,00	51	7,0	6	11,06	14,28	23,43	27,32	29,21	19,02	27,30	31,92	39,24		17,74	
4,50	52	8,0	6	11,06*	17,06	25,99	30,31	30,92						19,42	
5,00	52	8,0	6	11,06	14,28	23,43	27,32	29,21	19,02	27,30	31,92	39,24		17,74	
5,50	52	8,0	6		17,65	26,67	31,09	30,92						21,73	
6,00	52	8,0	6	11,06	14,28	23,43	27,32	29,21	19,02	27,30	31,92	39,24		19,23	
6,50	60	10,0	10	16,49*	23,10	33,42	38,96							28,42	
7,00	60	10,0	10	16,49	22,41	32,71	38,14	35,20	28,70	37,75	42,23	55,85		25,84	
7,50	61	11,0	10		22,20	32,49	37,89							30,30	
8,00	61	11,0	10	13,42	18,46	28,89	33,71	31,35	24,93	37,01	42,23	55,85		23,39	
8,50	61	11,0	10		24,94	36,14	42,14							31,94	
9,00	61	11,0	10	17,15	22,80	34,16	39,82	36,04	30,69	40,77	42,23	57,53		28,95	
9,50	63	13,0	10		24,40	35,36	41,22								
10,00	63	13,0	10	14,11	18,34	29,75	34,87	31,10	27,77	37,72	42,23	57,53		25,28	
10,50	70	13,0	12		29,31	44,51	51,18								
11,00	70	13,0	12		27,83	40,73	47,50	43,92						34,91	
12,00	73	16,0	12	18,44	24,56	37,29	43,48	41,45	35,43	48,68	57,51	73,11		31,71	
13,00	73	16,0	12		35,82	50,22	58,56	54,77						45,19	
14,00	73	16,0	12	26,23	35,82	50,22	58,56	54,77	43,19	59,70	64,99	80,90		44,36	
15,00	73	16,0	12		40,05	56,89	66,35	58,91						48,72	
16,00	79	19,0	16	27,38	35,45	52,21	60,89	59,84	54,07	70,76	75,99	94,40		47,47	
17,00	79	19,0	16		48,12	66,66	77,74							66,05	
18,00	79	19,0	16	35,87	48,12	66,73	77,82	72,88	68,47	84,40	96,32	145,50		59,29	
19,00	79	19,0	16		60,13	80,81	94,26							79,97	
20,00	88	22,0	16		62,94	85,99	100,27								
20,00	88	22,0	20	42,05	56,92	77,76	90,69	87,04	80,65	101,51	112,29	148,61		68,54	
22,00	88	22,0	20	57,68	75,18	103,05	120,16	113,90	102,72	142,39	133,35	170,66		95,41	
24,00	102	26,0	25	72,38	97,02	127,96	149,20	136,12						143,38	
25,00	102	26,0	25	72,40	94,52	122,70	143,08	125,08	137,13	171,56	174,80*	215,98*		121,44	
26,00	102	26,0	25		110,87	169,89	195,34							190,72	
28,00	102	26,0	25	90,70	119,35	159,21	186,56							147,77	
30,00	102	26,0	25	104,35	135,99	176,25	205,52	181,17						170,05	
32,00	112	32,0	32	108,21	139,69	179,48	209,30							180,11	
36,00	112	32,0	32	139,32	186,85	230,56	268,86								
40,00	130	38,0	32	169,38	229,44	285,06	332,43								

*Available until end of stock

2 FLUTE END MILLS

2Z    **INOX** **Al** **TOL D2 h6**  Ref. FFLAL

LONG SERIES







DIN 327/L				MATERIAL	COATING	QUALITY	DIN 844/L					
							FF06	FF67	FT06	FF15	FP21	FFLAL
D1 mm	L1 mm	L2 mm	D2 mm	HSSCo 8%	HSSCo 8%	HSSCo 8%	HSSCo 8%	ASP 60	L1 mm	L2 mm	D2 mm	HSSCo 8%
				BRIGHT	TiAlN	TiAlSiN	BRIGHT	BRIGHT				BRIGHT
				★★	★★★	★★★★	★★	Premium Quality				Al
				TOL e8	TOL e8	TOL e8	TOL h10	TOL h10				TOL e8
				€	€	€	€	€				€
2,00	54	7	6	15,74*	24,82*	28,94*	31,96	37,49*	54	10	6	26,03
2,50	56	8	6	15,82*	24,82*	28,94*	32,00		56	12	6	
3,00	56	8	6	15,74	24,89	29,03	32,00	38,64*	56	12	6	26,16
3,50	59	10	6	17,88	29,56	34,50			59	15	6	
4,00	63	11	6	15,81	24,89	29,03	32,00	38,64	63	19	6	26,32
4,50	63	11	6	17,88	25,42	29,64			63	19	6	
5,00	68	13	6	15,81	24,89	29,03	33,88	40,90*	68	24	6	26,45
5,50	68	13	6	17,88	29,56	34,50			68	24	6	
6,00	68	13	6	15,81	24,89	29,03	30,62	36,95*	68	24	6	27,46
6,50	80	16	10	29,65	48,52	55,79			68	24	6	
7,00	80	16	10	26,10	36,44	42,50	38,62	46,18*	80	30	10	
7,50	88	19	10						80	30	10	
8,00	88	19	10	22,97	33,27	38,82	38,62	46,60*	88	38	10	37,52
8,50	88	19	10	35,16	47,85	55,80			88	38	10	
9,00	88	19	10	30,91	42,14	49,12	42,36		88	38	10	39,57
10,00	95	22	10	25,31	38,54	44,94	42,18	51,16*	95	45	10	37,52
11,00	102	22	12	39,90	53,83	62,76	56,18		102	45	12	52,58*
12,00	110	26	12	36,39	50,90	59,36	55,10	66,21*	110	53	12	48,54
13,00	110	26	12						110	53	12	
14,00	110	26	12	47,96	62,21	72,54	73,10	82,98	110	53	12	55,56
15,00	123	32	16						110	53	12	
16,00	123	32	16	54,97	76,77	89,54	83,20	99,03	123	63	16	67,82
17,00	123	32	16						123	63	16	
18,00	123	32	16	62,81	90,12	105,06	99,99	118,99	123	63	16	83,93
20,00	141	38	20	72,23	98,85	115,28	108,42	129,01	141	75	20	100,11
22,00	141	38	20	99,03	134,14	156,42	134,39	159,94	141	75	20	
24,00	166	45	25	150,70	170,66	196,22	180,78		166	90	25	
25,00	166	45	25	142,06	180,50	210,49	165,29	196,70	166	90	25	
26,00	166	45	25	188,64	200,96	231,06			166	90	25	
28,00	166	45	25	172,15	219,75	256,27			166	90	25	
30,00	166	45	25	191,37	236,56	275,85	246,22		166	90	25	
32,00	186	53	32	264,76	308,38	359,59	320,82		186	106	32	
36,00	186	53	32	299,54	350,63	408,87			186	106	32	
40,00	196	63	32	392,53	473,72	552,43			196	125	32	

End mills
Pink

3 FLUTE END MILLS





End mills

Pink

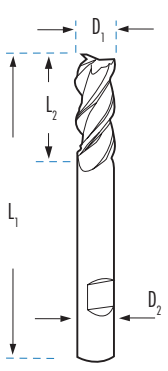
3Z     **INOX** **Al** **TOL D2 h6** 

SHORT SERIES



DIN 844				MATERIAL	FF63	FF75	FT63	FF73	FF76	FT73	FP06	FT03
				COATING	HSSCo 8%	HSSCo 8%	HSSCo 8%	HSSCo 8%	HSSCo 8%	HSSCo 8%	ASP 60	ASP 60
				QUALITY	BRIGHT	TiAlN	TiAlSiN	BRIGHT	TiAlN	TiAlSiN	BRIGHT	TiAlSiN
				ROUGHING	★★	★★★	★★★★	★★	★★★	★★★★		
					TOL k10	TOL k10	TOL k10	 TOL k12	 TOL k12	 TOL k12	TOL e8	TOL e8
D1 mm	L1 mm	L2 mm	D2 mm	€	€	€	€	€	€	€	€	€
1,00	49	3	6								26,66	33,20
2,00	51	7	6	15,69	24,70	28,80					21,66	32,43
2,50	52	8	6	15,69	24,70	28,80						
3,00	52	8	6	15,65	24,70	28,80					21,66	32,43
3,50	55	11	6	16,17	25,16	29,49						
4,00	55	11	6	15,68	24,70	28,80					21,66	32,43
4,50	57	13	6	17,27	26,10	30,44						
5,00	57	13	6	15,68	24,81	28,94					21,66	32,43
5,50	57	13	6	21,32	33,96	39,59						
6,00	57	13	6	16,52	27,75	32,35	44,77	54,08	62,16	21,66	32,43	
6,50	66	16	10	29,62	45,42	52,23						
7,00	66	16	10	23,08	33,35	39,05	52,96*	64,55	74,22	29,16	39,52	
7,50	69	19	10	29,84*	45,90*	52,78*						
8,00	69	19	10	20,61	30,78	35,91	45,88	53,45	62,34	29,16	39,52	
8,50	69	19	10	31,45	47,40	54,50						
9,00	69	19	10	25,74	36,92	43,05	54,45*	63,92*				
9,50	72	22	10		49,81*	57,26*						
10,00	72	22	10	22,33	33,42	38,96	46,17	56,82	66,24	30,91	40,88	
11,00	79	22	12	35,46	52,74	60,64	66,62*	76,75*				
12,00	83	26	12	28,04	39,88	46,51	55,55	65,38	76,25	39,87	51,70	
13,00	83	26	12	44,60	61,32	70,51		84,52*				
14,00	83	26	12	38,20	52,31	61,01	63,39	74,58	86,98	51,66	62,96	
15,00	83	26	12	45,82	63,64	73,18	80,23	87,82	96,80			
16,00	92	32	16	41,94	58,38	68,08	76,84	92,66	108,09	60,76	72,48	
17,00	92	32	16	68,64	90,13	103,62						
18,00	92	32	16	52,70	71,28	83,13	84,07	102,01	118,97	74,77	88,65	
19,00	92	31	16	83,94	103,69	119,24						
20,00	104	38	20	60,51	80,34	93,70	102,58	120,00	139,93	88,92	106,13	
22,00	104	38	20	96,46	121,31	139,48				118,70*	151,83*	
25,00	121	45	25	126,03	160,61	184,68	155,38	177,56	207,06	149,01*	171,22*	
28,00	121	45	25	146,40	179,60	206,49						
30,00	121	45	25	180,10	210,93	242,53	193,22	227,98	265,87			
32,00	133	53	32	183,31	227,65	261,75						

3 FLUTE END MILLS

3Z



INOX

Al

**TOL D1
k10**

**TOL D2
h6**

LONG SERIES

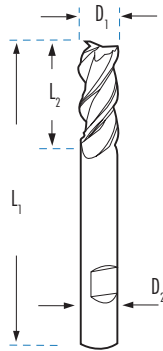





DIN 844/L		MATERIAL		FF83	FF86	FT83
		COATING		HSSCo 8%	HSSCo 8%	HSSCo 8%
		QUALITY		BRIGHT	TiAlN	TiAlSiN
				★★	★★★	★★★★
D1 mm	L1 mm	L2 mm	D2 mm	€	€	€
1,00	52	7	6			
2,00	54	10	6	21,15	30,97	36,11
2,50	56	12	6			
3,00	56	12	6	21,15	30,88	36,00
3,50	59	15	6	23,67	33,10	38,62
4,00	63	19	6	21,15	30,88	36,00
4,50	63	19	6	23,67	33,10	38,62
5,00	68	24	6	21,15	30,88	36,00
5,50	68	24	6	23,67	33,10	38,62
6,00	68	24	6	23,70	32,29	37,66
6,50	68	24	6			
7,00	80	30	10	32,10	43,23	50,42
7,50	80	30	10			
8,00	88	38	10	29,37	39,00	45,48
8,50	88	38	10			
9,00	88	38	10	35,73	46,26	53,96
9,50	88	38	10			
10,00	95	45	10	29,53	42,89	50,01
11,00	102	45	12	45,40*	58,41*	68,11*
12,00	110	53	12	37,56	52,28	60,98
13,00	110	53	12			
14,00	110	53	12	48,93	63,93	74,56
15,00	110	53	12			
16,00	123	63	16	55,13	77,05	89,87
17,00	123	63	16			
18,00	123	63	16	66,81	91,08	106,23
19,00	123	63	16			
20,00	141	75	20	78,43	104,22	121,52
22,00	141	75	20	98,91	134,39	156,72
25,00	166	90	25	144,15	177,54	207,04
28,00	166	90	25	160,48	212,60	247,94
30,00	166	90	25	178,67	227,09	264,83
32,00	186	106	32	212,59	255,77	298,27

MULTI-FLUTE END MILLS

End mills

Pink

4-6 Z   **30° N**  **WELDON**  **34 HRC** **INOX** **Al** **TOL D1 k10** **TOL D2 h6** 

SHORT SERIES

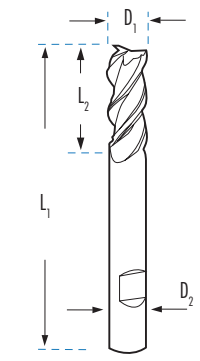

DIN 844					FF18	FF20	FT18	FP07	FT09
MATERIAL					HSSCo 8%	HSSCo 8%	HSSCo 8%	ASP 60	ASP 60
COATING					BRIGHT	TiAlN	TiAlSiN	BRIGHT	TiAlSiN
QUALITY					★★	★★★	★★★★	Premium Quality	Premium Quality
D1 mm	L1 mm	L2 mm	D2 mm	Z	€	€	€	€	€
1,00	49	3	6	4				29,56	35,10
2,00	51	7	6	4	15,75	24,77	28,87	21,60	29,61
2,50	52	8	6	4	15,75	24,77	28,87		
3,00	52	8	6	4	15,75	24,77	28,87	21,60	29,61
3,50	55	11	6	4	16,21	25,23	29,43		
4,00	55	11	6	4	15,75	24,77	28,87	21,60	29,61
4,50	57	13	6	4	17,31	26,16	30,49		
5,00	57	13	6	4	15,75	24,77	28,87	21,60	29,61
5,50	57	13	6	4	25,17	33,96	39,59		
6,00	57	13	6	4	16,43	25,54	29,78	21,60	29,61
6,50	66	16	10	4	25,12	35,35	41,22		
7,00	66	16	10	4	23,08	33,36	38,90	29,36	42,24
7,50	69	16	10	4	29,74	39,71	46,31		
8,00	69	19	10	4	20,31	30,91	36,05	29,23	41,83
8,50	69	19	10	4	31,01	42,00	48,98		
9,00	69	19	10	4	25,63	36,96	43,11	34,54	45,62
9,50	69	19	10	4	32,81	43,69	50,94		
10,00	72	22	10	4	22,21	33,55	39,14	31,04	42,88
11,00	79	22	12	4	30,90	43,66	50,92		
12,00	83	26	12	4	28,04	38,78	45,23	41,00	56,77
13,00	83	26	12	4	39,55	53,94	62,91		
14,00	83	26	12	4	37,33	52,62	61,38	50,94	60,48
15,00	83	26	12	4	42,63	58,81	68,59		
16,00	92	32	16	4	41,60	58,67	68,39	59,71	71,62
17,00	92	32	16	4	51,83	70,24	81,91		
18,00	92	32	16	4	51,24	71,35	83,19	72,82	89,58
19,00	92	31	16	4	60,69	80,75	94,14		
20,00	104	38	20	4	59,99	80,75	94,14	85,64	116,37
22,00	104	38	20	4	83,27	111,91	130,52	112,84	137,25
24,00	121	45	25	5	104,69	131,88	153,80		
25,00	121	45	25	5	100,07	131,26	153,08	145,60	180,98
26,00	121	45	25	5	120,12*	159,34	188,50*		
28,00	121	45	25	5	119,11	159,69	192,61		
30,00	121	45	25	6	138,47	177,25	217,00		
32,00	133	53	32	6	141,97	181,33	222,00		
36,00	133	53	32	6	215,01	260,34	318,69		
40,00	155	63	32	6	258,48*	316,61	387,57*		

LONG SERIES



DIN 844/L				FF21	FF23	FT21	FP20
MATERIAL				HSSCo 8%	HSSCo 8%	HSSCo 8%	ASP 60
COATING				BRIGHT	TiAlN	TiAlSiN	BRIGHT
QUALITY				★★	★★★	★★★★	Premium Quality
L1 mm	L2 mm	D2 mm	Z	€	€	€	€
52	7	6	4				
54	10	6	4	19,22	28,13	32,80	30,69
56	12	6	4	19,12	28,13	32,80	
56	12	6	4	19,22	28,14	32,81	30,69
59	15	6	4	25,26	34,11	39,77	
63	19	6	4	19,22	28,14	32,81	30,69
63	19	6	4	25,26	34,11	39,77	
68	24	6	4	19,22	28,14	32,81	30,69
68	24	6	4	25,10	34,11	39,77	
68	24	6	4	19,22	28,14	32,81	30,69
80	30	10	4	29,16	39,12	45,64	45,78
80	30	10	4				
88	38	10	4	26,49	35,26	41,11	45,78
88	38	10	4				
88	38	10	4	30,18	41,10	47,93	45,78*
88	38	10	4				
95	45	10	4	26,60	38,91	45,39	45,78
102	45	12	4	37,79	51,27	59,81	
110	53	12	4	34,81	48,70	56,82	66,38
110	53	12	4				
110	53	12	4	45,55	59,38	69,25	76,63
110	53	12	4				
123	63	16	4	49,80	69,87	81,48	94,95
123	63	16	4				
123	63	16	4	60,83	83,17	96,99	121,49
123	63	16	4				
141	75	20	4	71,24	96,08	112,03	148,98
141	75	20	5	98,79	126,62	147,67	167,11*
141	75	25	5				
166	90	25	5	130,98	161,71	188,56	242,75
166	90	25	5				
166	90	25	5	146,50	192,37	224,32	
166	90	25	6	165,37	211,32	246,45	
186	106	32	6	166,71	212,82	248,16	
186	106	32	6	238,96	286,89	334,55	
217	125	32	6	264,86	342,06	400,78	

*Available until end of stock

MULTI-FLUTE ROUGHING END MILLS

4-6 Z



SHORT SERIES

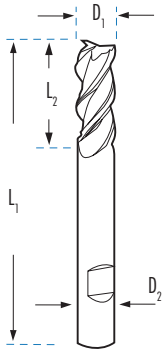

LONG SERIES



DIN 844		MATERIAL			COATING			QUALITY			ROUGHING		
		HSSCo 8%	HSSCo 8%	HSSCo 8%	BRIGHT	TiAlN	TiAlSiN	★★	★★★	★★★★	NR	NR	NR
D1 mm	L1 mm	L2 mm	D2 mm	Z	€	€	€						
6,00	57	13	6	4	40,30	48,65	56,73						
7,00	66	16	10	4	48,43	58,07	67,71						
8,00	69	19	10	4	42,07	51,71	60,30						
9,00	69	19	10	4	50,28	60,88	71,02						
10,00	72	22	10	4	41,74	51,21	59,71						
11,00	79	22	12	4	61,16	73,35	85,55						
12,00	83	26	12	4	50,41	62,43	72,79						
13,00	83	26	12	4	71,57	84,70	98,77						
14,00	83	26	12	4	58,52	72,40	84,44						
15,00	83	26	12	4	76,96	93,19	108,68						
16,00	92	32	16	4	69,42	85,32	99,51						
17,00	92	32	16	4	94,80	112,79	131,52						
18,00	92	32	16	4	75,70	94,01	109,62						
19,00	92	31	16	4	112,03	130,73	152,46						
20,00	104	38	20	4	94,86	114,83	133,91						
NO CENTER CUTTING					FF05	FF74	FT05						
22,00	104	38	20	6	107,17	138,56							
24,00	121	45	25	6	134,99	164,31	183,36						
25,00	121	45	25	6	133,72	163,36	182,30						
26,00	121	45	25	6	154,86	199,90	223,06						
28,00	121	45	25	6	168,93	217,48	242,68						
30,00	121	45	25	6	181,47	238,05	265,63						
32,00	133	53	32	6	205,59	256,03	285,69						
36,00	133	53	32	6	243,66	295,03	329,23						
40,00	155	63	32	6	273,93	341,64	381,24						





DIN 844/L		MATERIAL			COATING			QUALITY			ROUGHING		
		HSSCo 8%	HSSCo 8%	HSSCo 8%	BRIGHT	TiAlN	TiAlSiN	★★	★★★	★★★★	NR	NR	NR
L1 mm	L2 mm	D2 mm	Z	€	€	€							
68	24	6	4	57,12	64,60	75,70							
80	30	10	4	58,88*	73,81*	86,07*							
88	38	10	4	59,07	68,31	79,65							
88	38	10	4	64,77	74,84	87,27							
95	45	10	4	51,45	63,62	74,19							
102	45	12	4	84,20	96,48	112,53							
110	53	12	4	63,55	76,89	89,67							
110	53	12	4										
110	53	12	4	73,43	86,87	101,33							
110	53	12	4										
123	63	16	4	85,96	105,42	122,93							
123	63	16	4										
123	63	16	4	100,39	123,27	143,75							
123	63	16	4										
141	75	20	4	122,18	145,32	169,46							
				FF08	FF58	FT08							
141	75	20	6	137,62	185,63	207,15							
141	75	25	6										
166	90	25	6	173,79	219,91	245,40							
166	90	25	6										
166	90	25	6	195,99	252,82	282,12							
166	90	25	6	254,10	302,00	337,01							
186	106	32	6	265,77	308,74	344,53							
186	106	32	6	319,13	368,69	411,41							
217	125	32	6	377,32	458,90	512,10							

*Available until end of stock

NO CENTER CUTTING MULTI-FLUTE END MILLS

End mills

Pink

4-6 Z  **30° N**  **WELDON**  **34 HRC** **INOX** **Al** **TOL D1 k10** **TOL D2 h6** 

SHORT SERIES

LONG SERIES

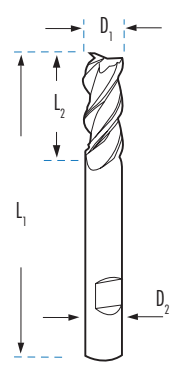



DIN 844					MATERIAL	FF03	FF04	FF54	FT04
					COATING	HSS	HSSCo 8%	HSSCo 8%	HSSCo 8%
					QUALITY	BRIGHT	BRIGHT	TiAIN	TiAISIN
						★	★★	★★★	★★★★
D1 mm	L1 mm	L2 mm	D2 mm	Z	€	€	€	€	
2,00	51	7	6	4	11,28	14,79	23,80	27,77	
2,50	52	8	6	4	11,28	14,79*	23,80*	27,77*	
3,00	52	8	6	4	11,28	14,79	23,80	27,77	
3,50	55	11	6	4	11,64	15,25*	24,34*	28,36*	
4,00	55	11	6	4	11,28	14,79	23,89	27,84	
4,50	57	13	6	4	11,64		24,34		
5,00	57	13	6	4	11,28	14,79	23,89	27,84	
5,50	57	13	6	4	17,53	23,00*	31,99*	37,29*	
6,00	57	13	6	4	11,28	14,79	23,88	27,82	
6,50	66	16	10	4	17,53*	23,00*	33,10*	38,62*	
7,00	66	16	10	4	16,55	21,73	31,90	37,19	
7,50	69	16	10	4	20,74	27,18*	37,08	43,24*	
8,00	69	19	10	4	12,85	16,68	27,04	31,54	
8,50	69	19	10	4	21,61				
9,00	69	19	10	4	17,31	22,68	33,88	39,51	
9,50	72	22	10	4	23,46	29,99*	41,25	48,11*	
10,00	72	22	10	4	15,70	20,58	31,92	37,21	
11,00	79	22	12	4	21,64	28,39	41,17	48,02	
12,00	83	26	12	4	18,67	24,56	37,04	43,19	
13,00	83	26	12	4	27,83	36,65	50,46	58,83	
14,00	83	26	12	4	26,33	34,46	48,54	56,60	
15,00	83	26	12	4	30,01	39,33	55,90	65,18	
16,00	92	32	16	4	29,29	38,36	54,98	64,11	
17,00	92	32	16	4	36,08	47,49	65,74	76,66	
18,00	92	32	16	4	36,04	47,29	65,74	76,66	
19,00	92	31	16	4	42,68	55,64	75,42	87,97	
20,00	104	38	20	4	42,24	55,64	75,42	87,97	
22,00	104	38	20	4	58,65	77,22	104,40	121,75	
24,00	121	45	25	5	72,84	95,96	122,72	143,11	
25,00	121	45	25	5	72,60	95,96	122,72	143,11	
26,00	121	45	25	5	91,06	119,96*	155,14*	180,91*	
28,00	121	45	25	5	91,06	119,96	159,33	185,79	
30,00	121	45	25	6	105,57	138,28	177,66	207,19	
32,00	133	53	32	6	108,58	141,85	181,79	212,00	
36,00	133	53	32	6	142,08	187,13	227,64	265,45	
40,00	143	63	32	6	170,34	224,93	279,34	325,76	

DIN 844/L				MATERIAL	FF07	FF57	FT07
				COATING	HSSCo 8%	HSSCo 8%	HSSCo 8%
				QUALITY	BRIGHT	TiAIN	TiAISIN
					★★	★★★	★★★★
L1 mm	L2 mm	D2 mm	Z	€	€	€	
54	10	6	4	18,49 *	28,62 *	33,53 *	
56	12	6	4	18,49 *	26,27 *	30,78 *	
56	12	6	4	18,49 *	29,76 *	34,88 *	
59	15	6	4	24,33 *	35,72 *	41,86 *	
63	19	6	4	18,49 *	29,76 *	34,88 *	
63	19	6	4	24,33 *	35,72 *	41,86 *	
68	24	6	4	18,49 *	29,76 *	34,88 *	
68	24	6	4	24,33 *	35,72 *	41,86 *	
68	24	6	4	18,49 *	29,76 *	34,88 *	
80	30	10	4	27,99 *	41,08 *	48,13 *	
80	30	10	4				
88	38	10	4	25,69 *	38,71 *	45,33 *	
88	38	10	4				
88	38	10	4	29,06 *	43,32 *	50,76 *	
88	38	10	4				
95	45	10	4	25,55 *	41,19 *	48,28 *	
102	45	12	4	34,95 *	51,98 *	60,92 *	
110	53	12	4	32,46 *	49,44 *	57,93 *	
110	53	12	4				
110	53	12	4	42,43 *	59,98 *	70,28 *	
110	53	12	4				
110	53	12	4				
123	63	16	4	46,37 *	70,91 *	83,09 *	
123	63	16	4				
123	63	16	4	56,64 *	84,26 *	98,72 *	
123	63	16	4				
141	75	20	4	66,33 *	96,69 *	113,29 *	
141	75	20	5	91,99 *	127,09	148,92	
141	75	25	5				
166	90	25	5	122,01 *	162,72 *	190,65 *	
166	90	25	5				
166	90	25	5	149,13 *	200,38 *	234,79 *	
166	90	25	6	170,68 *	222,15 *	260,27 *	
186	106	32	6	170,41 *	223,71 *	262,11 *	
186	106	32	6	243,05 *	307,38 *	360,16 *	
217	125	32	6	270,17 *	413,11 *	484,05 *	

*Available until end of stock

MULTI-FLUTE ROUGHING END MILLS

3-5 Z   **30° N**  **WELDON**  **34 HRC** **INOX** **Al** **TOL D1 k12** **TOL D2 h6**

SHORT SERIES

LONG SERIES

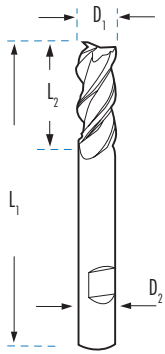

DIN 844		MATERIAL				ASP 60	ASP 60	ASP 60	ASP 60
		COATING				BRIGHT	TiAlSiN	BRIGHT	TiAlSiN
		ROUGHING				NF	NF	NR	NR
		QUALITY				Premium Quality	Premium Quality	Premium Quality	Premium Quality
D1 mm	L1 mm	L2 mm	D2 mm	Z	€	€	€	€	
2,00	51	7	6	3					
2,50	52	8	6	3					
3,00	52	8	6	3					
3,50	55	11	6	3					
4,00	55	11	6	3					
4,50	57	13	6	3					
5,00	57	13	6	3					
5,50	57	13	6	3					
6,00	57	13	6	3	50,47	57,92	46,77	53,78	
6,50	66	16	10	3					
7,00	66	16	10	3	64,72	70,47	58,72*	66,82*	
7,50	69	19	10	3					
8,00	69	19	10	3	55,74	64,93	51,11	59,04	
8,50	69	19	10	3					
9,00	69	19	10	3	67,14	73,52	61,08*	69,88*	
9,50	72	22	10	3					
10,00	72	22	10	4	53,15	63,00	48,18	59,83	
11,00	79	22	12	4					
12,00	83	26	12	4	69,92	79,19	63,75	72,95	
13,00	83	26	12	4					
14,00	83	26	12	4	84,91	96,53	76,98	87,54	
15,00	83	26	12	4					
16,00	92	32	16	4	104,08	114,76	94,90	106,92	
17,00	92	32	16	4					
18,00	92	32	16	4	114,28	124,79	102,97	116,95	
19,00	92	31	16	4					
20,00	104	38	20	4	141,76	156,28	128,14	146,61	
22,00	104	38	20	5	174,76	192,54	158,48	180,11	
24,00	121	45	25	5					
25,00	121	45	25	5	207,16	230,18	187,91	213,19	
26,00	121	45	25	5					
28,00	121	45	25	5					
30,00	121	45	25	5					
32,00	133	53	32	5					
36,00	133	53	32	5					
40,00	155	63	32	5					

DIN 844/L		MATERIAL				ASP 60	ASP 60	ASP 60	ASP 60
		COATING				BRIGHT	TiAlSiN	BRIGHT	TiAlSiN
		ROUGHING				NF	NF	NR	NR
		QUALITY				Premium Quality	Premium Quality	Premium Quality	Premium Quality
L1 mm	L2 mm	D2 mm	Z	€	€	€	€		
54	10	6	3						
56	12	6	3						
56	12	6	3						
59	15	6	3						
63	19	6	3						
63	19	6	3						
68	24	6	3						
68	24	6	3						
68	24	6	3	79,20	83,67	70,25	77,31		
68	24	6	3						
80	30	10	3	89,53	101,93	81,31	94,95		
80	30	10	3						
88	38	10	3	83,30	88,66	73,74	82,59*		
88	38	10	3						
88	38	10	3	87,87*	100,56	81,31	95,56		
88	38	10	3						
95	45	10	4	74,95	83,36	66,79	76,97		
102	45	12	4						
110	53	12	4	94,98	103,76	83,89	94,98		
110	53	12	4						
110	53	12	4	111,33	127,74	100,12	113,06		
110	53	12	4						
123	63	16	4	133,17	146,28	118,82	134,97		
123	63	16	4						
123	63	16	4	148,96	173,45	135,71*	154,63*		
123	63	16	4						
141	75	20	4	193,63	212,40	171,55	197,49		
141	75	20	5	295,83	316,13	259,04	286,78		
141	75	25	5						
166	90	25	5	297,06	326,15	262,04	303,94		
166	90	25	5						
166	90	25	5						
166	90	25	5						
186	106	32	5						
186	106	32	5						
217	125	32	5						

End mills

Pink

3 FLUTE END MILLS SHORT SERIES

3Z



INOX

Al

TOL D1
e8TOL D2
h6

SUPER-SHORT SERIES

EXTRA-SHORT SERIES

D1 mm	L1 mm	L2 mm	D2 mm	Z	FF51	€
					HSSCo 8% BRIGHT	
1,00	34	2	6	3		15,06
1,50	34	3	6	3		15,06
2,00	35	4	6	3		15,03
2,50	36	5	6	3		15,03
3,00	36	5	6	3		15,03
3,50	37	6	6	3		15,03
4,00	38	7	6	3		15,03
4,50	38	7	6	3		15,03
5,00	39	8	6	3		15,03
5,50	39	8	6	3		15,03
6,00	39	8	6	3		15,03
6,50	42	10	8	3		20,66
7,00	42	10	8	3		20,66
7,50	42	10	8	3		20,66
8,00	43	11	8	3		20,66
8,50	48	11	10	3		23,68
9,00	48	11	10	3		23,68
9,50	48	11	10	3		23,68
10,00	50	13	10	3		23,68



D1 mm	L1 mm	L2 mm	D2 mm	Z	FF53	€
					HSSCo 8% BRIGHT	
2,00	38	7	6	3		16,48
2,50	39	8	6	3		16,48
3,00	39	8	6	3		16,48
3,50	41	10	6	3		16,48
4,00	42	11	6	3		16,48
4,50	42	11	6	3		16,48
5,00	44	13	6	3		16,48
5,50	44	13	6	3		16,48
6,00	44	13	6	3		16,48
6,50	48	16	8	3		22,68
7,00	48	16	8	3		22,68
8,00	51	19	8	3		22,68
8,50	56	19	10	3		25,94
9,00	56	19	10	3		25,94
10,00	59	22	10	3		25,94



SOLID CARBIDE ROUTERS FOR COMPOSITE AND FIBER GLASS MATERIALS, PHENOLIC BOARDS, ETC

SOLID CARBIDE



PHENOLIC

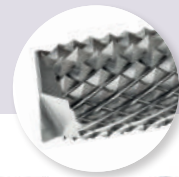
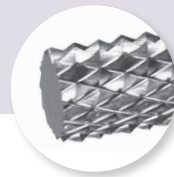
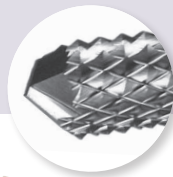

REV. AND FEED		
D ₁ mm	RPM rev./min	FEED mm/min
1.50	60.000	3.000
2.00	50.000	2.500
3.00	32.000	1.600
5.00	20.000	1.200
6.00	16.000	1.000
6.35	14.000	1.000
8.00	9.000	700
10.00	7.000	550
12.00	6.000	450

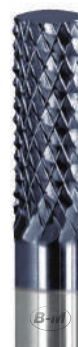
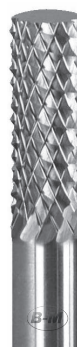

D ₁ mm	L ₁ mm	L ₂ mm	D ₂ mm		RFC		RFCTL		RF		RFTL		RFF		RFFTL	
					€	TiAlN	€		€	TiAlN	€		€	TiAlN	€	
1,50	38	5	3,00	RFC0150	19,38	RFC0150TL	29,29	RF0150	18,37	RF0150TL	28,28	RFF0150		RFF0150TL		
2,00	38	10	3,00	RFC0200	19,38	RFC0200TL	29,29	RF0200	18,37	RF0200TL	28,28	RFF0200		RFF0200TL		
3,00	38	12	3,00	RFC0300	19,38	RFC0300TL	29,29	RF0300	18,37	RF0300TL	28,28	RFF0300	19,38	RFF0300TL	29,29	
5,00	50	16	5,00	RFC0500	38,46	RFC0500TL	48,39	RF0500	34,93	RF0500TL	44,84	RFF0500	38,46	RFF0500TL	48,39	
6,00	63	25	6,00	RFC0600	45,74	RFC0600TL	57,79	RF0600	41,46	RF0600TL	53,54	RFF0600	45,74	RFF0600TL	57,79	
6,35	75	30	6,35	RFC0635	50,78	RFC0635TL	62,88	RF0635	46,49	RF0635TL	58,56	RFF0635	50,78	RFF0635TL	62,88	
8,00	63	25	8,00	RFC0800	76,15	RFC0800TL	87,56	RF0800	69,13	RF0800TL	80,51	RFF0800	76,15	RFF0800TL	87,56	
10,00	63	25	10,00	RFC1000	96,74	RFC1000TL	108,71	RF1000	87,97	RF1000TL	99,93	RFF1000	96,74	RFF1000TL	108,71	
12,00	75	25	12,00	RFC1200	121,62	RFC1200TL	136,45	RF1200	110,60	RF1200TL	125,40	RFF1200	121,62	RFF1200TL	136,45	

NEW SOLID CARBIDE

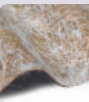

PHENOLIC

• Multi-cut geometry adapted to the machining of composite materials, in order to avoid delamination of carbon fiber and fiberglass. Valid for the transformation of Phenolic Panel.

REV. AND FEED		
D ₁ mm	RPM rev./min	FEED mm/min
3,00	15.000	2.250
4,00	12.000	1.800
5,00	10.000	1.800
6,00	8.500	1.700
8,00	6.500	1.950
10,00	5.500	1.650
12,00	4.500	1.550



D ₁ mm	L ₁ mm	L ₂ mm	D ₂ mm	FC11		FC12		FC13		FC14	
				Right	€	Straight	€	Left	€	Ball	€
3,00	45	10	3,00	FC1133	34,95	FC1233	34,95	FC1333	34,95	FC1433	36,47
3,00	60	10	6,00	FC1136	39,89	FC1236	39,89	FC1336	39,89	FC1436	39,89
4,00	60	15	4,00	FC1144	45,59	FC1244	45,59	FC1344	45,59	FC1444	49,01
4,00	60	15	6,00	FC1146	72,18	FC1246	72,18	FC1346	45,59	FC1446	73,70
5,00	60	15	5,00	FC1155	61,16	FC1255	61,16	FC1355	61,16	FC1455	61,16
6,00	70	25	6,00	FC1166	74,46	FC1266	74,46	FC1366	74,46	FC1466	70,28
8,00	80	30	8,00	FC1188	113,97	FC1288	113,97	FC1388	113,97	FC1488	122,32
10,00	80	35	10,00	FC11010	170,95	FC121010	170,95	FC131010	170,95	FC141010	170,95
12,00	90	40	12,00	FC11212	227,55	FC121212	227,55	FC131212	227,55	FC141212	235,53

HSSCo SINGLE FLUTE END MILLS (FOR ALUMINIUM & PVC)

End mills

Pink

HSSCo
Al
PVC
TOL D1 k12
TOL D2 h6

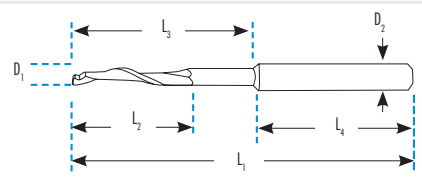

SHORT SERIES



LONG SERIES



FF13

	D1 mm	L1 mm	L2 mm	D2 mm	HSSCo €	TiN €
FF1381	1,0	60	10	8	46,49	65,48
FF1382	2,0	60	10	8	46,49	65,48
FF1383	3,0	60	10	8	17,71	25,84
FF1384	4,0	60	12	8	17,71	25,84
FF1385	5,0	60	13	8	17,71	25,84
FF1386	6,0	60	14	8	18,69	26,78
FF1387	7,0	60	14	8	21,61	30,39
FF1388	8,0	80	14	8	21,61	30,39
FF131010	10,0	80	15	10	23,97	31,49
FF131212	12,0	80	35	12	58,70	73,37
FF131414	14,0	100	40	12	70,79	88,49
FF131616	16,0	100	40	16	75,61	94,51
FF132020	20,0	100	40	20	85,71	107,14
FF1361	1,0	45	6	6	32,45	43,02
FF13615	1,5	45	6	6	32,45	43,02
FF1362	2,0	45	6	6	32,45	43,02
FF1363	3,0	60	12	6	16,81	23,57
FF1364	4,0	60	12	6	16,86	23,57
FF1365	5,0	60	12	6	16,86	23,57
FF1366	6,0	60	14	6	16,86	23,57

FF14

	D1 mm	L1 mm	L2 mm	L3 mm	D2 mm	HSSCo €	TiN €
FF1483	3	80	16	45	8	30,48	38,69
FF1484	4	80	16	45	8	26,20	34,35
FF1485	5	80	16	45	8	26,20	34,35
FF1486	6	90	16	45	8	26,20	34,35
FF1487	7	90	20	50	8	33,60	42,36
FF1488	8	100	30	70	8	30,38	39,05
FF1465	5	80	14	45	6	25,93	34,35
FF1466	6	80	14	45	6	25,95	34,35

EXTRA LONG SERIES



FF14-E

	D1 mm	L1 mm	L2 mm	L3 mm	D2 mm	L4 mm	HSSCo €	TiN €
FF1485-E	5	100	30	55	8	45	25,41	31,81
FF1485-EL	5	100	50	-	8	50	30,42	43,20

DRILLING IN METAL PROFILES

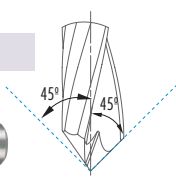

LACQUERED ALUMINIUM



FF50

	D1 mm	L1 mm	L2 mm	L3 mm	D2 mm	HSSCo €	TiN €
FF5084	4	80	16	35	8	23,57	32,16
FF5085	5	80	18	35	8	23,57	32,16

FF14

	D1 mm	L1 mm	L3 mm	D2 mm	HSSCo €	TiN €
FF14848040	4	80	40	8	61,22	70,40
FF148411040	4	110	40	8	81,49	93,72
FF14858040	5	80	40	8	59,92	68,91
FF148511040	5	110	40	8	83,18	95,66
FF14868040	6	80	40	8	50,29	57,84
FF148611040	6	110	40	8	83,18	95,66

SPECIAL SIZES



FF14 Specials

	D1 mm	L1 mm	L2 mm	L3 mm	D2 mm	HSSCo €
FF148412020	4	120	20	-	8	28,42
FF14856018	5	60	18	-	8	23,43
FF14859025	5	90	25	-	8	30,57
FF148510025	5	100	25	-	8	28,41
FF148512014	5	120	14	-	8	28,41
FF14851001817	5	100	18	35	8	28,87
FF14851201461	5	120	14	75	8	38,87
FF14851201817	5	120	18	35	8	38,87
FF1486801421	6	80	14	35	8	32,20
FF14861001835	6	100	18	35	8	32,20
FF14861201461	6	120	14	75	8	46,58

FF14 Specials

	D1 mm	L1 mm	L2 mm	L3 mm	D2 mm	HSSCo €
FF14861003045	6	100	30	45	8	39,07
FF14861006040	6	100	60	-	8	50,15
FF14888025	8	80	25	-	8	25,37
FF148810014	8	100	14	-	8	28,06
FF148812014	8	120	14	-	8	30,46
FF14881201476	8	120	14	90	8	36,76
FF14898014	9	80	14	-	8	29,42
FF148108014	10	80	14	-	8	31,32
FF1410101003040	10	100	30	70	10	38,23
FF1410101201481	10	120	14	95	10	40,72
FF14101012014	10	120	14	-	10	32,82
FF148128014	12	80	14	-	8	35,52

SOLID CARBIDE SINGLE FLUTE END MILLS (FOR ALUMINIUM & PVC)

SOLID CARBIDE **Al** **PVC** **TOL h10** **TOL D2 h6**

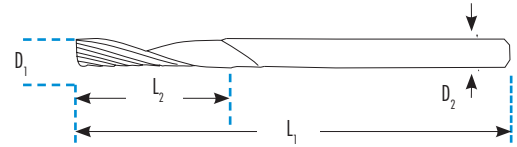

HELIX A - SHORT SERIES



HELIX A - LONG SERIES



Helix A	D1 mm	L1 mm	L2 mm	D2 mm	FMGA13	
					CARBIDE	
					€	
FMGA13305	0,5	39	1,5	3	54,01	
FMGA1331	1,0	39	3,0	3	41,40	
FMGA13315	1,5	39	4,0	3	37,26	
FMGA1322	2,0	40	10,0	2	31,40	
FMGA13325	2,5	40	12,0	3	31,40	
FMGA1333	3,0	40	12,0	3	26,59	
FMGA1336	3,0	64	12,0	6	46,52	
FMGA1338	3,0	64	12,0	8	67,38	
FMGA1344	4,0	50	16,0	4	29,23	
FMGA1346	4,0	64	16,0	6	46,99	
FMGA1348	4,0	64	16,0	8	78,41	
FMGA135550	5,0	50	16,0	5	30,34	
FMGA1355	5,0	64	16,0	5	33,24	
FMGA1356	5,0	64	16,0	6	52,89	
FMGA1358	5,0	64	16,0	8	80,18	
FMGA136650	6,0	50	16,0	6	40,79	
FMGA1366	6,0	64	20,0	6	44,94	
FMGA1368	6,0	64	20,0	8	81,40	
FMGA1378	7,0	64	20,0	8	91,26	
FMGA138816	8,0	66	16,0	8	46,27	
FMGA1388	8,0	76	38,0	8	61,36	
FMGA13101015	10,0	76	15,0	10	72,36	
FMGA131010	10,0	76	30,0	10	76,90	

Helix A	D1 mm	L1 mm	L2 mm	D2 mm	FMGA13E	
					CARBIDE	
					€	
FMGA133312E	3	70	12	3	30,75	
FMGA133322E	3	70	22	3	32,05	
FMGA133332E	3	70	32	3	34,11	
FMGA134415E	4	70	15	4	39,99	
FMGA134425E	4	70	25	4	42,36	
FMGA134435E	4	70	35	4	45,25	
FMGA135517E	5	80	17	5	52,36	
FMGA1355E	5	80	38	5	58,59	
FMGA136620E	6	85	20	6	58,36	
FMGA1366E	6	85	40	6	64,71	
FMGA138825E	8	90	25	8	78,36	
FMGA1388E	8	90	38	8	83,18	
FMGA1388EX	8	110	43	8	109,13	
FMGA131010E	10	100	40	10	119,26	
FMGA131010EL	10	120	60	10	154,59	

HELIX A - WITH NECK



CUTTING SPEED FOR SINGLE FLUTE END MILLS

D1 mm	HSSCo		CARBIDE	
	Aluminium (R.P.M.)	PVC (R.P.M.)	Aluminium (R.P.M.)	PVC (R.P.M.)
	3,00	12000	12000	19000
4,00	11000	11000	18000	18000
5,00	10000	10000	18000	18000
6,00	10000	10000	17000	17000
7,00	9000	9000	17000	17000
8,00	9000	9000	16000	16000
9,00	9000	9000	16000	16000
10,00	9000	9000	16000	16000

Helix A	D1 mm	L1 mm	L2 mm	D2 mm	FMGA13	
					CARBIDE	
					€	
FMGA13488016	4	8	80	16	29	69,95
FMGA13588016	5	8	80	16	29	69,95
FMGA13689016	6	8	90	16	29	69,95

End mills

Pink

End mills

Pink

SOLID CARBIDE SINGLE FLUTE END MILLS (FOR ALUMINIUM & PVC)

SOLID CARBIDE **Al** **PVC** **TOL h10** **TOL D2 h6**

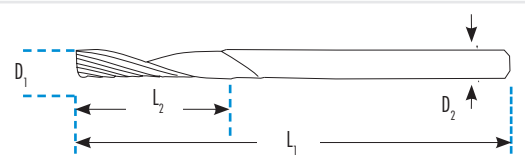

HELIX B 

FMGA13HI					
	D1 mm	L1 mm	L2 mm	D2 mm	CARBIDE €
FMGA1333HI	3	50	8	3	34,64
FMGA1344HI	4	64	12	4	34,64
FMGA1355HI	5	64	16	5	37,51
FMGA1366HI	6	64	20	6	56,63
FMGA1388HI	8	76	38	8	74,94
FMGA131010HI	10	76	35	10	91,60

HELIX C 

FMGA13CO					
	D1 mm	L1 mm	L2 mm	D2 mm	CARBIDE €
FMGA1366CO	6	64	25	6	137,28
FMGA1388CO	8	64	25	8	189,83
FMGA131010CO	10	76	35	10	223,12
FMGA131212CO	12	76	35	12	296,00

STRAIGHT FLUTE 

FMGA13R					
	D1 mm	L1 mm	L2 mm	D2 mm	CARBIDE €
FMGA1346R	4	64	16	6	50,76
FMGA1356R	5	64	20	6	50,76
FMGA1366R	6	64	25	6	59,10
FMGA1388R	8	64	25	8	87,42
FMGA131010R	10	88	35	10	114,42
FMGA131212R	12	88	35	12	165,14

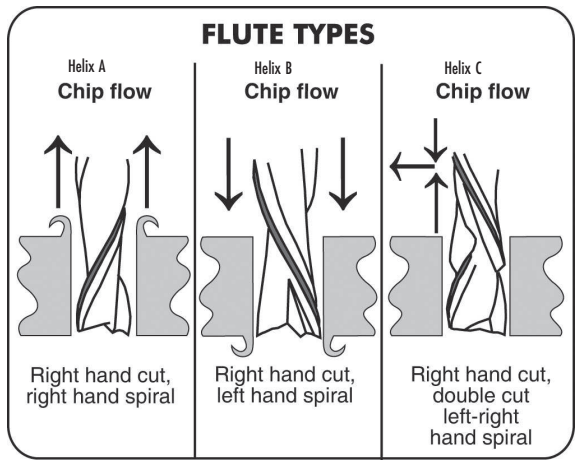

SOLID CARBIDE TYRE BURRS

SOLID CARBIDE



RN					
	D1 mm	L1 mm	L2 mm	D2 mm	€
RN0300	3,00	50	25	3	18,86
RN0600	6,00	80	50	6	45,51
RN0800	8,00	110	50	8	51,25
RN1000	10,00	110	60	10	80,43

SOLID CARBIDE ROUTERS, ROTOZIP TYPE ACCESSORIES

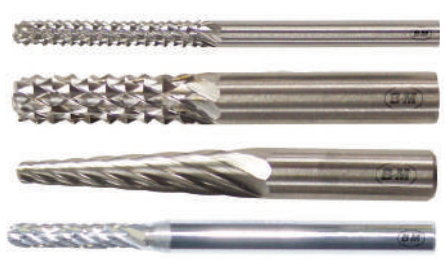

RR						
		D1 mm	L1 mm	L2 mm	D2 mm	€
RR0317	Tile	3,17	50	25	3,17	21,75*
RR0635	Tile	6,35	50	25	6,35	36,45*
RR0435	Drywall	6,35	52	32	6,35	45,61*
RR0247	Grout	2,47	38	14	3,17	15,98*

*Available until end of stock

T SLOT CUTTERS

Ref. FF17

"T" SLOTS CUTTERS

DIN 851A

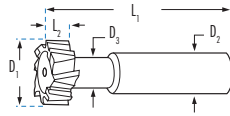

TOL D1
d11

TOL D2
h6

FF17						
D1 x L2 mm	D2 mm	D3 mm	Z	L1 mm	HSSCo €	TiAlN €
11,0x4,0	10	4	4	53,5	106,12	130,40
12,5x6,0	10	5	6	57,0	110,31	137,91
16,0x8,0	10	7	6	62,0	121,30	153,89
18,0x8,0	12	8	8	70,0	127,77	164,54
21,0x9,0	12	10	8	74,0	140,72	197,66
25,0x11,0	16	12	8	82,0	158,82	215,25
32,0x14,0	16	15	10	90,0	200,34	279,15
40,0x18,0	25	19	10	108,0	277,89	389,15
50,0x22,0	32	25	10	124,0	334,15	438,22
60,0x28,0	32	30	10	139,0	349,30	458,13
72,0x35,0	32	35	10	153,0	364,49	478,05

Ref. FF17C

"T" SLOTS CUTTERS

DIN 851B

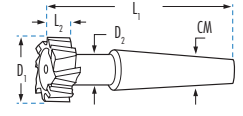

TOL D2
h12

FF17C						
D1 x L2 mm	MT*	THREAD	D2 mm	L1 mm	HSSCo €	TiAlN €
18,0x8,0	1	M6	8	70	139,21	172,62
21,0x9,0	2	M10	10	74	152,85	189,53
25,0x11,0	2	M10	12	82	159,35	197,60
32,0x14,0	2	M10	16	90	212,52	263,53
40,0x18,0	3	M12	20	108	268,68	333,16
50,0x22,0	4	M16	25	124	354,87	440,02
60,0x28,0	4	M16	31	139	469,53	582,21
72,0x35,0	5	M20	36	153	637,31	790,25

MT*: Morse taper shank

CORNER RADIUS END MILLS

4 Z

HSSCo 8%

DIN 6518N

WELDON

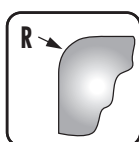
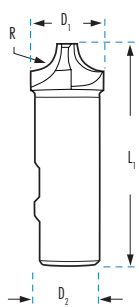

FF1/4R					
	TOL H11	js 15	TOL h6	L1	€
	R	D1 mm	D2 mm	mm	
FF1/4R1	1,0	8	10	60	74,32
FF1/4R1.50	1,5	9	10	60	71,88
FF1/4R2	2,0	10	10	60	60,48
FF1/4R2.50	2,5	11	10	60	69,58
FF1/4R3	3,0	12	12	60	69,32
FF1/4R3.50	3,5	13	12	60	90,28
FF1/4R4	4,0	14	12	60	76,98
FF1/4R4.50	4,5	15	12	60	102,90
FF1/4R5	5,0	16	12	60	86,26
FF1/4R5.50	5,5	19	16	67	102,90
FF1/4R6	6,0	20	16	67	86,41
FF1/4R6.50	6,5	21	16	71	130,97
FF1/4R7	7,0	22	16	71	118,09
FF1/4R7.50	7,5	23	16	71	142,56
FF1/4R8	8,0	24	16	71	118,09
FF1/4R8.50	8,5	25	25	85	174,63
FF1/4R9	9,0	26	25	85	153,91
FF1/4R9.50	9,5	27	25	85	183,53
FF1/4R10	10,0	28	25	85	153,91
FF1/4R10.50	10,5	31	25	90	213,82
FF1/4R11	11,0	32	25	90	205,48
FF1/4R12	12,0	34	25	90	169,30
FF1/4R12.50	12,5	41	25	100	219,87
FF1/4R13	13,0	42	25	100	272,54
FF1/4R14	14,0	44	25	100	282,80
FF1/4R15	15,0	46	25	100	352,06
FF1/4R16	16,0	48	25	100	323,59
FF1/4R18	18,0	52	32	112	417,39
FF1/4R20	20,0	56	32	112	468,92

WOODRUFF KEYSEAT CUTTERS

Ref. FF16

WOODRUFF TYPE

DIN 850B

TOL D1 h12

TOL D2 h6

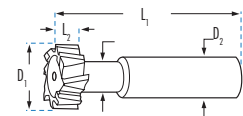

FF16					
D1 x L2 mm	D2 mm	Z	L1 mm	HSSCo €	TiAlN €
4,5x1,0	6	6	50	60,33	71,35
7,5x1,5	6	6	50	62,82	75,50
7,5x2,0	6	6	50	62,82	75,50
10,5x2,0	6	6	50	67,58	81,47
10,5x2,5	6	6	50	67,58	81,47
10,5x3,0	6	6	50	67,58	81,47
13,5x3,0	10	6	56	68,65	85,76
13,5x4,0	10	6	56	68,65	85,76
16,5x3,0	10	6	56	69,27	91,83
16,5x4,0	10	6	56	69,27	91,83
16,5x5,0	10	6	56	69,27	88,84
19,5x4,0	10	8	63	78,86	104,18
19,5x5,0	10	8	63	78,86	99,82
19,5x6,0	10	8	63	78,86	99,82
22,5x5,0	10	8	63	86,38	115,71
22,5x6,0	10	8	63	86,38	116,28
22,5x8,0	10	8	63	86,38	116,28
25,5x6,0	10	10	63	101,16	144,01
28,5x6,0	10	10	63	102,91	145,74
28,5x8,0	10	10	63	102,91	145,74
28,5x10,0	12	10	71	102,91	145,74
32,5x7,0	12	10	71	127,62	174,41
32,5x8,0	12	10	71	127,62	174,41
32,5x10,0	12	10	71	127,62	174,41
45,5x10,0	12	12	71	201,88	287,01

DOVETAIL AND INVERTED DOVETAIL MILLING CUTTERS



Ref. FF98
Ref. FF99

HSSCo

DIN
1833ATOL D₁
js16TOL D₂
h6

Ref. FF97
Ref. FF95

HSSCo

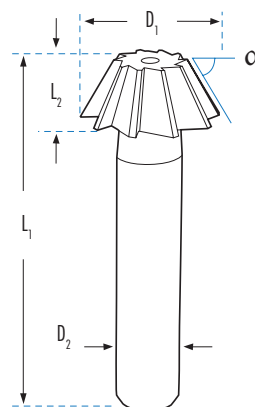
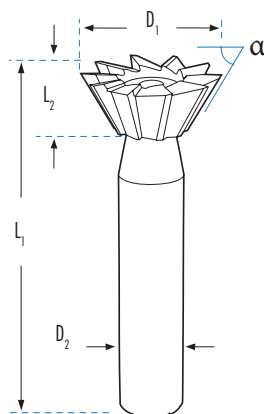
DIN
1833BTOL D₁
js16TOL D₂
h6

FF98

45°	D ₁ mm	α	D ₂ mm	L ₁ mm	L ₂ mm	Z	€
FF981600	16	45°	12	60	4,0	8	107,32
FF982000	20	45°	12	63	5,0	10	113,79
FF982500	25	45°	12	67	6,3	12	139,13
FF983200	32	45°	16	71	8,0	14	155,25

FF97

45°	D ₁ mm	α	D ₂ mm	L ₁ mm	L ₂ mm	Z	€
FF971600	16	45°	12	60	4,0	8	86,40
FF972000	20	45°	12	63	5,0	10	97,16
FF972500	25	45°	12	67	6,3	12	109,25
FF973200	32	45°	16	71	8,0	12	124,24

FF99

60°	D ₁ mm	α	D ₂ mm	L ₁ mm	L ₂ mm	Z	€
FF991600	16	60°	12	60	6,3	8	107,28
FF992000	20	60°	12	63	8,0	10	113,74
FF992500	25	60°	12	67	10,0	12	139,11
FF993200	32	60°	16	71	12,5	14	155,22

FF95

60°	D ₁ mm	α	D ₂ mm	L ₁ mm	L ₂ mm	Z	€
FF951600	16	60°	12	60	6,3	8	84,76
FF952000	20	60°	12	63	8,0	10	95,33
FF952500	25	60°	12	67	10,0	12	107,21
FF953200	32	60°	16	71	12,5	12	121,92

SPECIAL SIZES

FF99





FF991600-50	16	50°	12	60	5,0	8	120,47
FF992000-50	20	50°	12	63	6,3	10	128,42
FF992500-50	25	50°	12	67	8,0	12	158,67
FF991600-55	16	55°	12	60	5,6	8	120,47
FF992000-55	20	55°	12	63	7,1	10	128,42
FF992500-55	25	55°	12	67	9,0	12	158,67
FF991600-75	16	75°	12	60	8,0	8	120,47
FF992500-75	25	75°	12	67	10,0	12	158,67
FF991600-80	16	80°	12	60	8,0	8	120,47
FF992500-80	25	80°	12	67	10,0	12	158,67
FF991600-85	16	85°	12	60	8,0	8	120,47
FF992500-85	25	85°	12	67	10,0	12	158,67

SPECIAL SIZES

FF95

FF951600-50	16	50°	12	60	5,0	8	100,58
FF952000-50	20	50°	12	63	6,3	10	128,40
FF952500-50	25	50°	12	67	8,0	12	160,19
FF951600-55	16	55°	12	60	5,6	8	100,58
FF952000-55	20	55°	12	63	7,1	10	128,40
FF952500-55	25	55°	12	67	9,0	12	160,19
FF951600-75	16	75°	12	60	8,0	8	100,58
FF952500-75	25	75°	12	67	10,0	12	160,19

TAPER SHANK END MILLS

4-8 Z      2 Z 

SHORT SERIES

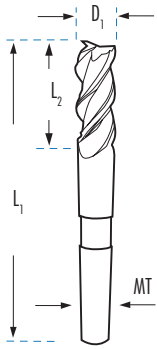

DIN 845B		MATERIAL		COATING		QUALITY		ROUGHING		FF09		FF35		FF39		FF10		FF46		FF48		DIN 326		FF55																					
D1 mm	L1 mm	L2 mm	Z	MT*	THREAD	HSSCo 8%	BRIGHT	QUALITY	ROUGHING	TOL k10	€	HSSCo 8%	TIN	QUALITY	ROUGHING	TOL k10	€	HSSCo 8%	TiAlN	QUALITY	ROUGHING	TOL k12	€	HSSCo 8%	TiAlN	QUALITY	ROUGHING	TOL k12	€	L1 mm	L2 mm	Z	€												
10,00	92	22	4	1	M6	HSSCo 8%	BRIGHT	★★	NR	TOL k10	56,26	HSSCo 8%	TIN	★★★	NR	TOL k10	78,12	HSSCo 8%	TiAlN	★★★	NR	TOL k10	80,45	HSSCo 8%	BRIGHT	★★	NR	TOL k12	83,46	HSSCo 8%	TIN	★★★	NR	TOL k12	104,26	HSSCo 8%	TiAlN	★★★	NR	TOL k12	107,30	83	13	2	70,74
12,00	111	26	4	2	M6	HSSCo 8%	BRIGHT	★★	NR	TOL k10	74,38	HSSCo 8%	TIN	★★★	NR	TOL k10	95,42	HSSCo 8%	TiAlN	★★★	NR	TOL k10	100,02	HSSCo 8%	BRIGHT	★★	NR	TOL k12	85,06	HSSCo 8%	TIN	★★★	NR	TOL k12	106,46	HSSCo 8%	TiAlN	★★★	NR	TOL k12	110,58	86	16	2	73,44
14,00	111	26	4	2	M10	HSSCo 8%	BRIGHT	★★	NR	TOL k10	82,41	HSSCo 8%	TIN	★★★	NR	TOL k10	104,49	HSSCo 8%	TiAlN	★★★	NR	TOL k10	110,53	HSSCo 8%	BRIGHT	★★	NR	TOL k12	96,64	HSSCo 8%	TIN	★★★	NR	TOL k12	118,96	HSSCo 8%	TiAlN	★★★	NR	TOL k12	124,74	101	16	2	76,20
15,00	111	26	4	2	M10	HSSCo 8%	BRIGHT	★★	NR	TOL k10	88,43	HSSCo 8%	TIN	★★★	NR	TOL k10	114,37	HSSCo 8%	TiAlN	★★★	NR	TOL k10	119,88	HSSCo 8%	BRIGHT	★★	NR	TOL k12	120,72	HSSCo 8%	TIN	★★★	NR	TOL k12	145,44	HSSCo 8%	TiAlN	★★★	NR	TOL k12	152,52				
16,00	117	32	4	2	M10	HSSCo 8%	BRIGHT	★★	NR	TOL k10	82,05	HSSCo 8%	TIN	★★★	NR	TOL k10	108,46	HSSCo 8%	TiAlN	★★★	NR	TOL k10	113,68	HSSCo 8%	BRIGHT	★★	NR	TOL k12	99,67	HSSCo 8%	TIN	★★★	NR	TOL k12	126,08	HSSCo 8%	TiAlN	★★★	NR	TOL k12	130,96	104	19	2	83,26
18,00	117	32	4	2	M10	HSSCo 8%	BRIGHT	★★	NR	TOL k10	87,15	HSSCo 8%	TIN	★★★	NR	TOL k10	113,20	HSSCo 8%	TiAlN	★★★	NR	TOL k10	118,64	HSSCo 8%	BRIGHT	★★	NR	TOL k12	109,39	HSSCo 8%	TIN	★★★	NR	TOL k12	135,01	HSSCo 8%	TiAlN	★★★	NR	TOL k12	141,60	104	19	2	87,28
20,00	123	38	4	2	M10	HSSCo 8%	BRIGHT	★★	NR	TOL k10	97,22	HSSCo 8%	TIN	★★★	NR	TOL k10	127,47	HSSCo 8%	TiAlN	★★★	NR	TOL k10	133,62	HSSCo 8%	BRIGHT	★★	NR	TOL k12	120,31	HSSCo 8%	TIN	★★★	NR	TOL k12	150,13	HSSCo 8%	TiAlN	★★★	NR	TOL k12	157,45	107	22	2	91,59
22,00	123	38	5	2	M10	HSSCo 8%	BRIGHT	★★	NR	TOL k10	109,95	HSSCo 8%	TIN	★★★	NR	TOL k10	138,68	HSSCo 8%	TiAlN	★★★	NR	TOL k10	146,70	HSSCo 8%	BRIGHT	★★	NR	TOL k12	132,44	HSSCo 8%	TIN	★★★	NR	TOL k12	161,34	HSSCo 8%	TiAlN	★★★	NR	TOL k12	169,17	107	22	2	107,87
24,00	147	45	6	3	M12	HSSCo 8%	BRIGHT	★★	NR	TOL k10	166,29	HSSCo 8%	TIN	★★★	NR	TOL k10	190,79	HSSCo 8%	TiAlN	★★★	NR	TOL k10	203,72	HSSCo 8%	BRIGHT	★★	NR	TOL k12	184,66	HSSCo 8%	TIN	★★★	NR	TOL k12	211,75	HSSCo 8%	TiAlN	★★★	NR	TOL k12	222,03	128	26	2	139,57
25,00	154	45	5	3	M12	HSSCo 8%	BRIGHT	★★	NR	TOL k10	150,09	HSSCo 8%	TIN	★★★	NR	TOL k10	184,60	HSSCo 8%	TiAlN	★★★	NR	TOL k10	195,34	HSSCo 8%	BRIGHT	★★	NR	TOL k12	184,71	HSSCo 8%	TIN	★★★	NR	TOL k12	219,32	HSSCo 8%	TiAlN	★★★	NR	TOL k12	229,98	128	26	2	146,69
26,00	147	45	6	3	M12	HSSCo 8%	BRIGHT	★★	NR	TOL k10	151,56	HSSCo 8%	TIN	★★★	NR	TOL k10	191,68	HSSCo 8%	TiAlN	★★★	NR	TOL k10	195,34	HSSCo 8%	BRIGHT	★★	NR	TOL k12	202,91	HSSCo 8%	TIN	★★★	NR	TOL k12	236,05	HSSCo 8%	TiAlN	★★★	NR	TOL k12	247,56	128	26	2	140,00*
28,00	154	50	5	3	M12	HSSCo 8%	BRIGHT	★★	NR	TOL k10	151,56	HSSCo 8%	TIN	★★★	NR	TOL k10	191,68	HSSCo 8%	TiAlN	★★★	NR	TOL k10	195,34	HSSCo 8%	BRIGHT	★★	NR	TOL k12	202,97	HSSCo 8%	TIN	★★★	NR	TOL k12	236,05	HSSCo 8%	TiAlN	★★★	NR	TOL k12	247,56	128	26	2	170,03
30,00	154	50	6	3	M12	HSSCo 8%	BRIGHT	★★	NR	TOL k10	167,47	HSSCo 8%	TIN	★★★	NR	TOL k10	220,24	HSSCo 8%	TiAlN	★★★	NR	TOL k10	224,42	HSSCo 8%	BRIGHT	★★	NR	TOL k12	238,32	HSSCo 8%	TIN	★★★	NR	TOL k12	281,90	HSSCo 8%	TiAlN	★★★	NR	TOL k12	295,63	128	26	2	187,18
32,00	178	53	6	4	M16	HSSCo 8%	BRIGHT	★★	NR	TOL k10	219,99	HSSCo 8%	TIN	★★★	NR	TOL k10	282,60	HSSCo 8%	TiAlN	★★★	NR	TOL k10	287,99	HSSCo 8%	BRIGHT	★★	NR	TOL k12	282,59	HSSCo 8%	TIN	★★★	NR	TOL k12	348,71	HSSCo 8%	TiAlN	★★★	NR	TOL k12	365,65	157	32	2	206,10
36,00	178	53	6	4	M16	HSSCo 8%	BRIGHT	★★	NR	TOL k10	250,58	HSSCo 8%	TIN	★★★	NR	TOL k10	313,00	HSSCo 8%	TiAlN	★★★	NR	TOL k10	322,12	HSSCo 8%	BRIGHT	★★	NR	TOL k12	311,53	HSSCo 8%	TIN	★★★	NR	TOL k12	378,52	HSSCo 8%	TiAlN	★★★	NR	TOL k12	396,93	157	32	2	262,88
40,00	188	63	6	4	M16	HSSCo 8%	BRIGHT	★★	NR	TOL k10	301,89	HSSCo 8%	TIN	★★★	NR	TOL k10	375,65	HSSCo 8%	TiAlN	★★★	NR	TOL k10	386,56	HSSCo 8%	BRIGHT	★★	NR	TOL k12	435,20	HSSCo 8%	TIN	★★★	NR	TOL k12	512,28	HSSCo 8%	TiAlN	★★★	NR	TOL k12	537,18	163	38	2	302,96
45,00	188	63	6	4	M16	HSSCo 8%	BRIGHT	★★	NR	TOL k10	388,81	HSSCo 8%	TIN	★★★	NR	TOL k10	476,04	HSSCo 8%	TiAlN	★★★	NR	TOL k10	489,74	HSSCo 8%	BRIGHT	★★	NR	TOL k12	494,66	HSSCo 8%	TIN	★★★	NR	TOL k12	566,44	HSSCo 8%	TiAlN	★★★	NR	TOL k12	593,98	163	38	2	437,56
50,00	233	75	6	5	M20	HSSCo 8%	BRIGHT	★★	NR	TOL k10	468,40	HSSCo 8%	TIN	★★★	NR	TOL k10	550,10	HSSCo 8%	TiAlN	★★★	NR	TOL k10	565,96	HSSCo 8%	BRIGHT	★★	NR	TOL k12	524,60	HSSCo 8%	TIN	★★★	NR	TOL k12	617,64	HSSCo 8%	TiAlN	★★★	NR	TOL k12	647,64	203	45	2	549,69
56,00	233	75	8	5	M20	HSSCo 8%	BRIGHT	★★	NR	TOL k10	646,16	HSSCo 8%	TIN	★★★	NR	TOL k10	715,59	HSSCo 8%	TiAlN	★★★	NR	TOL k10	736,21	HSSCo 8%	BRIGHT	★★	NR	TOL k12	746,99	HSSCo 8%	TIN	★★★	NR	TOL k12	798,30	HSSCo 8%	TiAlN	★★★	NR	TOL k12	837,11				
63,00	241	90	8	5	M20	HSSCo 8%	BRIGHT	★★	NR	TOL k10	811,25	HSSCo 8%	TIN	★★★	NR	TOL k10	869,30	HSSCo 8%	TiAlN	★★★	NR	TOL k10	894,34	HSSCo 8%	BRIGHT	★★	NR	TOL k12	938,23	HSSCo 8%	TIN	★★★	NR	TOL k12	974,02	HSSCo 8%	TiAlN	★★★	NR	TOL k12	1.021,34				

*Available until end of stock

* Morse taper

TAPER SHANK END MILLS WITHOUT CENTER CUTTING

End mills

Pink

4-8 Z



INOX

Al

LONG SERIES

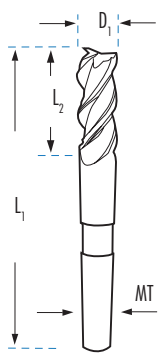

DIN 845B/L						MATERIAL					
						COATING					
ROUGHING						TOLERANCE					
D1 mm	L1 mm	L2 mm	Z	MT*	THREAD	FF11	FF61	FF71	FF12	FF33	FF43
						€	€	€	€	€	€
10,00	115	45	4	1	M6	102,20	124,56	128,78	149,16	170,45	176,24
12,00	138	53	4	2	M6	96,36	124,56	132,43	151,95	172,69	180,21
14,00	138	53	4	2	M10	101,40	135,31	141,20	191,45	211,93	221,18
15,00	138	53	4	2	M10	111,32	141,86	148,02	220,17	243,51	254,17
16,00	148	63	4	2	M10	110,19	138,30	144,33	159,24	185,93	194,05
18,00	148	63	4	2	M10	125,18	151,82	158,41	165,30	191,69	200,05
20,00	160	75	4	2	M10	138,89	169,83	177,22	189,62	219,95	229,53
22,00	160	75	5	2	M10	157,19	186,86	195,89	196,94	226,82	236,71
24,00	192	90	5	3	M12	213,80	241,99	254,89	267,39	295,91	310,80
25,00	184	80	5	3	M12	212,35	249,70	262,39	279,57	315,18	328,92
26,00	192	90	5	3	M12	235,19	269,61	283,32	290,52	325,53	339,74
28,00	192	90	5	3	M12	238,32	285,29	300,50	288,41	325,53	339,74
30,00	192	90	5	3	M12	274,72	320,34	336,60	343,97	389,90	406,93
32,00	229	100	6	4	M16	323,88	379,31	398,57	409,64	465,48	485,83
36,00	231	106	6	4	M16	370,86	425,34	446,92	469,20	523,72	546,58
40,00	250	125	6	4	M16	412,09	478,58	502,90	576,58	640,88	668,89
45,00	250	125	6	4	M16	555,41	636,33	670,29	735,43	809,86	845,25
50,00	268	110	6	5	M20	677,84	745,53	785,34	917,74	982,12	1.025,01
56,00	308	150	8	5	M20	713,33	778,39	821,29	1.069,44	1.125,43	1.185,59
63,00	338	180	8	5	M20	943,54	992,75	1.045,53	1.346,36	1.387,05	1.461,15

* Morse taper

CENTER CUTTING END MILLS IN PLASTIC BOXES

End mills

Pink

2Z  **DIN 327**



4Z  **DIN 844**



REFERENCE	PTF20	PTF60
QUANTITY	8	8
TYPE	Ref. FF02	Ref. FF60
QUALITY	HSSCo 8%	TiAIN
CONTENT	<u>6</u> <u>8</u> <u>10</u> <u>12</u>	<u>6</u> <u>8</u> <u>10</u> <u>12</u>
Ø mm	<u>2</u> <u>2</u> <u>2</u> <u>2</u>	<u>2</u> <u>2</u> <u>2</u> <u>2</u>
PRICE €	152,15	241,25

REFERENCE	PTF24	PTF64
QUANTITY	8	8
TYPE	Ref. FF18	Ref. FF20
QUALITY	HSSCo 8%	TiAIN
CONTENT	<u>6</u> <u>8</u> <u>10</u> <u>12</u>	<u>6</u> <u>8</u> <u>10</u> <u>12</u>
Ø mm	<u>2</u> <u>2</u> <u>2</u> <u>2</u>	<u>2</u> <u>2</u> <u>2</u> <u>2</u>
PRICE €	168,46	255,58

2Z  **DIN 327**



4Z  **DIN 844**



REFERENCE	PTF21	PTF61
QUANTITY	6	6
TYPE	Ref. FF02	Ref. FF60
QUALITY	HSSCo 8%	TiAIN
CONTENT	<u>6-8-10-12-16-20</u>	<u>6-8-10-12-16-20</u>
Ø mm		
PRICE €	164,66	250,50

REFERENCE	PTF25	PTF65
QUANTITY	6	6
TYPE	Ref. FF18	Ref. FF20
QUALITY	HSSCo 8%	TiAIN
CONTENT	<u>6-8-10-12-16-20</u>	<u>6-8-10-12-16-20</u>
Ø mm		
PRICE €	183,88	265,21

2Z  **DIN 327**



4Z  **DIN 844**



REFERENCE	PTF22	PTF62
QUANTITY	6	6
TYPE	Ref. FF18	Ref. FF20
QUALITY	HSSCo 8%	TiAIN
CONTENT	<u>4-5-6-8-10-12</u>	<u>4-5-6-8-10-12</u>
Ø mm		
PRICE €	104,34	167,80

REFERENCE	PTF26	PTF66
QUANTITY	6	6
TYPE	Ref. FF18	Ref. FF20
QUALITY	HSSCo 8%	TiAIN
CONTENT	<u>4-5-6-8-10-12</u>	<u>4-5-6-8-10-12</u>
Ø mm		
PRICE €	115,54	178,15

CENTER CUTTING END MILLS IN METAL BOXES

2Z

DIN
327

REFERENCE	FF010787	FF020787	FT020787	FF600787
QUANTITY	6	6	6	6
TYPE	Ref. FF01	Ref. FF02	Ref. FT02	Ref. FF60
QUALITY	HSS	HSSCo 8%	TiAlSiN	TiAlN
CONTENT Ø mm	4 - 5 - 6 - 8 - 10 - 12	4 - 5 - 6 - 8 - 10 - 12	4 - 5 - 6 - 8 - 10 - 12	4 - 5 - 6 - 8 - 10 - 12
PRICE €	96,58	127,73	148,94	191,18
REFERENCE	FF010447	FF020447	FT020447	FF600447
QUANTITY	6	6	6	6
TYPE	Ref. FF01	Ref. FF02	Ref. FT02	Ref. FF60
QUALITY	HSS	HSSCo 8%	TiAlSiN	TiAlN
CONTENT Ø mm	6 - 8 - 10 - 12 - 16 - 20	6 - 8 - 10 - 12 - 16 - 20	6 - 8 - 10 - 12 - 16 - 20	6 - 8 - 10 - 12 - 16 - 20
PRICE €	144,47	191,59	223,42	277,40

END MILLS IN METAL BOXES

4Z

DIN
844

REFERENCE	FF030787	FF040787	FT040787	FF540787
QUANTITY	6	6	6	6
TYPE	Ref. FF03	Ref. FF04	Ref. FT04	Ref. FF54
QUALITY	HSS	HSSCo 8%	TiAlSiN	TiAlN
CONTENT Ø mm	4 - 5 - 6 - 8 - 10 - 12	4 - 5 - 6 - 8 - 10 - 12	4 - 5 - 6 - 8 - 10 - 12	4 - 5 - 6 - 8 - 10 - 12
PRICE €	94,99	125,28	146,78	191,17
REFERENCE	FF030847	FF040847	FT040847	FF540847
QUANTITY	6	6	6	6
TYPE	Ref. FF03	Ref. FF04	Ref. FT04	Ref. FF54
QUALITY	HSS	HSSCo 8%	TiAlSiN	TiAlN
CONTENT Ø mm	6 - 8 - 10 - 12 - 16 - 20	6 - 8 - 10 - 12 - 16 - 20	6 - 8 - 10 - 12 - 16 - 20	6 - 8 - 10 - 12 - 16 - 20
PRICE €	141,94	190,43	223,14	274,33

REFERENCE	FF250847	FT250847	FF270847
QUANTITY	6	6	6
TYPE	Ref. FF25	Ref. FT25	Ref. FF27
QUALITY	HSSCo 8%	TiAlSiN	TiAlN
CONTENT Ø mm	6 - 8 - 10 - 12 - 16 - 20	6 - 8 - 10 - 12 - 16 - 20	6 - 8 - 10 - 12 - 16 - 20
PRICE €	354,47	413,37	426,37

4Z

DIN
844

NR

END MILLS IN METAL BOXES

4 Z



**DIN
844**

End mills

Pink

REFERENCE	FF180787	FT180787	FF200787
QUANTITY	6	6	6
TYPE	Ref. FF18	Ref. FT18	Ref. FF20
QUALITY	HSSCo 8%	TiAlSiN	TiAlN
CONTENT Ø mm	4 - 5 - 6 - 8 - 10 - 12	4 - 5 - 6 - 8 - 10 - 12	4 - 5 - 6 - 8 - 10 - 12
PRICE €	133,38	155,54	201,52



Ref. FF180787

REFERENCE	FF180847	FT180847	FF200847
QUANTITY	6	6	6
TYPE	Ref. FF18	Ref. FT18	Ref. FF20
QUALITY	HSSCo 8%	TiAlSiN	TiAlN
CONTENT Ø mm	6 - 8 - 10 - 12 - 16 - 20	6 - 8 - 10 - 12 - 16 - 20	6 - 8 - 10 - 12 - 16 - 20
PRICE €	208,51	243,17	289,32



Ref. FF180847

163 END MILLS DISPLAY

Ref. MF-01

MF-01

Content: 163 End mills

Ref. FF13	1 Z	HSSCo	Al	SHORT SERIES	Ø	5 x 8	Shank	6 x 8	Shank								
					Quantity	5		5									
Ref. FF14	1 Z	HSSCo	Al	LONG SERIES	Ø	5 x 8	Shank	6 x 8	Shank								
					Quantity	5		5									
Ref. FF02	2 Z	HSSCo	DIN 327N	30° N	Ø	2	3	4	5	6	7	8	9	10	12	14	16
					Quantity	5	5	5	5	5	5	5	5	5	5	5	5
Ref. FF18	4 Z	HSSCo	DIN 844N	30° N	Ø	2	3	4	5	6	7	8	9	10	12	14	16
					Quantity	5	5	5	5	5	5	5	5	5	5	5	5
Ref. FF25	4 Z	HSSCo	DIN 844N	30° N	NR	Ø	6	7	8	9	10	11	12	14	16		
						Quantity	3	3	3	3	3	3	3	3	3	3	3



Dimensions: width 245 x depth 210 x height 350 mm
NOTE: Special compositions on request

PRICE: **4.311,24 €**

CUTTING CONDITIONS FOR HSSCO 8% END MILLS

		DIAMETER Ø (mm)														
		2	4	6	8	10	12	18	22	26	30	32	36	40		
SOFT STEEL 70 kg/mm ²	V/C 39	RPM	6207	3104	2069	1552	1241	1035	690	564	477	414	388	345	310	
	FEED (mm/min)	Flutes	2	50	56	74	84	82	81	80	81	76	68	68	62	60
		No	3	74	84	112	126	123	121	120	122	115	102	102	93	89
		4	99	112	149	168	164	161	160	163	153	136	137	124	119	
TREATED STEEL 120 kg/mm ²	V/C 20	RPM	3183	1592	1061	796	637	531	354	289	245	212	199	177	159	
	FEED (mm/min)	Flutes	2	25	29	38	43	42	41	41	42	39	35	35	32	31
		No	3	38	43	57	64	63	62	62	63	59	52	53	48	46
		4	51	57	76	86	84	83	82	83	78	70	70	64	61	
STAINLESS STEEL	V/C 15	RPM	2387	1194	796	597	477	398	265	217	184	159	149	133	119	
	FEED (mm/min)	Flutes	2	19	21	29	32	32	31	31	29	26	26	24	23	
		No	3	29	32	43	48	47	47	46	47	44	39	39	36	34
		4	38	43	57	64	63	62	62	63	59	52	53	48	46	
ALUMINIUM	V/C 230	RPM	36606	18303	12202	9151	7321	6101	4067	3328	2816	2440	2288	2034	1830	
	FEED (mm/min)	Flutes	2	293	329	439	494	483	476	472	479	451	400	403	366	351
		No	3	439	494	659	741	725	714	708	719	676	600	604	549	527
		4	586	659	879	988	966	952	944	958	901	800	805	732	703	
TITANIUM	V/C 12	RPM	1910	955	637	477	382	318	212	174	147	127	119	106	95	
	FEED (mm/min)	Flutes	2	15	17	23	26	25	25	25	24	21	21	19	18	
		No	3	23	26	34	39	38	37	37	38	35	31	32	29	28
		4	31	34	46	52	50	50	49	50	47	42	42	38	37	

* In the case of the coated mills the board parameters must be multiplied by 1.3 and for the ASP 60 by 1.8

* V/C: Cutting speed (m/min)

MILLING DEPTH ACCORDING TO TYPE OF MILLING

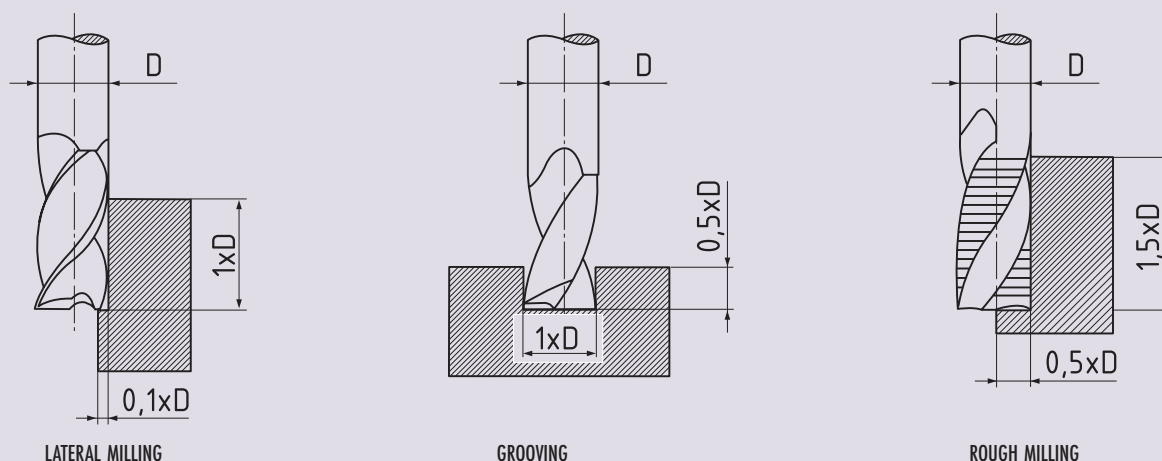



BLUE-MASTER[®]
by *CE/ESA*



SOLID CARBIDE
END MILLS

GENERAL PURPOSE SOLID CARBIDE END MILLS SHORT

End mills

Pink

GENERAL PURPOSE **SOLID CARBIDE** **30° N** **STRAIGHT** **2Z** **3Z**

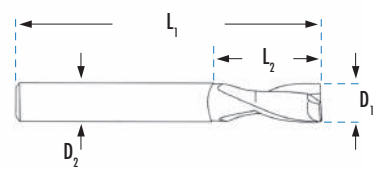

SHORT SERIES

MATERIAL				FMD2		FMD2TL		FMD63		FMD63TL	
COATING				CARBIDE	CARBIDE	CARBIDE	CARBIDE	CARBIDE	CARBIDE	CARBIDE	
QUALITY				BRIGHT	TiAlN	BRIGHT	BRIGHT	TiAlN	BRIGHT	TiAlN	
				★★	★★★	★★	★★	★★★	★★	★★★	
				2Z	2Z	2Z	3Z	3Z	3Z	3Z	
D1 mm	L1 mm	L2 mm	D2 mm	€	€	€	€	€	€	€	
1,00	38	3	3	FMD20100	18,26	FMD20100TIALN	24,21	FMD630100	18,26	FMD630100TIALN	24,21
1,00	50	3	4	FMD20100X50	19,56	FMD20100X50TIALN	26,71	FMD630100X50	19,56	FMD630100X50TIALN	26,71
1,50	38	4	3	FMD20150	18,26	FMD20150TIALN	24,21	FMD630150	18,26	FMD630150TIALN	24,21
1,50	50	4	4	FMD20150X50	19,56	FMD20150X50TIALN	26,71	FMD630150X50	19,56	FMD630150X50TIALN	26,71
2,00	38	6	3	FMD20200	18,26	FMD20200TIALN	24,21	FMD630200	18,26	FMD630200TIALN	24,21
2,00	50	6	4	FMD20200X50	19,56	FMD20200X50TIALN	26,71	FMD630200X50	19,56	FMD630200X50TIALN	26,71
2,50	38	8	3	FMD20250	18,26	FMD20250TIALN	24,21	FMD630250	18,26	FMD630250TIALN	24,21
2,50	50	8	4	FMD20250X50	19,56	FMD20250X50TIALN	26,71	FMD630250X50	19,56	FMD630250X50TIALN	26,71
3,00	38	8	3	FMD20300	17,52	FMD20300TIALN	23,47	FMD630300	17,52	FMD630300TIALN	23,47
3,00	50	8	4	FMD20300X5004	19,26	FMD20300X5004TIALN	27,61	FMD630300X5004	19,26	FMD630300X5004TIALN	27,61
3,00	50	8	6	FMD20300X5006	20,68	FMD20300X5006TIALN	28,86	FMD630300X5006	20,68	FMD630300X5006TIALN	28,86
3,50	50	11	4	FMD20350	20,48	FMD20350TIALN	26,43	FMD630350	20,48	FMD630350TIALN	26,43
4,00	50	11	4	FMD20400	17,41	FMD20400TIALN	23,36	FMD630400	17,41	FMD630400TIALN	23,36
4,00	50	11	6	FMD20400X5006	21,21	FMD20400X5006TIALN	28,96	FMD630400X5006	21,21	FMD630400X5006TIALN	28,96
4,50	50	11	6	FMD20450	22,43	FMD20450TIALN	28,38	FMD630450	22,43	FMD630450TIALN	28,38
5,00	50	13	5	FMD20500	19,77	FMD20500TIALN	25,72	FMD630500	19,77	FMD630500TIALN	25,72
5,00	50	13	6	FMD20500X5006	21,96	FMD20500X5006TIALN	29,15	FMD630500X5006	21,96	FMD630500X5006TIALN	29,15
5,50	50	16	6	FMD20550	21,63	FMD20550TIALN	29,18	FMD630550	21,63	FMD630550TIALN	29,18
6,00	50	16	6	FMD20600	21,63	FMD20600TIALN	27,58	FMD630600	21,63	FMD630600TIALN	27,58
6,00	58	22	6	FMD20600X58	23,25	FMD20600X58TIALN	29,36	FMD630600X58	23,25	FMD630600X58TIALN	29,36
6,35	60	19	8	FMD20635	25,25	FMD20635TIALN	31,25	FMD630635	25,25	FMD630635TIALN	31,25
6,50	60	19	8	FMD20650	28,36	FMD20650TIALN	35,65	FMD630650	28,36	FMD630650TIALN	35,65
7,00	60	19	8	FMD20700	35,39	FMD20700TIALN	42,54	FMD630700	35,39	FMD630700TIALN	42,54
7,50	60	19	8	FMD20750	35,39	FMD20750TIALN	42,54	FMD630750	35,39	FMD630750TIALN	42,54
8,00	60	19	8	FMD20800	32,16	FMD20800TIALN	39,30	FMD630800	32,16	FMD630800TIALN	39,30
8,50	72	22	10	FMD20850	37,37	FMD20850TIALN	44,36	FMD630850	37,37	FMD630850TIALN	44,36
9,00	72	22	10	FMD20900	38,63	FMD20900TIALN	45,36	FMD630900	38,63	FMD630900TIALN	45,36
9,50	72	22	10	FMD20950	51,11	FMD20950TIALN	61,21	FMD630950	51,11	FMD630950TIALN	61,21
10,00	72	22	10	FMD21000	48,30	FMD21000TIALN	56,63	FMD631000	48,30	FMD631000TIALN	56,63
10,00	80	32	10	FMD21000X80	52,36	FMD21000X80TIALN	60,12	FMD631000X80	52,36	FMD631000X80TIALN	60,12
10,50	75	26	12	FMD21050	52,36	FMD21050TIALN	61,11	FMD631050	52,36	FMD631050TIALN	61,11
11,00	75	26	12	FMD21100	70,67	FMD21100TIALN	80,19	FMD631100	70,67	FMD631100TIALN	80,19
12,00	75	26	12	FMD21200	61,59	FMD21200TIALN	71,10	FMD631200	61,59	FMD631200TIALN	71,10
12,50	84	30	14	FMD21250	62,63	FMD21250TIALN	71,11	FMD631250	62,63	FMD631250TIALN	71,11
13,00	84	30	14	FMD21300	63,36	FMD21300TIALN	71,25	FMD631300	63,36	FMD631300TIALN	71,25
14,00	84	30	14	FMD21400	94,63	FMD21400TIALN	106,54	FMD631400	94,63	FMD631400TIALN	106,54
14,00	100	50	14	FMD21400X100	105,36	FMD21400X100TIALN	118,36	FMD631400X100	105,36	FMD631400X100TIALN	118,36
15,00	92	32	16	FMD21500	108,25	FMD21500TIALN	121,25	FMD631500	108,25	FMD631500TIALN	121,25
16,00	92	32	16	FMD21600	122,26	FMD21600TIALN	135,36	FMD631600	122,26	FMD631600TIALN	135,36
16,00	100	50	16	FMD21600X100	131,36	FMD21600X100TIALN	145,36	FMD631600X100	131,36	FMD631600X100TIALN	145,36
17,00	100	38	18	FMD21700	124,36	FMD21700TIALN	138,96	FMD631700	124,36	FMD631700TIALN	138,96
18,00	100	38	18	FMD21800	179,14	FMD21800TIALN	197,00	FMD631800	179,14	FMD631800TIALN	197,00
18,00	100	50	18	FMD21800X10050	196,36	FMD21800X10050TIALN	216,36	FMD631800X10050	196,36	FMD631800X10050TIALN	216,36
19,00	100	38	20	FMD21900	201,36	FMD21900TIALN	221,36	FMD631900	201,36	FMD631900TIALN	221,36
20,00	100	38	20	FMD22000	203,76	FMD22000TIALN	226,38	FMD632000	203,76	FMD632000TIALN	226,38
20,00	100	50	20	FMD22000X10050	215,36	FMD22000X10050TIALN	238,36	FMD632000X10050	215,36	FMD632000X10050TIALN	238,36
22,00	100	38	22	FMD22200	289,36	FMD22200TIALN	325,36	FMD632200	289,36	FMD632200TIALN	325,36
25,00	100	45	25	FMD22500	353,57	FMD22500TIALN	388,10	FMD632500	353,57	FMD632500TIALN	388,10
25,00	110	55	25	FMD22500X110	389,36	FMD22500X110TIALN	436,36	FMD632500X110	389,36	FMD632500X110TIALN	436,36



FMD2 FMD63

44 HRC

GENERAL PURPOSE SOLID CARBIDE END MILLS SHORT

**GENERAL
PURPOSE**

**SOLID
CARBIDE**



STRAIGHT

4Z



**TOL D1
+0 -0,05**

**TOL D2
h6**

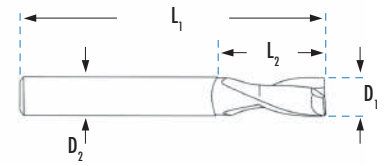

SHORT SERIES

MATERIAL COATING QUALITY				FMD48	FMD48TL
D1 mm	L1 mm	L2 mm	D2 mm	CARBIDE	CARBIDE
1,00	38	3	3	BRIGHT	TiAlN
1,00	50	3	4	★★	★★★
1,50	38	4	3	4Z	4Z
1,50	50	4	4	€	€
2,00	38	6	3	FMD480100	FMD480100TIALN
2,00	50	6	4	FMD480100X50	FMD480100X50TIALN
2,50	38	8	3	FMD480150	FMD480150TIALN
2,50	50	8	4	FMD480150X50	FMD480150X50TIALN
3,00	38	8	3	FMD480200	FMD480200TIALN
3,00	50	8	4	FMD480200X50	FMD480200X50TIALN
3,50	50	11	4	FMD480250	FMD480250TIALN
4,00	50	11	4	FMD480250X50	FMD480250X50TIALN
4,50	50	11	6	FMD480300	FMD480300TIALN
5,00	50	13	5	FMD480300X5004	FMD480300X5004TIALN
5,50	50	16	6	FMD480300X5006	FMD480300X5006TIALN
6,00	50	16	6	FMD480350	FMD480350TIALN
6,35	60	19	8	FMD480400	FMD480400TIALN
6,50	60	19	8	FMD480400X5006	FMD480400X5006TIALN
7,00	60	19	8	FMD480450	FMD480450TIALN
7,50	60	19	8	FMD480500	FMD480500TIALN
8,00	60	19	8	FMD480500X5006	FMD480500X5006TIALN
8,50	72	22	10	FMD480550	FMD480550TIALN
9,00	72	22	10	FMD480600	FMD480600TIALN
9,50	72	22	10	FMD480600X58	FMD480600X58TIALN
10,00	72	22	10	FMD480635	FMD480635TIALN
10,50	75	26	12	FMD480650	FMD480650TIALN
11,00	75	26	12	FMD480700	FMD480700TIALN
11,50	75	26	12	FMD480750	FMD480750TIALN
12,00	75	26	12	FMD480800	FMD480800TIALN
12,50	84	30	14	FMD480850	FMD480850TIALN
13,00	84	30	14	FMD480900	FMD480900TIALN
13,50	84	30	14	FMD480950	FMD480950TIALN
14,00	84	30	14	FMD481000	FMD481000TIALN
14,50	100	50	14	FMD481000X80	FMD481000X80TIALN
15,00	92	32	16	FMD481050	FMD481050TIALN
15,50	92	32	16	FMD481100	FMD481100TIALN
16,00	92	32	16	FMD481200	FMD481200TIALN
16,50	100	50	16	FMD481250	FMD481250TIALN
17,00	100	38	18	FMD481300	FMD481300TIALN
17,50	100	38	18	FMD481400	FMD481400TIALN
18,00	100	38	18	FMD481400X100	FMD481400X100TIALN
18,50	100	50	18	FMD481500	FMD481500TIALN
19,00	100	38	20	FMD481600	FMD481600TIALN
19,50	100	38	20	FMD481600X100	FMD481600X100TIALN
20,00	100	38	20	FMD481700	FMD481700TIALN
20,50	100	50	20	FMD481800	FMD481800TIALN
21,00	100	38	22	FMD481800X10050	FMD481800X10050TIALN
21,50	100	38	22	FMD481900	FMD481900TIALN
22,00	100	38	22	FMD482000	FMD482000TIALN
22,50	100	45	25	FMD482000X10050	FMD482000X10050TIALN
23,00	100	38	22	FMD482200	FMD482200TIALN
23,50	100	45	25	FMD482500	FMD482500TIALN
24,00	110	55	25	FMD482500X110	FMD482500X110TIALN



FMD48 FMD48TL



**44
HRc**

GENERAL PURPOSE SOLID CARBIDE END MILLS LONG SERIES

End mills

Pink

GENERAL PURPOSE **SOLID CARBIDE** **30° N** **STRAIGHT** **2Z** **3Z** **4Z**

LONG SERIES

MATERIAL COATING QUALITY				FMD54	FMD54TL	NEW FMD73	NEW FMD73TL
D1 mm	L1 mm	L2 mm	D2 mm	CARBIDE BRIGHT ** 2Z €	CARBIDE TiAlN *** 2Z €	CARBIDE BRIGHT ** 3Z €	CARBIDE TiAlN ** 3Z €
1,00	60	5	3	FMD540100 18,41	FMD540100TIALN 25,55	FMD730100 18,41	FMD730100TIALN 25,55
2,00	60	10	3	FMD540200 18,89	FMD540200TIALN 26,03	FMD730200 18,89	FMD730200TIALN 26,03
3,00	60	15	3	FMD540300 19,40	FMD540300TIALN 26,54	FMD730300 19,40	FMD730300TIALN 26,54
4,00	80	20	4	FMD540400 20,45	FMD540400TIALN 27,58	FMD730400 20,45	FMD730400TIALN 27,58
5,00	80	25	5	FMD540500 25,45	FMD540500TIALN 32,59	FMD730500 25,45	FMD730500TIALN 32,59
6,00	80	25	6	FMD540600 35,89	FMD540600TIALN 43,02	FMD730600 35,89	FMD730600TIALN 43,02
7,00	90	35	8	FMD540700 37,85	FMD540700TIALN 47,69	FMD730700 37,85	FMD730700TIALN 47,69
8,00	90	35	8	FMD540800 40,86	FMD540800TIALN 50,39	FMD730800 40,86	FMD730800TIALN 50,39
9,00	100	45	10	FMD540900 53,36	FMD540900TIALN 64,25	FMD730900 53,36	FMD730900TIALN 64,25
10,00	100	45	10	FMD541000 57,74	FMD541000TIALN 67,27	FMD731000 57,74	FMD731000TIALN 67,27
12,00	100	50	12	FMD541200 78,82	FMD541200TIALN 90,73	FMD731200 78,82	FMD731200TIALN 90,73
14,00	150	65	14	FMD541400 129,70	FMD541400TIALN 145,17	FMD731400 129,70	FMD731400TIALN 145,17
16,00	150	65	16	FMD541600 142,10	FMD541600TIALN 157,57	FMD731600 142,10	FMD731600TIALN 157,57
16,00	150	90	16	FMD541600X15090 156,30	FMD541600X15090TIALN 173,33	FMD731600X15090 156,30	FMD731600X15090TIALN 173,33
20,00	150	70	20	FMD542000 252,06	FMD542000TIALN 275,88	FMD732000 252,06	FMD732000TIALN 275,88
25,00	150	75	25	FMD542500 496,36	FMD542500TIALN 523,31	FMD732500 496,36	FMD732500TIALN 523,31



FMD54 FMD73

44 HRC

LONG SERIES

MATERIAL COATING QUALITY				FMD58	FMD58TL
D1 mm	L1 mm	L2 mm	D2 mm	CARBIDE BRIGHT ** 4Z €	CARBIDE TiAlN *** 4Z €
1,00	60	5	3	FMD580100 18,41	FMD580100TIALN 25,55
2,00	60	10	3	FMD580200 18,89	FMD580200TIALN 26,03
3,00	60	15	3	FMD580300 19,40	FMD580300TIALN 26,54
4,00	80	20	4	FMD580400 20,45	FMD580400TIALN 27,58
5,00	80	25	5	FMD580500 25,45	FMD580500TIALN 32,59
6,00	80	25	6	FMD580600 35,89	FMD580600TIALN 43,02
7,00	90	35	8	FMD580700 37,85	FMD580700TIALN 47,69
8,00	90	35	8	FMD580800 40,86	FMD580800TIALN 50,39
9,00	100	45	10	FMD580900 53,36	FMD580900TIALN 64,25
10,00	100	45	10	FMD581000 57,74	FMD581000TIALN 67,27
12,00	100	50	12	FMD581200 78,82	FMD581200TIALN 90,73
14,00	150	65	14	FMD581400 129,70	FMD581400TIALN 145,17
16,00	150	65	16	FMD581600 142,10	FMD581600TIALN 157,57
16,00	150	90	16	FMD581600X15090 156,30	FMD581600X15090TIALN 173,33
20,00	150	70	20	FMD582000 252,06	FMD582000TIALN 275,88
25,00	150	75	25	FMD582500 496,36	FMD582500TIALN 523,31



FMD58 FMD58TL

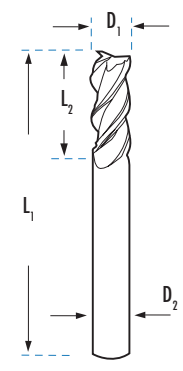

44 HRC

GENERAL PURPOSE SOLID CARBIDE END MILLS EXTRA LONG SERIES

**GENERAL
PURPOSE**

**SOLID
CARBIDE**

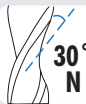

STRAIGHT

2Z



4Z

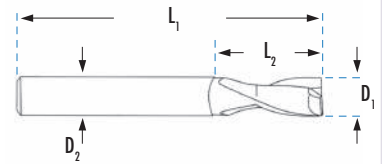

End mills

EXTRA LONG SERIES

Ø mm	L1 mm	L2 mm	D2 mm	MATERIAL COATING QUALITY	FMD53		FMD53TL		FMD56		FMD56TL	
					CARBIDE BRIGHT ★★ 2Z €	CARBIDE TiAlN ★★★ 2Z €	CARBIDE BRIGHT ★★ 4Z €	CARBIDE TiAlN ★★★ 4Z €				
3,00	75	25	3	FMD530300	41,71	FMD530300TiAlN	53,62	FMD560300	43,16	FMD560300TiAlN	55,07	
3,00	100	25	3	FMD530300X100	44,46	FMD530300X100TiAlN	56,54	FMD560300X100	45,66	FMD560300X100TiAlN	57,36	
4,00	100	25	4	FMD530400	45,32	FMD530400TiAlN	57,23	FMD560400	46,74	FMD560400TiAlN	58,65	
5,00	100	25	5	FMD530500	51,22	FMD530500TiAlN	63,13	FMD560500	53,82	FMD560500TiAlN	65,73	
6,00	100	25	6	FMD530600X10025	77,25	FMD530600X10025TiAlN	96,96	FMD560600X10025	79,57	FMD560600X10025TiAlN	99,87	
6,00	100	40	6	FMD530600X10040	78,85	FMD530600X10040TiAlN	98,11	FMD560600X10040	81,22	FMD560600X10040TiAlN	101,05	
6,00	150	25	6	FMD530600X15025	80,80	FMD530600X15025TiAlN	99,36	FMD560600X15025	83,22	FMD560600X15025TiAlN	102,34	
6,00	150	40	6	FMD530600X15040	83,36	FMD530600X15040TiAlN	102,25	FMD560600X15040	85,86	FMD560600X15040TiAlN	105,32	
6,00	150	75	6	FMD530600	85,49	FMD530600TiAlN	104,54	FMD560600	90,42	FMD560600TiAlN	108,73	
8,00	100	45	8	FMD530800X10045	106,33	FMD530800X10045TiAlN	132,36	FMD560800X10045	109,52	FMD560800X10045TiAlN	136,33	
8,00	150	25	8	FMD530800X15025	111,11	FMD530800X15025TiAlN	135,37	FMD560800X15025	114,44	FMD560800X15025TiAlN	139,43	
8,00	150	45	8	FMD530800X15045	114,45	FMD530800X15045TiAlN	137,89	FMD560800X15045	117,88	FMD560800X15045TiAlN	142,03	
8,00	150	75	8	FMD530800	117,71	FMD530800TiAlN	140,34	FMD560800	124,50	FMD560800TiAlN	146,25	
10,00	150	38	10	FMD531000X15038	137,36	FMD531000X15038TiAlN	169,69	FMD561000X15038	141,48	FMD561000X15038TiAlN	174,78	
10,00	150	50	10	FMD531000X15050	141,41	FMD531000X15050TiAlN	172,25	FMD561000X15050	145,65	FMD561000X15050TiAlN	177,42	
10,00	150	65	10	FMD531000X15065	145,36	FMD531000X15065TiAlN	175,75	FMD561000X15065	149,72	FMD561000X15065TiAlN	181,02	
10,00	150	75	10	FMD531000	149,10	FMD531000TiAlN	178,87	FMD561000	164,01	FMD561000TiAlN	193,77	
12,00	150	38	12	FMD531200X15038	199,96	FMD531200X15038TiAlN	241,14	FMD561200X15038	205,96	FMD561200X15038TiAlN	248,37	
12,00	150	50	12	FMD531200X15050	205,36	FMD531200X15050TiAlN	247,47	FMD561200X15050	211,52	FMD561200X15050TiAlN	254,89	
12,00	150	75	12	FMD531200	218,16	FMD531200TiAlN	256,26	FMD561200	239,97	FMD561200TiAlN	278,08	
12,00	200	38	12	FMD531200X20038	231,25	FMD531200X20038TiAlN	272,36	FMD561200X20038	258,36	FMD561200X20038TiAlN	281,11	
14,00	150	75	14	FMD531400	301,59	FMD531400TiAlN	348,03	FMD561400	331,75	FMD561400TiAlN	378,19	
16,00	200	75	16	FMD531600	409,75	FMD531600TiAlN	463,33	FMD561600	450,73	FMD561600TiAlN	504,31	
20,00	200	75	20	FMD532000	639,35	FMD532000TiAlN	710,79	FMD562000	639,35	FMD562000TiAlN	710,79	



FMD53 FMD56



Pink

GENERAL PURPOSE SOLID CARBIDE BALL NOSE END MILLS SHORT & LONG SERIES

End mills

Pink

GENERAL PURPOSE **SOLID CARBIDE** **30° N** **STRAIGHT** **2Z** **4Z**

SHORT SERIES

MATERIAL				FMD92		FMD92TL		FMD51		FMD51TL	
COATING				CARBIDE	CARBIDE	CARBIDE	CARBIDE	CARBIDE	CARBIDE	CARBIDE	
QUALITY				BRIGHT	BRIGHT	TiAlN	BRIGHT	BRIGHT	TiAlN	TiAlN	
				★★	★★★	★★★	★★	★★	★★★	★★★	
				2Z	2Z	2Z	4Z	4Z	4Z	4Z	
D1 mm	L1 mm	L2 mm	D2 mm	€	€	€	€	€	€	€	
1,00	38	2	3	FMD920100 21,91	FMD920100TIALN 27,86	FMD510100	FMD510100TIALN				
1,00	50	2	4	FMD920100X50 26,56	FMD920100X50TIALN 34,12	FMD510100X50	FMD510100X50TIALN				
1,50	38	3	3	FMD920150 21,91	FMD920150TIALN 27,86	FMD510150	FMD510150TIALN				
1,50	50	3	4	FMD920150X50 26,56	FMD920150X50TIALN 34,12	FMD510150X50	FMD510150X50TIALN				
2,00	38	4	3	FMD920200 21,91	FMD920200TIALN 27,86	FMD510200	FMD510200TIALN				
2,00	50	4	4	FMD920200X50 26,56	FMD920200X50TIALN 34,12	FMD510200X50	FMD510200X50TIALN				
2,50	38	5	3	FMD920250 21,91	FMD920250TIALN 27,86	FMD510250X50	FMD510250X50TIALN				
3,00	38	6	3	FMD920300 21,91	FMD920300TIALN 27,86	FMD510300	FMD510300TIALN	24,11		30,65	
3,00	50	6	4	FMD920300X50 26,56	FMD920300X50TIALN 34,12	FMD510300X50	FMD510300X50TIALN				
4,00	50	8	4	FMD920400 24,97	FMD920400TIALN 30,92	FMD510400	FMD510400TIALN	27,47		34,01	
5,00	50	10	5	FMD920500 26,42	FMD920500TIALN 32,38	FMD510500	FMD510500TIALN	29,06		35,61	
6,00	50	12	6	FMD920600 31,09	FMD920600TIALN 37,04	FMD510600	FMD510600TIALN	34,21		40,75	
7,00	60	15	8	FMD920700 37,85*	FMD920700TIALN 44,25	FMD510700	FMD510700TIALN	40,55		47,96	
8,00	60	15	8	FMD920800 38,38	FMD920800TIALN 45,52	FMD510800	FMD510800TIALN	47,99		56,91	
10,00	75	20	10	FMD921000 57,67	FMD921000TIALN 66,00	FMD511000	FMD511000TIALN	72,07		82,50	
12,00	75	20	12	FMD921200 71,65	FMD921200TIALN 81,17	FMD511200	FMD511200TIALN	89,55		101,46	
14,00	90	25	14	FMD921400 106,06	FMD921400TIALN 117,97	FMD511400	FMD511400TIALN	132,58		147,46	
16,00	100	25	16	FMD921600 134,19	FMD921600TIALN 147,28	FMD511600	FMD511600TIALN	167,74		184,11	
18,00	100	30	18	FMD921800 199,51	FMD921800TIALN 217,37	FMD511800	FMD511800TIALN	249,39		271,72	
20,00	100	30	20	FMD922000 206,84	FMD922000TIALN 229,46	FMD512000	FMD512000TIALN	258,53		286,82	

TOL D1 +0 -0,05
TOL D2 h6



FMD92 FMD51

44 HRc

*Available until end of stock

LONG SERIES

MATERIAL				FMD57		FMD57TL	
COATING				CARBIDE	CARBIDE	CARBIDE	CARBIDE
QUALITY				BRIGHT	BRIGHT	TiAlN	TiAlN
				★★	★★★	★★★	★★★
				2Z	2Z	2Z	2Z
D1 mm	L1 mm	L2 mm	D2 mm	€	€	€	€
1,00	60	2	3	FMD570100 33,03	FMD570100TIALN 40,18		
1,50	60	3	3	FMD570150 33,03	FMD570150TIALN 40,18		
2,00	60	3	3	FMD570200 33,03	FMD570200TIALN 40,18		
2,50	60	3	3	FMD570250 33,03	FMD570250TIALN 40,18		
3,00	60	4	3	FMD570300 33,03	FMD570300TIALN 40,18		
4,00	80	5	4	FMD570400 38,34	FMD570400TIALN 45,49		
5,00	80	6	5	FMD570500 45,35	FMD570500TIALN 52,50		
6,00	80	8	6	FMD570600 53,01	FMD570600TIALN 60,14		
8,00	100	12	8	FMD570800 69,96	FMD570800TIALN 79,49		
10,00	100	15	10	FMD571000 86,44	FMD571000TIALN 97,16		
12,00	100	15	12	FMD571200 149,80	FMD571200TIALN 161,71		
14,00	150	20	14	FMD571400 187,83	FMD571400TIALN 203,32		
16,00	150	20	16	FMD571600 237,24	FMD571600TIALN 252,72		
20,00	150	25	20	FMD572000 489,69	FMD572000TIALN 513,50		



FMD57 FMD57TL

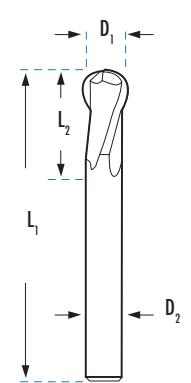

44 HRc

GENERAL PURPOSE SOLID CARBIDE BALL NOSE END MILLS EXTRA LONG SERIES

**GENERAL
PURPOSE**

**SOLID
CARBIDE**

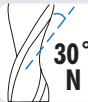

30°
N



STRAIGHT

2Z

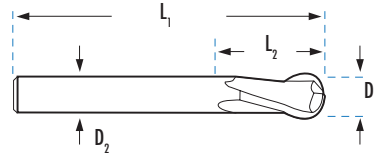

EXTRA LONG SERIES

MATERIAL COATING QUALITY				FMD55		FMD55TL	
D ₁ mm	L ₁ mm	L ₂ mm	D ₂ mm	CARBIDE BRIGHT ★★ 2Z €	CARBIDE TiAlN ★★★ 2Z €		
3,00	75	6	3	FMD550300	39,59	FMD550300TiAlN	51,50
3,00	100	6	3	FMD550300X100	42,42	FMD550300X100TiAlN	55,36
4,00	100	6	4	FMD550400	45,67	FMD550400TiAlN	57,57
5,00	100	6	5	FMD550500	55,19	FMD550500TiAlN	67,10
6,00	100	15	6	FMD550600	69,36	FMD550600TiAlN	81,27
6,00	150	15	6	FMD550600X150	81,81	FMD550600X150TiAlN	96,31
6,00	200	30	6	FMD550600X200	96,36	FMD550600X200TiAlN	109,12
8,00	150	25	8	FMD550800	93,17	FMD550800TiAlN	111,03
8,00	200	50	8	FMD550800X200	112,12	FMD550800X200TiAlN	132,11
10,00	150	25	10	FMD551000	131,27	FMD551000TiAlN	149,13
10,00	200	50	10	FMD551000X200	149,99	FMD551000X200TiAlN	171,71
12,00	150	25	12	FMD551200	208,78	FMD551200TiAlN	242,11
12,00	200	25	12	FMD551200X200	256,36	FMD551200X200TiAlN	294,22
14,00	200	50	14	FMD551400	256,40	FMD551400TiAlN	294,51
16,00	200	50	16	FMD551600	344,51	FMD551600TiAlN	386,18



FMD55 FMD55TL



RECOMMENDED CUTTING SPEED

		Ø2	Ø3	Ø4	Ø5	Ø6	Ø8	Ø10	Ø12	Ø14
	RPM	4000	2600	2000	1600	1300	1000	800	660	570
	FEED (mm/min)	50	55	55	55	55	55	55	55	55
	RPM	8000	5300	4000	3200	2600	2000	1600	1300	1100
	FEED (mm/min)	55	55	55	55	60	60	60	60	60
	RPM	16000	11000	8000	6400	5300	4000	3200	2600	2300
	FEED (mm/min)	290	290	290	290	290	290	290	290	300

* To obtain cutting conditions for end mills TiAlN coated, you have to multiply the figures by 1,3.

HIGH PERFORMANCE SOLID CARBIDE END MILLS

End mills

Pink

GENERAL PURPOSE **SOLID CARBIDE** **STRAIGHT** **2Z** **3Z** **4Z** **HIGH MACHINING PERFORMANCE** **Micro Grain CARBIDE**

SHORT SERIES

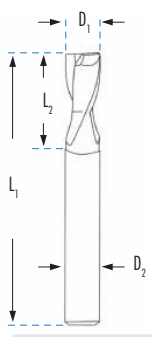

TOL D1 +0 -0,05
TOL D2 h6



VARIABLE HELIX

				FMT2	FMT63	FMT48
				30° N	30° N	30° N
				CARBIDE	CARBIDE	CARBIDE
				TiAlSiN	TiAlSiN	TiAlSiN
				Premium Quality	Premium Quality	Premium Quality
				2Z	3Z	4Z
D1 mm	L1 mm	L2 mm	D2 mm	€	€	€
1,00	38	3	3	45,85	45,85	45,85
1,50	38	4	3	44,77	44,77	44,77
2,00	38	6	3	35,63	35,63	35,63
2,50	38	8	3	34,82	34,82	34,82
3,00	38	8	3	29,99	29,99	29,99
3,50	50	11	4	36,81	36,81	36,81
4,00	50	11	4	34,20	34,20	34,20
4,50	50	13	5	43,74	43,74	43,74
5,00	50	13	5	43,21	43,21	43,21
6,00	50	16	6	48,71	48,71	48,71
7,00	60	16	8	67,94	67,94	67,94
8,00	60	19	8	57,66	57,66	57,66
9,00	72	19	10	82,67	82,67	82,67
10,00	72	22	10	91,92	91,92	91,92
11,00	75	26	12	122,27	122,27	122,27
12,00	75	26	12	113,69	113,69	113,69
14,00	84	30	14	169,00	169,00	169,00
16,00	92	32	16	218,92	218,92	218,92
18,00	100	38	18	304,21	304,21	304,21
20,00	100	38	20	346,83	346,83	346,83
25,00	100	38	25	569,30	569,30	569,30

				FMT81
				35° / 38° N
				CARBIDE
				TiAlSiN
				Premium Quality
				4Z
D1 mm	L1 mm	L2 mm	D2 mm	€
1,00	38	3	3	
1,50	38	5	3	
2,00	38	6	3	
2,50	38	7	3	
3,00	38	12	3	
3,50	50	12	4	
4,00	50	14	4	
4,50	50	14	5	
5,00	50	16	5	47,54
6,00	63	19	6	53,59
7,00	63	19	8	
8,00	63	19	8	63,42
9,00	70	22	10	
10,00	70	22	10	101,10
11,00	75	25	11	
12,00	75	25	12	125,05
14,00	88	30	14	185,89
16,00	88	32	16	240,81
18,00	100	36	18	334,62
20,00	100	36	20	381,51
25,00	100	38	25	

				FMT92
				30° N
				CARBIDE
				TiAlSiN
				Premium Quality
				2Z
D1 mm	L1 mm	L2 mm	D2 mm	€
1,00	38	2	3	
1,50	38	3	3	
2,00	38	4	3	
2,50	38	5	3	
3,00	38	6	3	39,59
4,00	50	8	4	43,92
5,00	50	10	5	54,29
6,00	50	12	6	62,11
8,00	60	15	8	76,36
10,00	75	20	10	110,69
12,00	75	20	12	136,13
14,00	90	25	14	197,84
16,00	100	25	16	247,01
18,00	100	30	18	364,56
20,00	100	30	20	384,81

* FMT81: Variable helix TiAlSiN coated: minimizes the vibrations and allows an impressive efficiency during the machining

RECOMMENDED CUTTING SPEED

		Ø 2	Ø 3	Ø 4	Ø 5	Ø 6	Ø 8	Ø 10	Ø 12	Ø 14	Ø 16	Ø 20	Ø 25
	RPM	5600	3640	2800	2240	1820	1400	1120	924	798	700	560	420
	FEED (mm/min)	70	77	77	77	77	77	77	77	77	91	91	70
INOX Ti	RPM	11200	7420	5600	4480	3640	2800	2240	1820	1540	1400	1120	840
	FEED (mm/min)	77	77	77	77	84	84	84	84	84	98	98	77
Ni	RPM	11200	7420	5600	4480	3640	2800	2240	1820	1540	1400	1120	840
	FEED (mm/min)	77	77	77	77	84	84	84	84	84	98	98	77

SOLID CARBIDE TORIC END MILL

NEW
Ref. FMG10R
Ref. FMG54R

**TORIC
GENERAL
PURPOSE**

**SOLID
CARBIDE**



STRAIGHT

TiAlN

2 Z



4 Z



**Micro Grain
CARBIDE**

End mills

Pink

					FMG10R		FMG54R	
MATERIAL					CARBIDE		CARBIDE	
COATING					TiAlN		TiAlN	
QUALITY					★★		★★★	
					2Z		4Z	
D1 mm	D2 mm	R mm	L2 mm	L1 mm		€		€
2	6	0,2	6	50	FMG100200R0,2	27,39	FMG540200R0,2	27,39
2	6	0,5	6	50	FMG100200R0,5	27,39	FMG540200R0,5	27,39
3	6	0,2	8	50	FMG100300R0,2	27,39	FMG540300R0,2	27,39
3	6	0,5	8	50	FMG100300R0,5	27,39	FMG540300R0,5	27,39
4	6	0,2	11	50	FMG100400R0,2	27,39	FMG540400R0,2	27,39
4	6	0,5	11	50	FMG100400R0,5	27,39	FMG540400R0,5	27,39
4	6	1,0	11	50	FMG100400R1	27,39	FMG540400R1	27,39
5	6	0,2	12	50	FMG100500R0,2	27,39	FMG540500R0,2	27,39
5	6	0,5	12	50	FMG100500R0,5	27,39	FMG540500R0,5	27,39
5	6	1,0	12	50	FMG100500R1	27,39	FMG540500R1	27,39
6	6	0,2	12	50	FMG100600R0,2	27,39	FMG540600R0,2	27,39
6	6	0,5	13	50	FMG100600R0,5	27,39	FMG540600R0,5	27,39
6	6	1,0	13	50	FMG100600R1	27,39	FMG540600R1	27,39
6	6	1,5	13	50	FMG100600R1,5	27,39	FMG540600R1,5	27,39
6	6	2,0	13	50	FMG100600R2	27,39	FMG540600R2	27,39
8	8	0,2	15	60	FMG100800R0,2	37,70	FMG540800R0,2	37,70
8	8	0,5	15	60	FMG100800R0,5	37,70	FMG540800R0,5	37,70
8	8	1,0	15	60	FMG100800R1	37,70	FMG540800R1	37,70
8	8	1,5	15	60	FMG100800R1,5	37,70	FMG540800R1,5	37,70
8	8	2,0	15	60	FMG100800R2	37,70	FMG540800R2	37,70
10	10	0,5	20	72	FMG101000R0,5	51,91	FMG541000R0,5	51,91
10	10	1,0	20	72	FMG101000R1	51,91	FMG541000R1	51,91
10	10	1,5	20	72	FMG101000R1,5	51,91	FMG541000R1,5	51,91
10	10	2,0	20	72	FMG101000R2	51,91	FMG541000R2	51,91
10	10	3,0	20	72	FMG101000R3	51,91	FMG541000R3	51,91
12	12	0,5	24	75	FMG101200R0,5	73,32	FMG541200R0,5	73,32
12	12	1,0	24	75	FMG101200R1	73,32	FMG541200R1	73,32
12	12	1,5	24	75	FMG101200R1,5	73,32	FMG541200R1,5	73,32
12	12	2,0	24	75	FMG101200R2	73,32	FMG541200R2	73,32
12	12	3,0	24	75	FMG101200R3	73,32	FMG541200R3	73,32
16	16	0,5	30	92	FMG101600R0,5	137,63	FMG541600R0,5	137,63
16	16	1,0	30	92	FMG101600R1	137,63	FMG541600R1	137,63
16	16	2,0	30	92	FMG101600R2	137,63	FMG541600R2	137,63
16	16	3,0	30	92	FMG101600R3	137,63	FMG541600R3	137,63
16	16	4,0	30	92	FMG101600R4	137,63	FMG541600R4	137,63

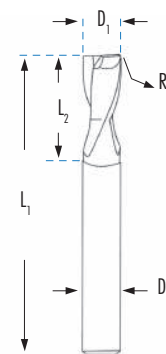

SOLID CARBIDE MICRO END MILLS

End mills

Pink

NEW

Ref. FMD22
Ref. FMD35

GENERAL PURPOSE MICRO

SOLID CARBIDE



STRAIGHT

TiAlN

2 Z



Micro Grain CARBIDE

WITHOUT NECK

44 HRc

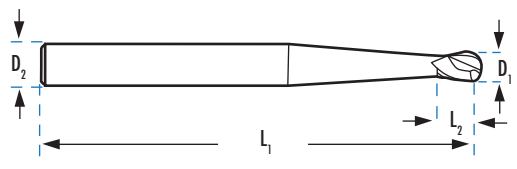

	FMD22					
	TOL -0,015	TOL h6				€
	D1 mm	D2 mm	L2 mm	L1 mm		
FMD220020X04	0,2	4	0,4	50	38,57	
FMD220030X06	0,3	4	0,6	50	36,78	
FMD220040X08	0,4	4	0,8	50	34,41	
FMD220050X10	0,5	4	1,0	50	32,50	
FMD220060X12	0,6	4	1,2	50	32,50	
FMD220070X14	0,7	4	1,4	50	32,50	
FMD220080X16	0,8	4	1,6	50	32,50	
FMD220090X18	0,9	4	1,8	50	32,50	



BALL NOSE

	FMD35					
	TOL -0,015	TOL h6				€
	D1 mm	D2 mm	L2 mm	L1 mm		
FMD350020X04	0,2	4	0,4	50	48,45	
FMD350030X06	0,3	4	0,6	50	44,63	
FMD350040X08	0,4	4	0,8	50	39,09	
FMD350050X10	0,5	4	1,0	50	37,21	
FMD350060X12	0,6	4	1,2	50	37,21	
FMD350070X14	0,7	4	1,4	50	37,21	
FMD350080X16	0,8	4	1,6	50	37,21	
FMD350090X18	0,9	4	1,8	50	37,21	



WITH NECK

44 HRc

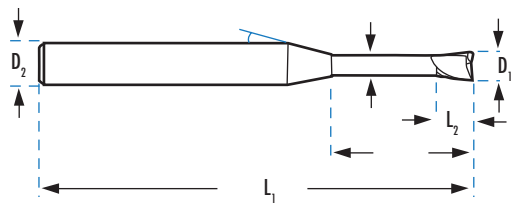

	FMD22						
	TOL -0,015	TOL h6					€
	D1 mm	D2 mm	D3 mm	L3 mm	L2 mm	L1 mm	
FMD220050X04	0,5	4	0,48	4	0,7	50	34,58
FMD220050X06	0,5	4	0,48	6	0,7	50	34,58
FMD220060X04	0,6	4	0,57	4	0,9	50	34,58
FMD220060X06	0,6	4	0,57	6	0,9	50	34,58
FMD220060X08	0,6	4	0,57	8	0,9	50	34,58
FMD220080X06	0,8	4	0,76	6	1,2	50	34,58
FMD220080X08	0,8	4	0,76	8	1,2	50	34,58
FMD220080X10	0,8	4	0,76	10	1,2	50	34,58
FMD220120X06	1,2	4	1,15	6	1,8	50	23,40
FMD220120X08	1,2	4	1,15	8	1,8	50	23,40
FMD220120X10	1,2	4	1,15	10	1,8	50	23,40



BALL NOSE

	FMD35						
	TOL -0,015	TOL h6					€
	D1 mm	D2 mm	D3 mm	L3 mm	L2 mm	L1 mm	
FMD350050X04	0,5	4	0,48	4	0,7	50	41,86
FMD350050X06	0,5	4	0,48	6	0,7	50	41,86
FMD350060X04	0,6	4	0,57	4	0,9	50	41,86
FMD350060X06	0,6	4	0,57	6	0,9	50	41,86
FMD350060X08	0,6	4	0,57	8	0,9	50	41,86
FMD350080X06	0,8	4	0,76	6	1,2	50	41,86
FMD350080X08	0,8	4	0,76	8	1,2	50	41,86
FMD350080X10	0,8	4	0,76	10	1,2	50	41,86
FMD350120X06	1,2	4	1,15	6	1,8	50	24,44
FMD350120X08	1,2	4	1,15	8	1,8	50	24,44
FMD350120X10	1,2	4	1,15	10	1,8	50	24,44



SOLID CARBIDE END MILLS

NEW
Ref. FMD22
Ref. FMD44
Ref. FMD35

GENERAL PURPOSE MICRO

SOLID CARBIDE



STRAIGHT

TiAlN



Ø 1-5 mm

Micro Grain CARBIDE



44 HRc

2Z 4Z



MATERIAL COATING QUALITY							FMD22	FMD44	FMD35	
							CARBIDE	CARBIDE	CARBIDE	
							TiAlN	TiAlN	TiAlN	
							★★	★★★	★★	
							2Z	4Z	2Z	
							€	€	€	
D1 mm	D2 mm	D3 mm	L3 mm	L2 mm	L1 mm					
1,0	6	0,95	5	1,5	57	FMD220100X05	32,07	FMD440100X05	FMD350100X05	32,85
1,0	6	0,95	8	1,5	57	FMD220100X08	32,07	FMD440100X08	FMD350100X08	33,80
1,0	6	0,95	10	1,5	57	FMD220100X10	32,07	FMD440100X10	FMD350100X10	33,80
1,0	6	0,95	12	1,5	65	FMD220100X12	33,80	FMD440100X12	FMD350100X12	35,36
1,0	6	0,95	15	1,5	65	FMD220100X15	33,80	FMD440100X15	FMD350100X15	35,36
1,0	6	0,95	20	1,5	65	FMD220100X20	33,80	FMD440100X20	FMD350100X20	35,36
1,5	6	1,42	5	2,0	57	FMD220150X05	32,07	FMD440150X05	FMD350150X05	33,80
1,5	6	1,42	8	2,0	57	FMD220150X08	32,07	FMD440150X08	FMD350150X08	33,80
1,5	6	1,42	10	2,0	57	FMD220150X10	32,07	FMD440150X10	FMD350150X10	33,80
1,5	6	1,42	12	2,0	65	FMD220150X12	33,80	FMD440150x12	FMD350150X12	35,36
1,5	6	1,42	15	2,0	65	FMD220150X15	33,80	FMD440150X15	FMD350150X15	35,36
1,5	6	1,42	20	2,0	65	FMD220150X20	33,80	FMD440150X20	FMD350150X20	35,36
1,5	6	1,42	25	2,0	65	FMD220150X25	33,80	FMD440150X25	FMD350150X25	-
2,0	6	1,92	6	3,0	57	FMD220200X06	32,07	FMD440200X06	FMD350200X06	33,80
2,0	6	1,92	8	3,0	57	FMD220200X08	32,07	FMD440200X08	FMD350200X08	33,80
2,0	6	1,92	10	3,0	57	FMD220200X10	32,07	FMD440200X10	FMD350200X10	33,80
2,0	6	1,92	12	3,0	60	FMD220200X12	32,93	FMD440200X12	FMD350200X12	33,80
2,0	6	1,92	14	3,0	65	FMD220200X14	33,80	FMD440200X14	FMD350200X14	33,80
2,0	6	1,92	16	3,0	65	FMD220200X16	33,80	FMD440200X16	FMD350200X16	34,63
2,0	6	1,92	20	3,0	65	FMD220200X20	33,80	FMD440200X20	FMD350200X20	34,63
2,0	6	1,92	25	3,0	65	FMD220200X25	33,80	FMD440200X25	FMD350200X25	34,63
2,0	6	1,92	30	3,0	80	FMD220200X30	41,08	FMD440200X30	FMD350200X30	42,55
2,0	6	1,92	35	2,0	80	FMD220200X35	41,08	FMD440200X35	FMD350200X35	42,55
2,0	6	1,92	40	3,0	80	FMD220200X40	41,08	FMD440200X40	FMD350200X40	42,90
2,0	6	1,92	50	3,0	100	FMD220200X50	44,20	FMD440200X50	FMD350200X50	46,77
2,5	6	2,40	10	4,0	57	FMD220250X10	32,07	FMD440250X10	FMD350250X10	-
2,5	6	2,40	16	4,0	65	FMD220250X16	33,80	FMD440250X16	FMD350250X16	-
2,5	6	2,40	20	4,0	65	FMD220250X20	33,80	FMD440250X20	FMD350250X20	34,63
2,5	6	2,40	30	4,0	80	FMD220250X30	41,08	FMD440250X30	FMD350250X30	42,90
2,5	6	2,40	40	4,0	80	FMD220250X40	41,08	FMD440250X40	FMD350250X40	42,90
3,0	6	2,90	9	5,0	57	FMD220300X09	32,07	FMD440300X09	FMD350300X09	34,63
3,0	6	2,90	12	5,0	60	FMD220300X12	32,93	FMD440300X12	FMD350300X12	34,63
3,0	6	2,90	15	5,0	65	FMD220300X15	33,80	FMD440300X15	FMD350300X15	34,63
3,0	6	2,90	20	5,0	65	FMD220300X20	33,80	FMD440300X20	FMD350300X20	34,63
3,0	6	2,90	25	5,0	65	FMD220300X25	33,80	FMD440300X25	FMD350300X25	35,36
3,0	6	2,90	30	5,0	80	FMD220300X30	41,08	FMD440300X30	FMD350300X30	42,90
3,0	6	2,90	35	5,0	80	FMD220300X35	41,08	FMD440300X35	FMD350300X35	42,90
3,0	6	2,90	40	5,0	80	FMD220300X40	41,08	FMD440300X40	FMD350300X40	42,90
3,0	6	2,90	50	5,0	100	FMD220300X50	44,20	FMD440300X50	FMD350300X50	46,77
4,0	6	3,90	10	6,0	57	FMD220400X10	32,07	FMD440400X10	FMD350400X10	33,80
4,0	6	3,90	12	6,0	60	FMD220400X12	32,93	FMD440400X12	FMD350400X12	34,63
4,0	6	3,90	16	6,0	65	FMD220400X16	33,80	FMD440400X16	FMD350400X16	34,63
4,0	6	3,90	20	6,0	65	FMD220400X20	33,80	FMD440400X20	FMD350400X20	34,63
4,0	6	3,90	25	6,0	65	FMD220400X25	33,80	FMD440400X25	FMD350400X25	35,36
4,0	6	3,90	30	6,0	80	FMD220400X30	41,08	FMD440400X30	FMD350400X30	42,90
4,0	6	3,90	35	6,0	80	FMD220400X35	41,08	FMD440400X35	FMD350400X35	42,90
4,0	6	3,90	40	6,0	80	FMD220400X40	41,08	FMD440400X40	FMD350400X40	42,90
4,0	6	3,90	50	6,0	100	FMD220400X50	44,20	FMD440400X50	FMD350400X50	46,77
5,0	6	4,80	12	7,0	60	FMD220500X12	32,93	FMD440500X12	FMD350500X12	-
5,0	6	4,80	20	7,0	65	FMD220500X20	33,80	FMD440500X20	FMD350500X20	34,63
5,0	6	4,80	30	7,0	80	FMD220500X30	41,08	FMD440500X30	FMD350500X30	42,90
5,0	6	4,80	40	7,0	80	FMD220500X40	41,08	FMD440500X40	FMD350500X40	42,90
5,0	6	4,80	50	7,0	100	FMD220500X50	44,20	FMD440500X50	FMD350500X50	46,77

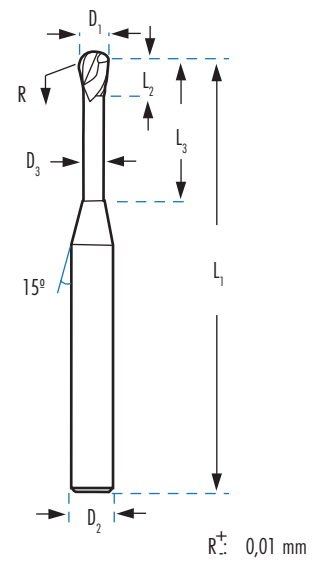

End mills

Pink

SOLID CARBIDE MEDIUM ROUGHING END MILLS

**GENERAL
PURPOSE**
**SOLID
CARBIDE**

STRAIGHT
TiAIN

SHORT SERIES

FMD3					
D ₁ mm	D ₂ mm	L ₁ mm	L ₂ mm	Z	€
TOL D ₁ +0 -0,05	TOL D ₂ h6				
6	6	50	16	4	35,85
8	8	60	19	4	48,58
10	10	75	22	4	74,76
12	12	75	26	4	102,61
16	16	92	32	4	233,43
20	20	100	38	4	349,80

LONG SERIES

FMD43					
D ₁ mm	D ₂ mm	L ₁ mm	L ₂ mm	Z	€
TOL D ₁ +0 -0,05	TOL D ₂ h6				
6	6	80	25	4	51,95
8	8	90	35	4	72,59
10	10	100	45	4	110,55
12	12	100	50	4	146,00
16	16	150	65	4	337,03
20	20	150	70	4	515,70

SOLID CARBIDE FINE AND COARSE ROUGHING END MILLS

**GENERAL
PURPOSE**
**SOLID
CARBIDE**

STRAIGHT

**GENERAL
PURPOSE**
**SOLID
CARBIDE**

STRAIGHT

FMD1					
D ₁ mm	D ₂ mm	L ₁ mm	L ₂ mm	Z	€
TOL D ₁ +0 -0,05	TOL D ₂ h6				
6	6	63	19	3	29,03 *
8	8	63	19	3	31,16 *
12	12	75	25	4	50,31 *
16	16	88	32	4	86,09 *
20	20	100	38	4	100,77 *

*Available until end of stock



FMD6					
D ₁ mm	D ₂ mm	L ₁ mm	L ₂ mm	Z	€
TOL D ₁ +0 -0,05	TOL D ₂ h6				
6	6	63	19	3	29,03 *
8	8	63	19	3	31,16 *
12	12	75	25	4	50,31 *
16	16	88	32	4	86,09 *
20	20	100	38	4	100,77 *

*Available until end of stock



SOLID CARBIDE 2 FLUTES END MILLS

Ref. FMG10

INOX **Ti** **55 HRc** **SOLID CARBIDE** **30°** **STRAIGHT** **TiAlN** **2 Z** **Micro Grain CARBIDE**

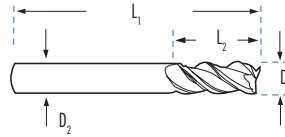

SHORT SERIES

R.P.M. & FEED						FMG10					
R.P.M. rev./min	FEED mm/min	R.P.M. rev./min	FEED mm/min	R.P.M. rev./min	FEED mm/min	D1 mm	TOL -0,03	TOL h6	L1 mm	L2 mm	€
							D1 mm	D2 mm			
21.500	170	12.900	101	10.750	84	FMG100100	1,0	6	40	2,5	25,99*
15.000	180	9.000	107	7.500	89	FMG100150	1,5	6	40	4,0	25,99*
11.560	190	7.560	120	6.300	90	FMG100200	2,0	6	50	6,0	38,62
8.920	210	5.560	140	4.620	120	FMG100300	3,0	6	50	8,0	38,62
7.560	300	4.620	180	3.880	150	FMG100400	4,0	6	50	11,0	38,62
6.300	320	3.780	190	3.160	160	FMG100500	5,0	6	50	12,0	38,62
5.560	350	3.360	220	2.840	180	FMG100600	6,0	6	50	12,0	38,62
4.880	385	2.940	220	2.470	180	FMG100700	7,0	8	60	16,0	35,78*
4.200	380	2.520	200	2.100	180	FMG100800	8,0	8	60	15,0	53,15
3.730	375	2.260	190	1.890	180	FMG100900	9,0	10	70	19,0	49,27*
3.260	330	2.000	160	1.680	160	FMG101000	10,0	10	72	20,0	73,20
2.740	280	1.680	130	1.360	130	FMG101200	12,0	12	75	24,0	103,39
2.470	265	1.520	125	1.210	125	FMG101400	14,0	14	85	26,0	119,86*
2.200	220	1.360	110	1.060	110	FMG101600	16,0	16	92	30,0	194,05
1.680	170	1.060	80	840	80	FMG102000	20,0	20	105	38,0	155,40*
1.360	130	840	70	680	60	FMG102500	25,0	25	120	45,0	202,30*



*Available until end of stock

SOLID CARBIDE 3 FLUTES END MILLS VARIABLE HELIX

Ref. FMD67

INOX **Ti** **55 HRc** **SOLID CARBIDE** **35°/38°** **STRAIGHT** **TiAlSiN** **3 Z** **Micro Grain CARBIDE**

SHORT SERIES

	FMD67				
	TOL e8	TOL h6			
	D1 mm	D2 mm	L1 mm	L2 mm	€
FMD670300	3	6	50	8	32,66
FMD670400	4	6	50	11	32,66
FMD670500	5	6	50	13	32,66
FMD670600	6	6	50	16	32,66
FMD670800	8	8	60	19	41,18
FMD671000	10	10	73	22	60,84
FMD671200	12	12	75	26	82,99
FMD671400	14	14	85	30	148,11
FMD671600	16	16	92	32	161,62
FMD672000	20	20	100	38	238,37



3 flute end-mill with center cutting, Variable Helix and TiAlSiN coating.
Its Variable Helix angle minimizes vibrations and, together with the TiAlSiN coating, offers spectacular machining performance.

End mills
Pink

SOLID CARBIDE 4 FLUTES END MILLS VARIABLE HELIX

Ref. FMG12

INOX **INOX AISI 316L** **Ti** **INC** **SOLID CARBIDE** **55 HRc** **TiAlSiN** **4 Z** **Micro Grain CARBIDE**

SHORT SERIES

R.P.M. & FEED						FMG12					
R.P.M. rev./min	FEED mm/min	R.P.M. rev./min	FEED mm/min	R.P.M. rev./min	FEED mm/min	TOL -0,03 D1 mm	TOL h6 D2 mm	L1 mm	L2 mm	€	
											<30 HRc
11.560	280	7.560	170	6.300	140	FMG120200	2,0	6	40	*6	21,98*
10.240	300	6.560	185	5.460	155	FMG120250	2,5	6	40	*8	21,98*
8.920	320	5.560	200	4.620	170	FMG120300	3,0	6	50	8	32,66
7.560	570	4.620	350	3.880	280	FMG120400	4,0	6	50	11	32,66
6.300	600	3.780	360	3.160	300	FMG120500	5,0	6	50	13	32,66
5.560	660	3.360	410	2.840	330	FMG120600	6,0	6	50	16	32,66
4.200	710	2.520	380	2.100	350	FMG120800	8,0	8	60	19	41,18
3.730	660	2.260	340	1.890	325	FMG120900	9,0	10	70	*19	40,95*
3.260	610	2.000	300	1.680	300	FMG121000	10,0	10	73	22	60,84
2.740	520	1.680	250	1.360	240	FMG121200	12,0	12	75	26	82,99
2.470	465	1.520	225	1.210	220	FMG121400	14,0	14	85	30	113,36
2.200	410	1.360	200	1.060	200	FMG121600	16,0	16	92	32	161,62
1.940	365	1.210	180	950	175	FMG121800	18,0	18	92	38	238,37
1.680	320	1.060	160	840	150	FMG122000	20,0	20	100	38	238,37



*Available until end of stock

End-mill for high hardness materials. 4 flute, center cutting and Variable Helix with TiAlSiN coating. Its Variable Helix angle minimizes vibrations and, together with the TiAlSiN coating, offers spectacular machining performance.

SOLID CARBIDE 4 FLUTES END MILLS VARIABLE HELIX

Ref. FMG83

INOX **INOX AISI 316L** **Ti** **INC** **SOLID CARBIDE** **X-45°** **TiAlSiN** **4 Z** **Micro Grain CARBIDE**

R.P.M. & FEED				FMG83							
R.P.M. rev./min	FEED mm/min	R.P.M. rev./min	FEED mm/min	TOL -0,03 D1 mm	TOL h6 D2 mm	L1 mm	L2 mm	L3 mm	X-45°	€	
											INOX AISI 316L
10.185	195	14.260	205	FMG830300	3,0	6	57	8	11	0,07	55,21
7.600	250	14.260	255	FMG830400	4,0	6	57	11	14	0,09	55,21
6.110	310	8.655	310	FMG830500	5,0	6	57	13	16	0,12	55,21
5.095	360	7.130	360	FMG830600	6,0	6	57	13	21	0,20	55,21
3.820	435	5.345	465	FMG830800	8,0	8	63	19	27	0,25	70,73
3.055	590	4.275	585	FMG831000	10,0	10	73	22	32	0,35	103,25
2.545	565	3.565	565	FMG831200	12,0	12	83	26	38	0,40	139,16
2.180	520	3.055	520	FMG831400	14,0	14	84	30	40	0,40	199,71
1.910	480	2.670	480	FMG831600	16,0	16	92	32	44	0,40	234,54
1.525	470	2.140	470	FMG832000	20,0	20	104	38	55	0,40	370,81



End-mill for high nickel content materials. 4 flute, center cutting with 45° chamfer on the cut, and Variable Helix with TiAlSiN coating. Its Variable Helix angle minimizes vibrations and, together with the TiAlSiN coating, offers spectacular machining performance..

MULTIPURPOSE END MILL

NEW
Ref. FMG80

**TOP
MULTI-
MATERIAL**



**SOLID
CARBIDE**



TiAlN

4 Z



**Micro Grain
CARBIDE**

SHORT SERIES

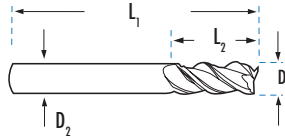

							FMG80
	TOL e8	TOL h6					
	D1 mm	D2 mm	D3 mm	L1 mm	L2 mm	L3 mm	€
FMG800300	3	6	8	20	0,05	57	36,66
FMG800400	4	6	11	20	0,05	57	36,66
FMG800500	5	6	13	21	0,07	57	36,66
FMG800600	6	6	13	21	0,10	57	36,66
FMG800800	8	8	19	27	0,15	63	44,81
FMG801000	10	10	22	32	0,15	73	65,00
FMG801200	12	12	26	38	0,25	83	92,25
FMG801400	14	14	30	40	0,30	84	117,26
FMG801600	16	16	32	44	0,35	92	164,49
FMG801800	20	20	38	55	0,35	104	242,32



4 flute end-mill with center cutting, Variable Helix and TiAlSiN coating.
Its Variable Helix angle minimizes vibrations and, together with the TiAlSiN coating, offers spectacular machining performance.

BALL NOSE END MILL FOR MOULD MAKING

NEW
Ref. FMG86

**MOULD
MAKING**



Ti



**SOLID
CARBIDE**



TiAlSiN

4 Z



**Micro Grain
CARBIDE**

SHORT SERIES

					FMG86
	TOL e8	TOL h6			
	D1 mm	D2 mm	L1 mm	L2 mm	€
FMG860600	6	6	8	50	33,28
FMG860600X80	6	6	8	80	43,65
FMG860600X100	6	6	8	100	48,07
FMG860600X150	6	6	8	150	63,34
FMG860800	8	8	10	60	42,61
FMG860800X100	8	8	10	100	60,39
FMG860800X150	8	8	10	150	81,52
FMG861000	10	10	13	72	62,99
FMG861000X100	10	10	13	100	86,79
FMG861000X150	10	10	13	150	115,72
FMG861000X200	10	10	13	200	162,52
FMG861200	12	12	15	75	86,27
FMG861200X100	12	12	15	100	121,56
FMG861200X150	12	12	15	150	169,26
FMG861200X200	12	12	15	200	198,41



SOLID CARBIDE 6 FLUTES END MILLS

Ref. FMG14

INOX **65 HRc** **Ti** **SOLID CARBIDE** **45°** **TiAlN** **6 Z**

Very hard materials.
Hardened steels

Micro Grain CARBIDE

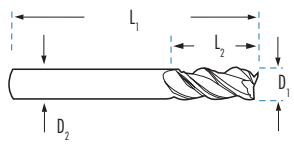

SHORT SERIES

						INOX		INC		FMG14				
R.P.M. rev./min	FEED mm/min	R.P.M. rev./min	FEED mm/min	R.P.M. rev./min	FEED mm/min	R.P.M. rev./min	FEED mm/min	R.P.M. rev./min	FEED mm/min	TOL -0,03 D1 mm	TOL h6 D2 mm	L1 mm	L2 mm	€
8.900	2.670	5.760	1.555	4.850	1.310	2.100	370	FMG140300	4Z	3,0	3	38	8	24,53
7.560	2.260	4.800	1.440	4.100	1.230	1.800	325	FMG140400	4Z	4,0	4	50	11	27,14
6.300	2.090	4.050	1.215	3.700	1.180	1.580	300	FMG140500	4Z	5,0	5	50	13	34,32
5.560	2.000	3.880	1.370	3.370	1.100	1.350	280	FMG140600		6,0	6	50	16	35,21
4.200	2.000	2.940	1.370	2.490	1.100	1.000	280	FMG140800		8,0	8	60	19	49,25
3.360	2.000	2.320	1.370	1.920	1.100	440	280	FMG141000		10,0	10	75	22	68,69
2.840	1.680	2.000	1.160	1.610	1.000	400	250	FMG141200		12,0	12	75	26	100,58
2.470	1.470	1.740	1.020	1.380	885	355	220	FMG141400		14,0	14	90	32	129,82
2.100	1.260	1.480	880	1.160	770	310	190	FMG141600		16,0	16	100	32	177,13
1.890	1.130	1.320	785	1.030	695	280	170	FMG141800		18,0	18	100	38	205,60
1.680	1.010	1.160	690	900	920	250	155	FMG142000		20,0	20	100	38	256,50
1.500	900	1.100	600	850	540	220	135	FMG142500		25,0	25	100	38	437,21



LONG SERIES

						INOX		INC		FMG25				
R.P.M. rev./min	FEED mm/min	R.P.M. rev./min	FEED mm/min	R.P.M. rev./min	FEED mm/min	R.P.M. rev./min	FEED mm/min	R.P.M. rev./min	FEED mm/min	TOL -0,03 D1 mm	TOL h6 D2 mm	L1 mm	L2 mm	€
8.900	2.670	5.760	1.555	4.850	1.310	2.100	370	FMG250300	4Z	3,0	3	60	15	24,18
7.560	2.260	4.800	1.440	4.100	1.230	1.800	325	FMG250400	4Z	4,0	4	80	20	27,25
6.300	2.090	4.050	1.215	3.700	1.180	1.580	300	FMG250500	4Z	5,0	5	80	25	31,29
5.560	2.000	3.880	1.370	3.370	1.100	1.350	280	FMG250600		6,0	6	80	25	37,94
4.200	2.000	2.940	1.370	2.490	1.100	1.000	280	FMG250800		8,0	8	90	35	55,41
3.360	2.000	2.320	1.370	1.920	1.100	440	280	FMG251000		10,0	10	100	45	75,00
2.840	1.680	2.000	1.160	1.610	1.000	400	250	FMG251200		12,0	12	100	50	107,15
2.840	1.680	2.000	1.160	1.610	1.000	400	250	FMG251200X125		12,0	12	125	70	132,67
2.470	1.470	1.740	1.020	1.380	885	355	220	FMG251400		14,0	14	150	65	145,65
2.100	1.260	1.480	880	1.160	770	310	190	FMG251600		16,0	16	150	65	187,15
2.100	1.260	1.480	880	1.160	770	310	190	FMG251600X165		16,0	16	165	100	213,60
1.680	1.010	1.160	690	900	920	250	155	FMG252000		20,0	20	150	70	276,78
1.680	1.010	1.160	690	900	920	250	155	FMG252000X165		20,0	20	165	100	319,26
1.680	1.010	1.160	690	900	920	250	155	FMG252000X200		20,0	20	200	135	408,06
1.500	900	1.100	600	850	540	220	135	FMG252500		25,0	25	150	75	532,10
1.500	900	1.100	600	850	540	220	135	FMG252500X165		25,0	25	165	100	616,06
1.500	900	1.100	600	850	540	220	135	FMG252500X200		25,0	25	200	140	690,82
								FMG253200		32,0	32	165	100	863,55
								FMG253200X210		32,0	32	210	150	1.036,13



SOLID CARBIDE 2 & 3 FLUTES END MILLS

Al
Cu
PVC
45° N
STRAIGHT
2Z
Ref. FMD59
3Z
Ref. FMD33
Micro Grain CARBIDE

SHORT SERIES

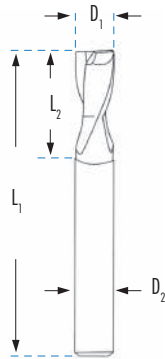

R.P.M. & FEED							FMD59	FMD33
Al			TOL -0,05	TOL h6			2Z	3Z
R.P.M rev./min.	FEED 1 mm/min	FEED 2 mm/min	D1 mm	D2 mm	L1 mm	L2 mm	€	€
10.000	700	900	3,0	6,0	50	8	FMD590300 27,60	FMD330300 27,60
10.000	900	1.100	4,0	6,0	50	11	FMD590400 29,90	FMD330400 29,90
10.000	1.000	1.300	5,0	6,0	50	13	FMD590500 30,89	FMD330500 30,89
10.000	1.200	1.500	6,0	6,0	50	16	FMD590600 35,07	FMD330600 35,07
8.000	1.400	1.800	8,0	8,0	60	19	FMD590800 49,97	FMD330800 49,97
8.000	1.700	2.100	10,0	10,0	72	25	FMD591000 73,47	FMD331000 73,47
8.000	2.100	2.600	12,0	12,0	75	30	FMD591200 97,07	FMD331200 97,07
6.000	1.800	2.200	14,0	14,0	84	35	FMD591400 136,23	FMD331400 136,23
6.000	1.900	2.400	16,0	16,0	92	40	FMD591600 172,80	FMD331600 172,80
4.000	1.600	1.900	20,0	20,0	100	45	FMD592000 284,99	FMD332000 284,99

TOLERANCES ACCORDING TO DIN 7160 & 7161

Tolerance range in μm / Nominal diameter in mm

	1 - 3	3 - 6	6 - 10	10 - 18	18 - 30
TOL	0	0	0	0	0
h10	- 40	- 48	- 58	- 70	- 84
TOL	0	0	0	0	0
h6	- 6	- 8	- 9	- 11	- 13

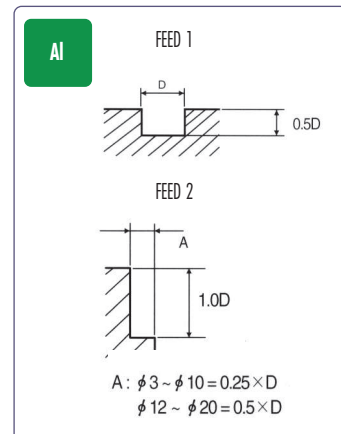

End mills

Pink

End mills
Pink

SOLID CARBIDE 2 & 3 FLUTES END MILLS

NEW **Al** **Cu** **PVC** **45° N** **STRAIGHT** **2Z** Ref. FMD69 **3Z** Ref. FMD23 **Micro Grain CARBIDE**

LONG SERIES

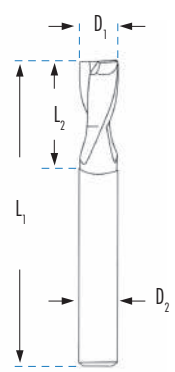

R.P.M. & FEED							FMD69		FMD23	
Al			TOL -0,05	TOL h6			2Z		3Z	
R.P.M rev./min.	FEED 1 mm/min	FEED 2 mm/min	D1 mm	D2 mm	L1 mm	L2 mm	€		€	
10.000	1.200	1.500	6,0	6,0	80	25	FMD690600	40,33	FMD230600	40,33
8.000	1.400	1.800	8,0	8,0	90	35	FMD690800	57,47	FMD230800	57,47
8.000	1.700	2.100	10,0	10,0	100	45	FMD691000	84,49	FMD231000	84,49
8.000	2.100	2.600	12,0	12,0	100	50	FMD691200	111,63	FMD231200	111,63
6.000	1.800	2.200	14,0	14,0	165	65	FMD691400	156,66	FMD231400	156,66
6.000	1.900	2.400	16,0	16,0	150	65	FMD691600	198,72	FMD231600	198,72
4.000	1.600	1.900	20,0	20,0	150	70	FMD692000	327,74	FMD232000	327,74

TOLERANCES ACCORDING TO DIN 7160 & 7161
Tolerance range in μm / Nominal diameter in mm

	1 - 3	3 - 6	6 - 10	10 - 18	18 - 30
TOL	0	0	0	0	0
h10	- 40	- 48	- 58	- 70	- 84
TOL	0	0	0	0	0
h6	- 6	- 8	- 9	- 11	- 13

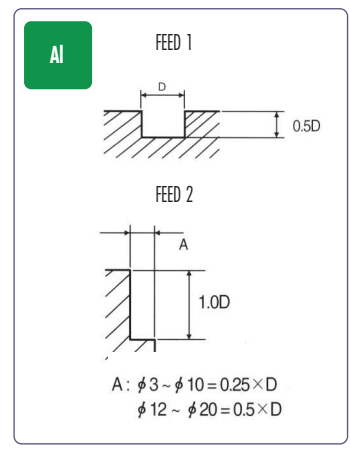

SOLID CARBIDE 2 FLUTES BALL NOSE END MILLS



Ref. FMD93
Ref. FMD94

**Micro Grain
CARBIDE**

End mills

Pink

SHORT SERIES

R.P.M. & FEED		
AI		
R.P.M. rev./min.	FEED 1 mm/min	FEED 2 mm/min
10.000	700	900
10.000	900	1.100
10.000	1.000	1.300
10.000	1.200	1.500
8.000	1.400	1.800
8.000	1.700	2.100
8.000	2.100	2.600
6.000	1.800	2.200
6.000	1.900	2.400
4.000	1.600	1.900

							FMD93	
TOL -0,05	TOL h6						2Z	€
D1 mm	D2 mm	L1 mm	L2 mm					
3,0	6,0	50	6	FMD930300				25,20
4,0	6,0	50	8	FMD930400				28,72
5,0	6,0	50	10	FMD930500				30,38
6,0	6,0	50	12	FMD930600				35,75
8,0	8,0	60	15	FMD930800				44,13
10,0	10,0	72	20	FMD931000				66,32
12,0	12,0	75	24	FMD931200				82,39
14,0	14,0	83	26	FMD931400				121,97
16,0	16,0	92	30	FMD931600				154,32
20,0	20,0	100	40	FMD932000				237,86

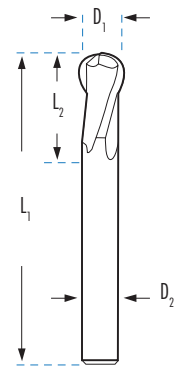

LONG SERIES

R.P.M. & FEED		
AI		
R.P.M. rev./min.	FEED 1 mm/min	FEED 2 mm/min
10.000	1.200	1.500
8.000	1.400	1.800
8.000	1.700	2.100
8.000	2.100	2.600
6.000	1.900	2.400
4.000	1.600	1.900

							FMD94	
TOL -0,05	TOL h6						2Z	€
D1 mm	D2 mm	D3 mm	L3 mm	L1 mm	L2 mm			
6,0	6,0	5,5	35	80	12	FMD940600		42,33
8,0	8,0	7,5	35	90	15	FMD940800		47,06
10,0	10,0	9,5	45	100	20	FMD941000		75,00
12,0	12,0	11,5	50	100	24	FMD941200		94,47
16,0	16,0	15,5	92	150	30	FMD941600		185,21
20,0	20,0	19,5	92	150	40	FMD942000		270,23

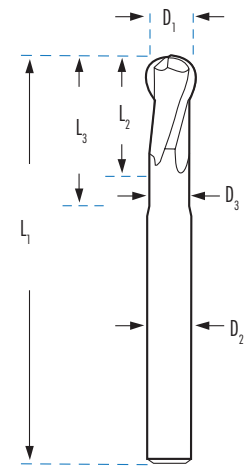

SOLID CARBIDE 3 TO 4 FLUTES END MILLS
INOX

Ti
INC
**SOLID
CARBIDE**

WELDON
TiAIN
3-4 Z

**Micro Grain
CARBIDE**

Ref. FMG13

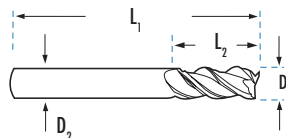
SHORT SERIES

R.P.M. & FEED								FMG13						
R.P.M. rev./min	FEED mm/min	R.P.M. rev./min	FEED mm/min	INOX		INC		TOL -0,03	TOL h6	L1 mm	L2 mm	Z	€	
				R.P.M. rev./min	FEED mm/min	R.P.M. rev./min	FEED mm/min	D1 mm	D2 mm					
4.200	310	2.520	180	2.100	160	920	40	FMG130800	8,0	8	60	19	3	30,99*
3.260	310	2.000	140	1.680	140	740	40	FMG131000	10,0	10	70	22	3	45,78*
2.740	250	1.680	120	1.370	120	620	30	FMG131200	12,0	12	75	25	3	62,74*
2.200	200	1.360	100	1.050	100	460	25	FMG131600	16,0	16	90	32	3	103,96*
1.940	175	1.210	85	950	85	410	20	FMG131800	18,0	18	90	32	3	121,54*
1.680	150	1.060	70	840	70	350	20	FMG132000	20,0	20	100	28	4	137,83*
1.360	115	840	60	670	60	300	15	FMG132500	25,0	25	120	45	4	220,44*

*Available until end of stock



TOLERANCES ACCORDING TO DIN 7160 & 7161

Tolerance range in μm / Nominal diameter in mm					
	1 - 3	3 - 6	6 - 10	10 - 18	18 - 30
TOL e8	- 14 - 28	- 20 - 38	- 25 - 47	- 32 - 59	- 40 - 73
TOL h6	0 - 6	0 - 8	0 - 9	0 - 11	0 - 13

SOLID CARBIDE 3 TO 5 FLUTES FINE ROUGHING END MILLS



Ref. FMG15
Ref. FMG16



Ti

INC

SOLID
CARBIDE



WELDON

TiAIN



Micro Grain
CARBIDE

End mills
Pink

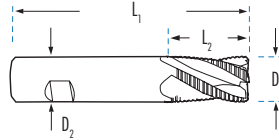

SHORT SERIES

R.P.M. & FEED								FMG15						
				INOX		INC		TOL h10	TOL h6					
R.P.M. rev./min	FEED mm/min	R.P.M. rev./min	FEED mm/min	R.P.M. rev./min	FEED mm/min	R.P.M. rev./min	FEED mm/min	D1 mm	D2 mm	L1 mm	L2 mm	Z	€	
15.600	2.320	12.400	840	8.400	570	2.400	190	FMG150600	6,0	6	54	7	3	23,07*
13.600	2.320	10.800	840	7.350	570	2.100	190	FMG150700	7,0	8	58	8	3	26,96*
11.600	2.320	9.200	840	6.300	570	1.800	190	FMG150800	8,0	8	58	9	3	26,96*
10.400	2.320	8.400	840	5.700	570	1.550	190	FMG150900	9,0	10	66	13	4	40,20*
9.200	2.320	7.600	840	5.100	570	1.300	190	FMG151000	10,0	10	66	14	4	40,20*
8.000	2.400	6.000	800	4.200	570	1.200	190	FMG151200	12,0	12	73	16	4	51,57*
6.800	2.400	5.200	840	3.600	570	900	130	FMG151400	14,0	14	75	18	4	62,55*
6.000	2.400	4.800	760	3.300	510	800	110	FMG151600	16,0	16	82	22	4	83,93*
4.800	2.160	3.600	560	2.400	360	660	100	FMG152000	20,0	20	92	26	4	121,49*
4.300	2.150	3.200	620	2.160	410	600	100	FMG152500	25,0	25	110	25	5	189,26*

*Available until end of stock



LONG SERIES

R.P.M. & FEED								FMG16						
				INOX		INC		TOL h10	TOL h6					
R.P.M. rev./min	FEED mm/min	R.P.M. rev./min	FEED mm/min	R.P.M. rev./min	FEED mm/min	R.P.M. rev./min	FEED mm/min	D1 mm	D2 mm	L1 mm	L2 mm	Z	€	
13.600	2.320	10.800	840	7.350	570	2.100	190	FMG160700	7,0	8	63	16	3	28,97*
11.600	2.320	9.200	840	6.300	570	1.800	190	FMG160800	8,0	8	63	16	3	28,97*
9.200	2.320	7.600	840	5.100	570	1.300	190	FMG161000	10,0	10	72	22	4	43,21*
6.800	2.400	5.200	840	3.600	570	900	130	FMG161400	14,0	14	83	26	4	67,24*
6.000	2.400	4.800	760	3.300	510	800	110	FMG161600	16,0	16	92	32	4	90,23*
4.800	2.160	3.600	560	2.400	360	660	100	FMG162000	20,0	20	104	38	4	130,63*
4.300	2.150	3.200	620	2.160	410	600	100	FMG162500	25,0	25	121	45	5	203,50*

*Available until end of stock



TOLERANCES ACCORDING TO DIN 7160 & 7161

Tolerance range in μm / Nominal diameter in mm					
	1 - 3	3 - 6	6 - 10	10 - 18	18 - 30
TOL e8	0	0	0	0	0
	- 40	- 48	- 58	- 70	- 84
TOL h6	0	0	0	0	0
	- 6	- 8	- 9	- 11	- 13

End mills
Pink

SOLID CARBIDE 4 TO 6 FLUTES FINE ROUGHING END MILLS



 Ref. FMG17
 







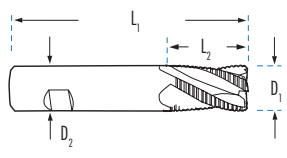



SHORT SERIES

R.P.M. & FEED								FMG17						
R.P.M. rev./min	FEED mm/min	R.P.M. rev./min	FEED mm/min	INOX		INC		TOL h10	TOL h6	L1 mm	L2 mm	Z	€	
				<30 HRc	30-45 HRc	D1 mm	D2 mm							
11.600	2.320	9.200	840	6.300	570	1.800	190	FMG170800	8,0	8	58	9	4	26,96*
8.000	2.400	6.000	800	4.200	570	1.200	190	FMG171200	12,0	12	73	16	4	51,57*
6.000	2.400	4.800	760	3.300	510	800	110	FMG171600	16,0	16	82	22	5	83,93*
4.800	2.160	3.600	560	2.400	360	660	100	FMG172000	20,0	20	92	26	6	107,99*

*Available until end of stock



CARBIDE 3 TO 6 FLUTES FINE ROUGHING END MILLS

 Ref. FMG18
 









LONG SERIES

R.P.M. & FEED								FMG18						
R.P.M. rev./min	FEED mm/min	R.P.M. rev./min	FEED mm/min	INOX		INC		TOL h10	TOL h6	L1 mm	L2 mm	Z	€	
				<30 HRc	30-45 HRc	D1 mm	D2 mm							
20.100	4.600	18.400	1.700	12.600	1.040	3.800	399	FMG180400	4,0	6	57	11	3	24,07*
15.600	2.320	12.400	840	8.400	570	2.400	190	FMG180600	6,0	6	57	16	4	24,07*
13.600	2.320	10.800	840	7.350	570	2.100	190	FMG180700	7,0	8	63	16	4	28,13*
11.600	2.320	9.200	840	6.300	570	1.800	190	FMG180800	8,0	8	63	16	4	28,13*
9.200	2.320	7.600	840	5.100	570	1.300	190	FMG181000	10,0	10	72	22	4	41,95*
6.800	2.400	5.200	840	3.600	570	900	130	FMG181400	14,0	14	83	26	5	65,28*
6.000	2.400	4.800	760	3.300	510	800	110	FMG181600	16,0	16	92	32	5	87,61*
4.800	2.160	3.600	560	2.400	360	660	100	FMG182000	20,0	20	104	38	6	140,91*
4.300	2.150	3.200	620	2.160	410	600	100	FMG182500	25,0	25	121	45	6	246,97*

*Available until end of stock



SOLID CARBIDE 4 TO 6 FLUTES FINE ROUGHING END MILLS

NF
INOX
Ref. FMG19
INC
45 HRc
SOLID CARBIDE
45°
WELDON
TiAlN
4-6 Z
Micro Grain CARBIDE

LONG SERIES

FMG19								
	TOL h10	TOL h6						
	D ₁ mm	D ₂ mm	D ₃ mm	L ₁ mm	L ₂ mm	L ₃ mm	Z	€
FMG190600	6,0	6	5,5	57	16	20	4	29,72*
FMG190800	8,0	8	7,5	63	16	26	4	34,74*
FMG191000	10,0	10	9,5	72	22	31	4	51,82*
FMG191200	12,0	12	11,5	83	26	37	4	66,49*
FMG191600	16,0	16	15,5	100	32	51	5	86,66*
FMG192000	20,0	20	19,2	110	38	59	6	139,31*

*Available until end of stock

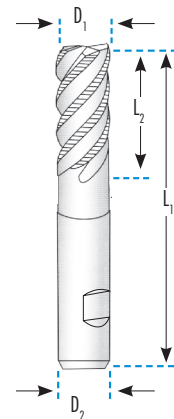

R.P.M. & FEED

R.P.M. rev./min	FEED 1 mm/min			R.P.M. rev./min	FEED 1 mm/min	INOX		INC	
		R.P.M. rev./min	FEED 1 mm/min			R.P.M. rev./min	FEED 1 mm/min	R.P.M. rev./min	FEED 1 mm/min
15.600	2.320	12.400	840	8.400	570	2.400	190		
11.600	2.320	9.200	840	6.300	570	1.800	190		
9.200	2.320	7.600	840	5.100	570	1.300	190		
8.000	2.400	6.000	800	4.200	570	1.200	190		
6.000	2.400	4.800	760	3.300	510	800	110		
4.800	2.160	3.600	560	2.400	360	660	100		

TOLERANCES ACCORDING TO DIN 7160 & 7161

Tolerance range in μm / Nominal diameter in mm					
	1 - 3	3 - 6	6 - 10	10 - 18	18 - 30
TOL	0	0	0	0	0
h10	- 40	- 48	- 58	- 70	- 84
TOL	0	0	0	0	0
h6	- 6	- 8	- 9	- 11	- 13

End mills

Pink

SOLID CARBIDE 2 FLUTES STUB CUT END MILLS



Ref. FMG01

SOLID CARBIDE



STRAIGHT

BLUE

2 Z



Micro Grain CARBIDE

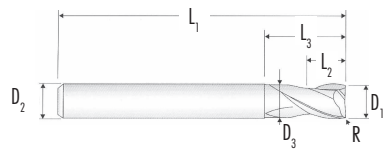

R.P.M. & FEED								FMG01									
R.P.M. rev./min.	FEED mm/min	R.P.M. rev./min.	FEED mm/min	R.P.M. rev./min.	FEED mm/min	R.P.M. rev./min.	FEED mm/min	Special TOL	TOL h6	D1 mm	D2 mm	D3 mm	L1 mm	L2 mm	L3 mm	R	€
25.500	360	20.500	215	16.000	135	12.500	88	FMG010100	1,0	3	-	40	1,5	-	0,1	17,54*	
21.500	390	17.500	240	13.500	150	11.000	102	FMG010150	1,5	3	-	40	2,2	-	0,1	17,54*	
11.500	420	9.500	260	7.500	160	6.400	115	FMG010300	3,0	6	2,9	45	4,0	7	0,1	23,24*	
10.150	430	8.350	270	6.550	165	5.575	118	FMG010350	3,5	6	3,3	45	5,0	9	0,1	23,24*	
8.800	440	7.200	270	5.600	170	4.750	118	FMG010400	4,0	6	3,8	45	5,0	9	0,1	23,24*	
8.550	470	6.800	280	5.350	175	4.600	125	FMG010450	4,5	6	4,3	45	6,0	10	0,1	23,24*	
6.900	480	5.300	280	4.200	180	3.700	130	FMG010600	6,0	6	5,8	50	7,0	14	0,2	23,24*	
4.100	415	3.200	240	2.550	155	2.200	112	FMG011000	10,0	10	9,7	75	12,0	25	0,2	43,92*	
3.500	415	2.650	240	2.100	155	1.860	112	FMG011200	12,0	12	11,7	75	15,0	30	0,3	60,56*	
2.600	365	2.000	210	1.600	135	1.400	98	FMG011600	16,0	16	15,7	90	18,0	38	0,3	100,97*	
2.050	335	1.600	295	1.300	125	1.100	88	FMG012000	20,0	20	19,7	100	24,0	45	0,3	133,56*	

*Available until end of stock



SOLID CARBIDE 4 FLUTES STUB CUT END MILLS



Ref. FMG04

SOLID CARBIDE



STRAIGHT

BLUE

4 Z



Micro Grain CARBIDE

R.P.M. & FEED								FMG04									
R.P.M. rev./min.	FEED mm/min	R.P.M. rev./min.	FEED mm/min	R.P.M. rev./min.	FEED mm/min	R.P.M. rev./min.	FEED mm/min	Special TOL	TOL h6	D1 mm	D2 mm	D3 mm	L1 mm	L2 mm	L3 mm	R	€
25.500	710	20.500	430	16.000	270	12.500	175	FMG040100	1,0	3	-	40	1,5	-	0,1	17,54*	
21.500	775	17.500	475	13.500	295	11.000	200	FMG040150	1,5	3	-	40	2,2	-	0,1	17,54*	
17.500	840	14.500	520	11.000	320	9.500	230	FMG040200	2,0	3	1,9	40	3,0	6	0,1	15,91*	
11.500	840	9.500	520	7.500	320	6.400	230	FMG040300	3,0	6	2,9	45	4,0	7	0,1	23,24*	
10.150	860	8.350	530	6.550	328	5.575	240	FMG040350	3,5	6	3,3	45	5,0	9	0,1	23,24*	
8.800	880	7.200	540	5.600	335	4.750	240	FMG040400	4,0	6	3,8	45	5,0	9	0,1	23,24*	
8.550	940	6.800	560	5.350	353	4.600	255	FMG040450	4,5	6	4,3	45	6,0	10	0,1	23,24*	
6.900	950	5.300	560	4.200	350	3.700	260	FMG040600	6,0	6	5,8	50	7,0	14	0,2	23,24*	
4.100	840	3.200	480	2.550	310	2.200	220	FMG041000	10,0	10	9,7	75	12,0	25	0,2	43,92*	
3.500	840	2.650	480	2.100	300	1.860	220	FMG041200	12,0	12	11,7	75	15,0	30	0,3	60,56*	
2.600	730	2.000	420	1.600	270	1.400	200	FMG041600	16,0	16	15,7	90	18,0	38	0,3	100,97*	
2.050	650	1.600	380	1.300	250	1.100	180	FMG042000	20,0	20	19,7	100	24,0	45	0,3	133,56*	

*Available until end of stock



SOLID CARBIDE 2 FLUTES STUB CUT END MILLS



Ref. FMG02

SOLID CARBIDE



STRAIGHT

BLUE

2 Z



Micro Grain CARBIDE

End mills

Pink

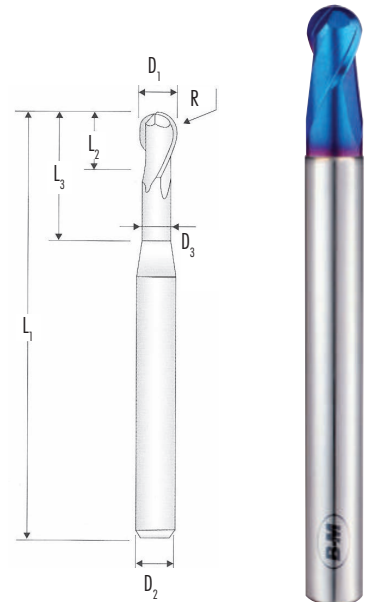

SHORT SERIES

R.P.M. & FEED

R.P.M rev./min.	50-55 HRc		55-60 HRc		60-65 HRc		65-70 HRc	
	R.P.M	FEED 1	R.P.M	FEED 1	R.P.M	FEED 1	R.P.M	FEED 1
57.000	4.000	54.000	3.400	51.000	2.700	48.000	2.300	
48.500	4.000	44.500	3.275	41.500	2.750	38.250	2.300	
40.000	4.000	35.000	3.150	32.000	2.800	28.500	2.300	
26.500	4.000	23.500	3.150	21.000	2.800	19.000	2.300	
15.000	3.750	13.500	3.050	11.500	2.550	10.500	2.100	
11.000	3.100	10.000	2.500	8.800	2.150	8.000	1.750	
9.000	2.700	8.000	2.150	7.000	1.850	6.500	1.550	
7.500	2.400	6.600	1.900	5.800	1.650	5.300	1.380	
5.600	1.900	5.000	1.550	4.400	1.250	4.000	1.050	
5.000	1.800	4.500	1.450	3.950	1.125	3.600	950	
4.000	1.600	3.600	1.275	3.150	900	2.875	750	
3.600	1.500	3.200	1.200	2.800	800	2.550	660	
-	-	-	-	-	-	-	-	

FMG02

	Special TOL	TOL h6		TOL R				€	
		D1 mm	D2 mm	D3 mm	L1 mm	L2 mm	L3 mm		R
FMG020100		1,0	4	0,95	50	1,0	2,2	0,5	28,92*
FMG020150		1,5	4	1,40	50	1,5	3,0	0,8	28,92*
FMG020200		2,0	4	1,90	50	2,0	4,0	1,0	27,46*
FMG020300		3,0	6	2,90	60	3,0	6,0	1,5	27,46*
FMG020500		5,0	6	4,90	80	5,0	10,0	2,5	29,55*
FMG020600		6,0	6	5,90	90	6,0	12,0	3,0	31,69*
FMG020800		8,0	8	7,90	100	8,0	16,0	4,0	49,45*
FMG021000		10,0	10	9,90	100	10,0	20,0	5,0	81,55*
FMG021200		12,0	12	11,90	110	12,0	24,0	6,0	104,68*
FMG021400		14,0	14	13,80	110	14,0	28,0	7,0	105,90*
FMG021800		18,0	18	17,80	140	18,0	36,0	9,0	150,96*
FMG022000		20,0	20	19,80	160	20,0	40,0	10,0	213,94*
FMG022500		25,0	25	24,80	180	25,0	50,0	12,5	346,80*

*Available until end of stock

TOLERANCES ACCORDING TO DIN 7160 & 7161

Tolerance range in μm / Nominal diameter in mm

	1 - 3	3 - 6	6 - 10	10 - 18	18 - 30
Special TOL	0	0	0	0	0
	- 12	- 12	- 15	- 15	- 15
TOL h6	0	0	0	0	0
	- 6	- 8	- 9	- 11	- 13
TOL R	0	0	0	0	0
	- 5	- 10	- 10	- 10	- 10

End mills
Pink

SOLID CARBIDE 6 FLUTES END MILLS

70 HRc

Ref. FMG06

SOLID CARBIDE

45°

STRAIGHT

BLUE

6 Z

Micro Grain
CARBIDE

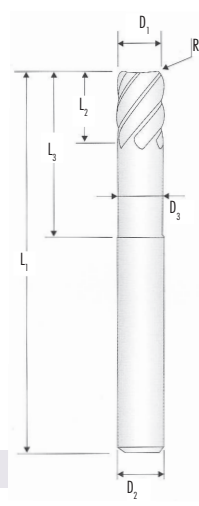

SHORT SERIES

R.P.M. & FEED							
50-55 HRc		55-60 HRc		60-65 HRc		65-70 HRc	
R.P.M	FEED 1	R.P.M	FEED 1	R.P.M	FEED 1	R.P.M	FEED 1
rev./min.	mm/min	rev./min.	mm/min	rev./min.	mm/min	rev./min.	mm/min
12.000	4.600	10.000	3.100	8.000	2.000	6.000	1.400
9.500	4.100	8.000	2.900	6.400	1.800	4.800	1.300
8.000	3.800	6.600	2.500	5.300	1.600	4.000	1.150

	Special TOL		TOL h6					TOL R	€
	D1 mm	D2 mm	D3 mm	L1 mm	L2 mm	L3 mm	R		
FMG060800	8,0	8	7,65	60	8	24	0,5	39,65*	
FMG061000	10,0	10	9,65	70	10	30	1,0	61,85*	
FMG061200	12,0	12	11,60	75	12	30	1,0	73,88*	

*Available until end of stock

LONG SERIES

R.P.M. & FEED							
50-55 HRc		55-60 HRc		60-65 HRc		65-70 HRc	
R.P.M	FEED 1	R.P.M	FEED 1	R.P.M	FEED 1	R.P.M	FEED 1
rev./min.	mm/min	rev./min.	mm/min	rev./min.	mm/min	rev./min.	mm/min
16.000	4.900	13.500	3.300	10.500	2.100	8.000	1.450
12.000	4.600	10.000	3.100	8.000	2.000	6.000	1.400
9.500	4.100	8.000	2.900	6.400	1.800	4.800	1.300
8.000	3.800	6.600	2.500	5.300	1.600	4.000	1.150
8.000	3.800	6.600	2.500	5.300	1.600	4.000	1.150
6.000	3.400	5.000	2.300	4.000	1.250	3.000	870
6.000	3.400	5.000	2.300	4.000	1.250	3.000	870
4.800	3.200	4.000	2.100	3.200	1.020	2.400	690
4.800	3.200	4.000	2.100	3.200	1.020	2.400	690
4.800	3.200	4.000	2.100	3.200	1.020	2.400	690

	Special TOL	TOL h6				R	€
	D1 mm	D2 mm	L1 mm	L2 mm			
FMG070600	6,0	6	70	13	0,5	37,77*	
FMG070800	8,0	8	90	19	0,5	47,34*	
FMG071000	10,0	10	100	22	0,5	71,32*	
FMG071200	12,0	12	110	26	0,5	97,28*	
FMG071201	12,0	12	110	26	1,0	108,95*	
FMG071600	16,0	16	130	32	1,0	131,24*	
FMG071601	16,0	16	130	32	1,5	143,33*	
FMG072000	20,0	20	140	38	1,0	192,06*	
FMG072001	20,0	20	140	38	1,5	209,81*	
FMG072002	20,0	20	140	38	2,0	209,81*	

*Available until end of stock

TOLERANCES ACCORDING TO DIN 7160 & 7161					
Tolerance range in μm / Nominal diameter in mm					
	1 - 3	3 - 6	6 - 10	10 - 18	18 - 30
Special TOL	0	0	0	0	0
	- 12	- 12	- 15	- 15	- 15
TOL h6	0	0	0	0	0
	- 6	- 8	- 9	- 11	- 13

SOLID CARBIDE 2 FLUTES MINIATURE END MILLS



Ref. FMG09

SOLID CARBIDE



STRAIGHT

BLUE

2 Z



TOL D1
-0,012

TOL D2
h6

Micro Grain
CARBIDE

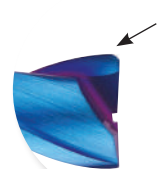
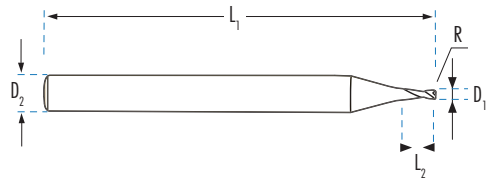

FMG09						
	D1 mm	D2 mm	L1 mm	L2 mm	R	€
FMG090040	0,40	6	50	0,60	-	63,50 *
FMG090050	0,50	6	50	0,70	0,05	55,24 *
FMG090060	0,60	6	50	0,90	0,05	53,14 *
FMG090080	0,80	6	50	1,20	0,05	48,97 *
FMG090100	1,00	6	50	1,50	0,10	46,93 *
FMG090120	1,20	6	50	1,80	0,10	46,93 *
FMG090150	1,50	6	50	2,20	0,15	46,93 *
FMG090200	2,00	6	50	2,20	0,15	42,53 *

*Available until end of stock



Ref. FMG08

SOLID CARBIDE



STRAIGHT

BLUE

2 Z



TOL D1
-0,012

TOL D2
h6

Micro Grain
CARBIDE

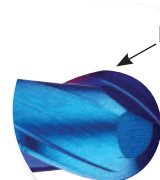
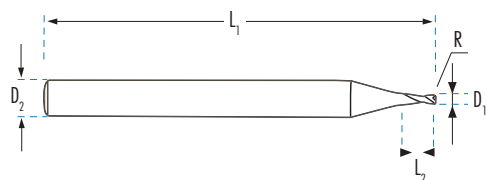

FMG08						
	D1 mm	D2 mm	L1 mm	L2 mm	R	€
FMG080040	0,40	6	50	0,40	0,20	68,68 *
FMG080050	0,50	6	50	0,50	0,25	63,40 *
FMG080060	0,60	6	50	0,60	0,30	58,13 *
FMG080080	0,80	6	50	0,80	0,40	47,41 *
FMG080100	1,00	6	50	1,00	0,50	44,64 *
FMG080120	1,20	6	50	1,20	0,60	44,64 *
FMG080150	1,50	6	50	1,50	0,75	44,64 *
FMG080200	2,00	6	50	2,00	1,00	40,45 *

*Available until end of stock



End mills

Pink

SPECIAL CARBIDE END MILLS FOR ALUCOBOND

CARBIDE TIPPED Ref. FFALUC	SOLID CARBIDE Ref. FFALUC...MDI
--------------------------------------	---

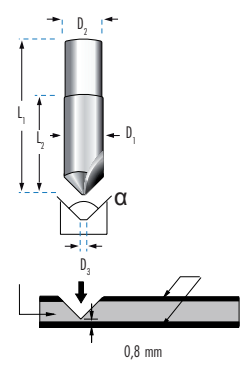
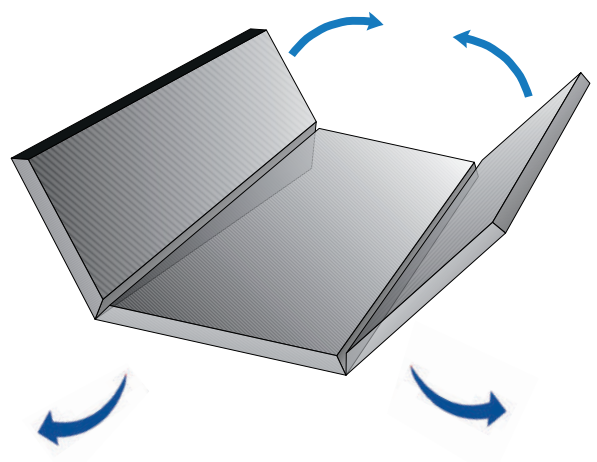
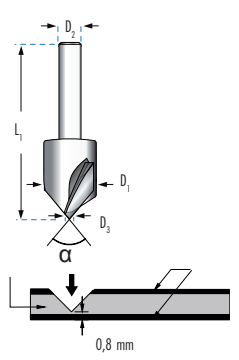

CARBIDE TIPPED

SOLID CARBIDE

FFALUC						
	D1 mm	D2 mm	D3 mm	L1 mm	α	€
FFALUC1600	16,00	8	2,5	55	90°	235,54
FFALUC1800	18,00	8	2,5	55	90°	248,06
FFALUC2000	20,00	8	2,5	55	90°	264,49
FFALUC1600-135	16,00	8	2,3	55	135°	235,54
FFALUC1800-135	18,00	8	2,3	55	135°	248,06
FFALUC2000-135	20,00	8	2,3	55	135°	264,49

FFALUC...MDI							
	D1 mm	D2 mm	D3 mm	L1 mm	L2 mm	α	€
FFALUC1400MDI	14,00	14	2,5	50	14	90°	140,90
FFALUC1600MDI	16,00	16	2,5	50	16	90°	160,35
FFALUC1800MDI	18,00	18	2,5	50	18	90°	184,97
FFALUC1400MDI-135	14,00	14	0,5	50	14	135°	140,90 *
FFALUC1600MDI-135	16,00	16	0,5	50	16	135°	160,35 *
FFALUC1800MDI-135	18,00	18	0,5	50	18	135°	184,97 *

*Available until end of stock



BLUE-MASTER[®]
by *CE/ESA*



SHELL MILLING CUTTERS

SIDE AND FACE MILLING CUTTERS CROSS TEETH



Ref. FF56

HSSCo

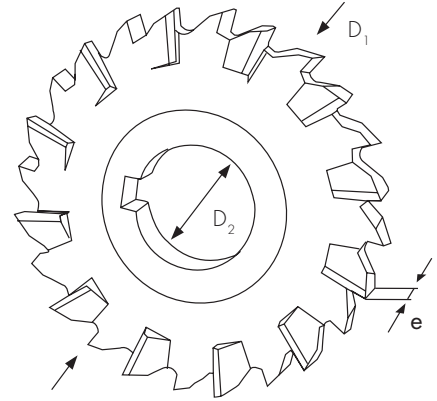
DIN
885A

FF56				
D1 mm	e mm	D2 mm	Z	€
50	4,0	16	12	105,51
50	5,0	16	12	105,51
50	6,0	16	12	122,26
50	8,0	16	12	119,07
50	10,0	16	12	131,11
63	1,6	22	16	225,97
63	2,0	22	16	200,06
63	2,5	22	16	204,24
63	3,0	22	16	209,84
63	4,0	22	12	121,74
63	5,0	22	12	121,74
63	6,0	22	12	125,18
63	8,0	22	12	136,42
63	10,0	22	12	146,79
63	12,0	22	12	156,73
63	14,0	22	12	168,81
63	16,0	22	12	177,69
63	18,0	22	12	212,30
80	1,6	27	20	225,86
80	2,0	27	20	219,38
80	2,5	27	20	223,04
80	3,0	27	20	218,61
80	4,0	27	20	261,53
80	5,0	27	14	165,39
80	6,0	27	14	169,29
80	8,0	27	14	178,66
80	10,0	27	14	191,20
80	12,0	27	14	204,67
80	14,0	27	14	218,86
80	16,0	27	14	223,91
80	18,0	27	14	240,19
80	20,0	27	14	264,10

FF56				
D1 mm	e mm	D2 mm	Z	€
100	1,6	32	24	270,18
100	2,0	32	24	268,72
100	2,5	32	24	268,46
100	3,0	32	24	260,64
100	4,0	32	24	281,00
100	5,0	32	24	297,89
100	6,0	32	16	232,49
100	8,0	32	16	237,39
100	10,0	32	16	246,11
100	12,0	32	16	265,06
100	14,0	32	16	291,82
100	16,0	32	16	306,08
100	18,0	32	16	337,40
100	20,0	32	16	337,40
100	22,0	32	16	378,21
100	25,0	32	16	411,41
125	1,6	32	16	341,68
125	2,0	32	16	328,64
125	2,5	32	16	336,81
125	3,0	32	16	345,01
125	4,0	32	16	369,62
125	5,0	32	16	395,65
125	6,0	32	16	405,42
125	8,0	32	18	366,68
125	10,0	32	18	376,25
125	12,0	32	18	390,51
125	14,0	32	18	424,08
125	16,0	32	18	450,31
125	18,0	32	18	476,31
125	20,0	32	18	506,77
125	22,0	32	18	577,03
125	25,0	32	18	582,62
125	28,0	32	18	636,80

FF56				
D1 mm	e mm	D2 mm	Z	€
160	2,0	40	30	549,95
160	2,5	40	30	529,44
160	3,0	40	30	539,61
160	4,0	40	30	570,19
160	5,0	40	30	603,81
160	6,0	40	30	648,33
160	8,0	40	30	739,99
160	10,0	40	22	607,78
160	12,0	40	22	607,78
160	14,0	40	22	604,80
160	16,0	40	22	661,90
160	18,0	40	22	697,44
160	20,0	40	22	715,92
160	22,0	40	22	786,91
160	25,0	40	22	852,66
160	28,0	40	22	937,29
160	32,0	40	22	1.002,15
200	12,0	40	24	927,11
200	14,0	40	24	936,18
200	16,0	40	24	964,48
200	18,0	40	24	1.011,95
200	20,0	40	24	1.082,29
200	22,0	40	24	1.085,85
200	25,0	40	24	1.259,55
200	28,0	40	24	1.299,37
200	32,0	40	24	1.620,51

SIDE AND FACE MILLING CUTTERS STRAIGHT TEETH



Ref. FF59

HSSCo

**DIN
885B**

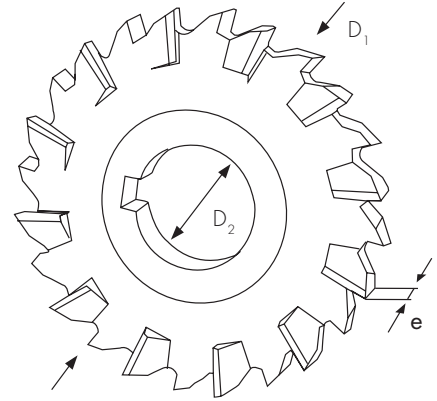

End mills

Pink

FF59				
D1 mm	e mm	D2 mm	Z	€
50	4	16	16	105,18
50	5	16	16	105,18
50	6	16	16	121,90
50	8	16	16	118,72
50	10	16	16	130,73
63	4	22	18	122,53
63	5	22	18	122,53
63	6	22	18	124,16
63	8	22	18	134,98
63	10	22	18	145,25
63	12	22	18	155,57
63	14	22	18	167,54
63	16	22	18	177,22
63	18	22	18	211,66
80	5	27	20	164,82
80	6	27	20	169,17
80	8	27	20	178,52
80	10	27	20	190,57
80	12	27	20	204,04
80	14	27	20	218,20
80	16	27	20	223,87
80	18	27	20	240,15
80	20	27	20	264,05

FF59				
D1 mm	e mm	D2 mm	Z	€
100	6	32	22	230,13
100	8	32	22	236,66
100	10	32	22	245,32
100	12	32	22	264,20
100	14	32	22	290,88
100	16	32	22	308,17
100	18	32	22	337,33
100	20	32	22	337,33
100	22	32	22	377,07
100	25	32	22	412,48
125	8	32	24	366,46
125	10	32	24	376,02
125	12	32	24	390,28
125	14	32	24	423,84
125	16	32	24	445,60
125	18	32	24	476,16
125	20	32	24	506,63
125	22	32	24	576,88
125	25	32	24	582,47
125	28	32	24	636,60

FF59				
D1 mm	e mm	D2 mm	Z	€
160	10	40	28	607,60
160	12	40	28	607,60
160	14	40	28	604,64
160	16	40	28	661,70
160	18	40	28	697,25
160	20	40	28	715,72
160	22	40	28	786,68
160	25	40	28	852,43
160	28	40	28	937,02
160	32	40	28	1.001,86
200	12	40	30	926,84
200	14	40	30	935,92
200	16	40	30	964,22
200	18	40	30	1.011,67
200	20	40	30	1.081,98
200	22	40	30	1.085,55
200	25	40	30	1.259,21
200	28	40	30	1.299,01
200	32	40	30	1.620,07

GEAR MILLING CUTTERS

End mills
Pink

HSS

Ref. 99RFM

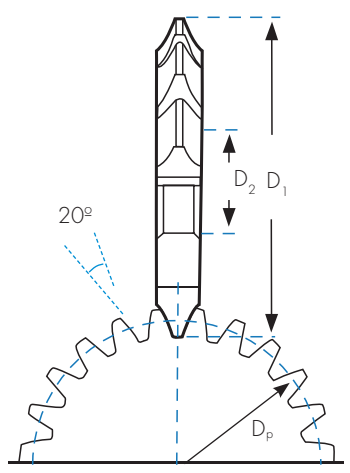

			99RFM
MILLING CUTTER UNIT	D1 mm	D2 mm	€
0,50	40	16	131,56
0,70	40	16	131,56
0,75	40	16	131,56
0,80	40	16	131,56
1,00	50	16	131,56
1,25	50	16	131,56
1,50	56	22	135,10
1,75	56	22	135,10
2,00	63	22	135,10
2,25	63	22	158,33
2,50	63	22	158,33
2,75	71	27	158,33
3,00	71	27	158,33
3,25	71	27	208,94
3,50	80	27	208,94
3,75	80	27	208,94
4,00	80	27	208,94
4,50	90	32	286,37
5,00	90	32	286,37
6,00	100	32	362,61
7,00	100	32	362,61

CUTTER N° / TEETH

N°1	N°2	N°3	N°4	N°5	N°6	N°7	N°8	Set
12-13	14-16	17-20	21-25	26-34	35-54	55-134	135-∞	12-∞

$$M = D_p / Z$$

$$M = P \times \pi$$

M=Module
Dp=Primitive diameter
Z=No of teeth
P=Pass (Tooth+Valley)

* Price depends on the n° of milling cutter unit independently of the n° of teeth.

MULTI-FLUTE SHELL END MILLS WITH DOUBLE DRIVING SLOT

Ref. FF87 **HSSCo** **DIN 1880** **FINISHING**

Ref. FF88 **HSSCo** **DIN 1880** **NR** **ROUGHING**

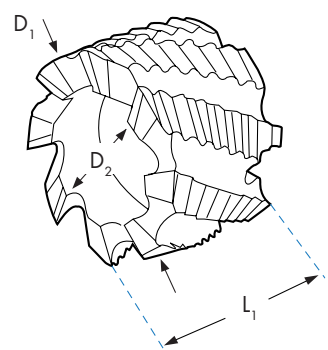
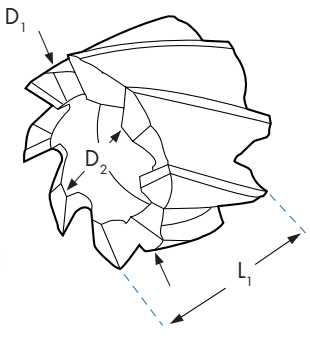

FF87				
D1 mm	D2 mm	L1 mm	Z	€
40	16	32	8	138,75
50	22	36	8	190,90
63	27	40	8	260,85
80	27	45	10	369,21
100	32	50	12	594,39
125	40	56	14	954,54
160	50	63	16	1.705,96

FF88				
D1 mm	D2 mm	L1 mm	Z	€
40	16	32	6	200,95
50	22	36	6	249,54
63	27	40	8	330,63
80	27	45	8	485,96
100	32	50	10	801,77
125	40	56	12	1.360,22
160	50	63	14	2.360,18

MULTI-FLUTE SHELL END MILLS WITH DOUBLE DRIVING SLOT



Ref. FF89

HSSCo

**DIN
884**



PLAIN

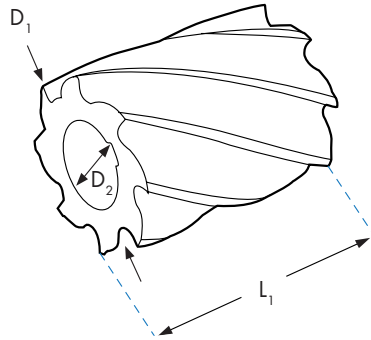
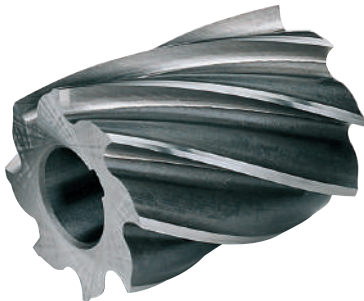

FF89				
D1 mm	D2 mm	L1 mm	Z	€
30	22	63	8	173,84*
50	22	80	8	259,14*
63	27	50	8	228,11*
63	27	70	8	277,53*
80	32	63	8	384,48*
100	40	70	10	598,18*

* Till end of stock

PLAIN MILLING CUTTERS WITH SHANK



Ref. FMF87

**HSSCo
8%**



FINISHING

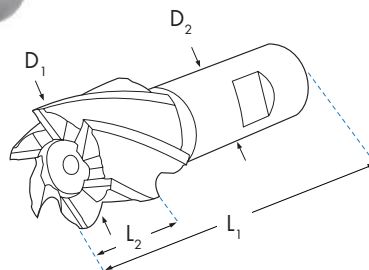

FMF87					
D1 mm	L2 mm	L1 mm	D2 mm	Z	€
30	30	90	20	6	202,26
35	30	90	20	6	232,12
40	32	95	25	8	289,30



Ref. FMF88

**HSSCo
8%**



ROUGHING

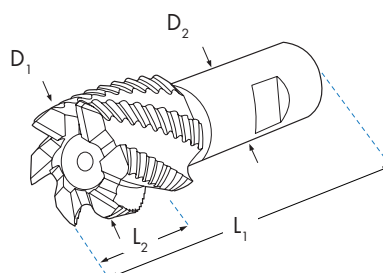

FMF88					
D1 mm	L2 mm	L1 mm	D2 mm	Z	€
30	30	90	20	6	233,82
35	30	90	20	6	299,55
40	32	95	25	8	366,95

HSSCo DOUBLE ANGLE MILLING CUTTERS

<p>Ref. FF77</p> <div style="display: flex; justify-content: space-around; align-items: center;"> <div style="border: 1px solid black; padding: 2px;">HSSCo</div> <div style="border: 1px solid black; padding: 2px;">DIN 847</div> <div style="border: 1px solid black; padding: 2px; text-align: center;">45° </div> </div>	<p>Ref. FF78</p> <div style="display: flex; justify-content: space-around; align-items: center;"> <div style="border: 1px solid black; padding: 2px;">HSSCo</div> <div style="border: 1px solid black; padding: 2px;">DIN 847</div> <div style="border: 1px solid black; padding: 2px; text-align: center;">60° </div> </div>	<p>Ref. FF79</p> <div style="display: flex; justify-content: space-around; align-items: center;"> <div style="border: 1px solid black; padding: 2px;">HSSCo</div> <div style="border: 1px solid black; padding: 2px;">DIN 847</div> <div style="border: 1px solid black; padding: 2px; text-align: center;">90° </div> </div>
---	---	---

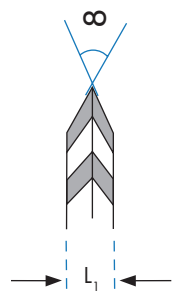
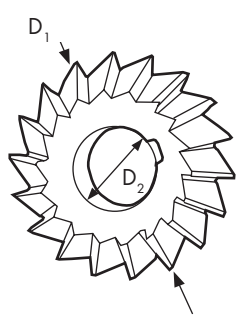

FF77						FF78						FF79					
D1 mm	D2 mm	L1 mm	∞	Z	€	D1 mm	D2 mm	L1 mm	∞	Z	€	D1 mm	D2 mm	L1 mm	∞	Z	€
50	16	8	45°	20	185,21	50	16	10	60°	18	188,85	50	16	14	90°	16	188,85
63	22	10	45°	22	220,30	63	22	14	60°	20	224,63	63	22	20	90°	18	224,63
80	27	12	45°	24	307,59	80	27	18	60°	22	313,61	80	27	22	90°	20	313,61
100	32	18	45°	26	384,54	100	32	25	60°	24	392,08	100	32	32	90°	22	392,08

HSSCo SINGLE ANGLE MILLING CUTTERS

<p>Ref. FF91</p> <div style="display: flex; justify-content: space-around; align-items: center;"> <div style="border: 1px solid black; padding: 2px;">HSSCo</div> <div style="border: 1px solid black; padding: 2px;">DIN 842</div> <div style="border: 1px solid black; padding: 2px; text-align: center;">50° </div> </div>	<p>Ref. FF90</p> <div style="display: flex; justify-content: space-around; align-items: center;"> <div style="border: 1px solid black; padding: 2px;">HSSCo</div> <div style="border: 1px solid black; padding: 2px;">DIN 842</div> <div style="border: 1px solid black; padding: 2px; text-align: center;">60° </div> </div>
---	---

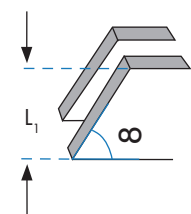
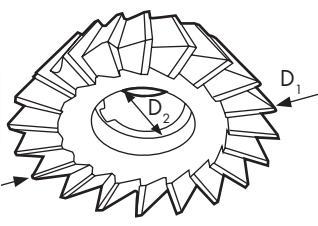

FF91						FF90					
D1 mm	D2 mm	L1 mm	∞	Z	€	D1 mm	D2 mm	L1 mm	∞	Z	€
40	10	13	50°	14	146,45	40	10	13	60°	14	143,60
50	13	16	50°	16	180,60	50	13	16	60°	16	177,09
63	16	20	50°	18	228,29	63	16	20	60°	18	223,86
80	22	25	50°	20	328,91	80	22	25	60°	20	322,54
100	27	32	50°	22	477,05	100	27	32	60°	22	467,77
125	32	40	50°	24	787,77	125	32	40	60°	24	772,50
160	40	50	50°	30	1.378,02	160	40	50	60°	30	1.351,27

2026 PRICE LIST
GROSS PRICE 2025 **+7%**
Effective from 4 May 2026

BLUE-MASTER[®]
by *celesa*



KEY CUTTERS

LOCKSMITHING TOOLS

THE WIDEST RANGE OF TOOLS FOR LOCKSMITHS

DIN
338CARBIDE
TIPPED

BRIGHT

CAST
IRON

BC7

BC7B

Ø mm	L1 x L2 mm		€/U.		€/U.
6,00	93 x 57	BC70600	22,79	BC70600B	26,91

Carbide Tipped twist drill (DIN 338) for hard metals. High hardness twist drill for hard metals use in locksmithing. Go to page 51 for full information.

DIN
338HSSCo
5%

GOLD

120
Kg/mm²

BC5

BCSF

BC5B

Ø mm	L1 x L2 mm		€/U.		€		€
6,00	93 x 57	BC50600	4,97	BC50600F	5,55	BC50600B	6,44

HSSCo twist drill (DIN 338) for metals of 120 Kg/mm². High hardness twist drill for general use in locksmithing. Go to page 50 for full information.

DIN
338CARBIDE
TIPPED

BRIGHT

70 HR_c

BC98

BC98B

Ø mm	L1 x L2 mm		€/U.		€/U.
6,00	93 x 57	BC980600	16,84	BC980600B	20,96

Carbide Tipped twist drill (DIN 338) for very hard metals. High hardness twist drill for very hard metals use in locksmithing. Go to page 51 for full information.

SOLID
CARBIDETOL D₁
h7TOL D₂
h6

TiAIN

HARDOX
600HIGH
PERFORMANCE70
HR_c

BC85

BC85B

Ø mm	L1 x L2 mm		€/U.		€/U.
6,00	75 x 35	BC850600	82,78	BC850600B	87,93

Solid Carbide Drill for hardened steel (up to 70 HR_c). Maximum hardness drill for hardened metals use in locksmithing. Go to page 70 for full information.

Upon demand we can provide our package of an electromagnetic anti-theft device with an additional charge of 0,07 € per unit. They can be placed in all the products or randomly.

CARBIDE DRILLS FOR CYLINDER

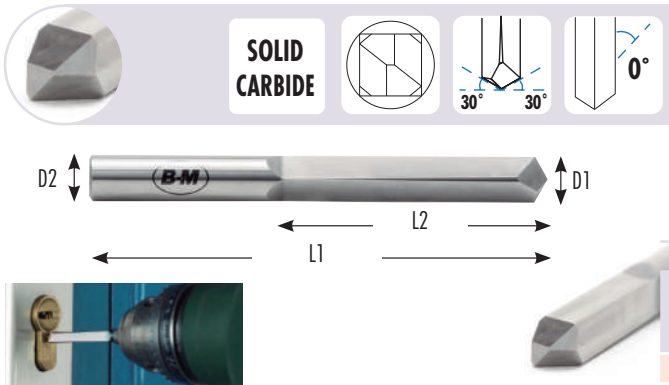

**SOLID
CARBIDE**



Solid Carbide square section drill for cylinders and anti-drilling pins.
The drill N°1 to drill high hardness cylinders.

* for antidrilling pins cylinder we recommend to drill at 300 RPM.

D1 mm	D2 mm	L2 mm	L1 mm	1U.	€	1U.	€
6	6	33	60	BCC06X60MD	61,93	BCC06X60MDB	67,08

End mills

Pink

SPECIAL ROTARY BURRS FOR CYLINDERS

**TYPE
C**

**CARBIDE
/ HSS**



Solid Carbide Rotary Burr for locksmith use, also known as Vampire. Semi-spherical geometry and total lengths from 60 to 150mm. The most appropriate burr for cylinders. Select the adequate option for your application among our wide range.

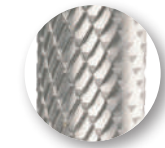
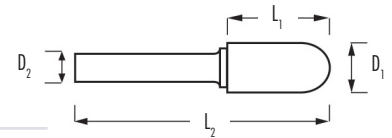

	D1 mm	D2 mm	L1 mm	L2 mm			1U.		1U.
3 mm. SHANK	3.0	3	25.0	60	HSS	Y548TG2	21,84	Y548TG2B	26,04
	3.0	3	25.0	60	Monobloc	C30325-6	37,80	C30325-6B	41,96
6 mm. SHANK	6.0	6	25.0	50	Monobloc	C60625-6	41,07	C60625-6B	45,23
	6.0	6	25.0	60	Monobloc	C60625-60-6	46,26	C60625-60-6B	50,42
	6.0	6	25.0	80	Monobloc	C60625-80-6	55,27	C60625-80-6B	59,43
	6.0	6	25.0	100	Monobloc	C60625-100-6	61,66	C60625-100-6B	65,82
	6.0	6	25.0	120	Monobloc	C60625-120-6	92,50	C60625-120-6B	96,66
	6.0	6	25.0	150	Monobloc	C60625-150-6	123,33	C60625-150-6B	127,49



REFERENCE	SETC60625
QUANTITY	4
CONTENT	C60625-100-6 / C60625-80-6 C60625-60-6 / C60625-6
P.V.P. €	198,81



CYLINDRICAL SOLID CARBIDE ROTARY BURR WITH DRILL TIP AND SERRATED FLUTES

NEW

Ref. RCC

CARBIDE



INOX



Cu-Ni-La



PHENOLIC



Specially suited for drilling high-security armoured cylinders.

High-precision drilling thanks to its centring drill tip.

The 2 serrated flutes grind the material during milling, allowing an optimal tool sliding.

Its flutes relieve operating stress, providing excellent chip evacuation.

Use it with a powerful straight grinder. If possible, with speed regulation. 14,000–28,000 rpm for optimal performance.

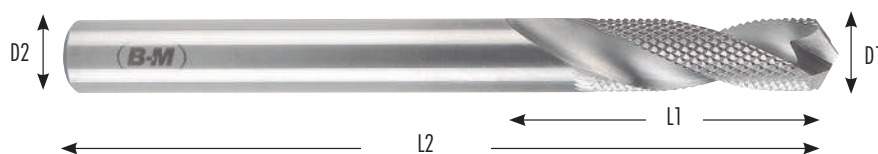

D1 mm	D2 mm	L1 mm	L2 mm		€
5.0	5	20.0	50	RCC0500	38,46
6.0	6	25.0	63	RCC0600	45,74
8.0	8	25.0	63	RCC0800	76,15
10.0	10	25.0	63	RCC1000	96,74

CYLINDER WITH END CUT

TYPE
A/E

CARBIDE



Solid Carbide Rotary Burr A/F form (cylinder with end cut) and C form (semi-spherical). The most appropriate burr for cylinders. Select the adequate option for your application among our wide range.

Go to pages 335 for full information.



6 mm. SHANK



D1 mm	L2 mm	D2 mm	L1 mm			1U.		1U.
6.0	25.0	6	50	Monobloc	A60625-6E	36,62	A60625-6EB	40,78



On request, we can equip our package with an anti-theft system using electromagnetism with an additional charge of 0,07 € per unit, which can be placed on all pieces or randomly.

CUTTERS FOR JMA KEY DUPLICATING MACHINES

DOUBLE ANGLE CUTTERS



Ref.FLL99: Double angle cutter without lateral chamfer 80x5x16 Z110.



Ref. FLLFP4

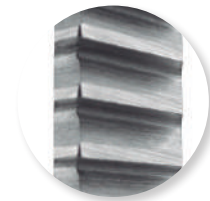

End mills

Pink

Ref. BM	Ref. JMA	MACHINE TYPES	MATERIAL	mm		mm	β°	Z	mm	FLL	€
				mm	mm						
FLLFP1 (FLL02)	FP1	OREGON	HSSV	25	10	10	100°	60	0,1		102,56
FLLFP2W	FP2W	VIRGINIA	CARBIDE	40	10	6	70°	70	0,1		403,37
FLLFP3 (FLL04)	FP3	KIS, SPRINT	HSSV	50	12	6	90°	80	0,15		124,82
FLLFP4 (FLL06)	FP4	KIS	HSSV	53	12,7	6,35	45/15°	72	0,6		128,73
FLLFP5	FP5	JMA	HSSV	57	12,7	5	90°	80	0,15		160,44
FLLFP6 (FLL09)	FP6	KIS, SPRINT	HSSV	60	12,7	5	84°	140	0,1		124,82
FLLFP11ECCO (FLL11)	FP11/ECCO-009	ECCO, ECCO-PLUS	HSSV	63	16	5	84°	80	1		119,41
FLLFP11W	FP11W	ECCO, ECCO-PLUS	CARBIDE	63	16	5	84°	80	1		365,18
FLLFP12	FP12	TUCSON	HSSV	63	16	5	80°	80	1,25		128,73
FLLFP12W	FP12W	TUCSON	CARBIDE	63	16	5	80°	80	1,25		394,30
FLLFP13	FP13	DALLAS	HSSV	63	16	5	84°	100	1		160,31
FLLCU14	CU14	ECCO, ECCO-PLUS	HSSV	63	16	5	80°	80	1,25		157,09
FLLFP16 (FLL13)	FP16	PROCEDURE	HSSV	70	16	5,25	76°	100	1		160,31
FLLFP16W	FP16W	PROCEDURE	CARBIDE	70	16	5,25	76°	100	1		394,30
SLLP01	FP24 DAKOTA = P01	DAKOTA, ERREBI SARATOGA, NEVADA, DENVER, TITAN, VIENNA	HSSV	80	16	5	84°	110	1		103,50
SLLP01/120	FP24 DAKOTA=P01/120		HSSV	80	16	5	84°	120	1		105,47
FLLFP24 (FLL16)	FP24 ERREBI		HSSV	80	16	5	84°	110	1,25		98,46
FLLFP24W	FP24W ERREBI		CARBIDE	80	16	5	84°	110	1,25		365,18
FLL99	FP24		HSSV	80	16	5	84°	110	0		113,76

FURTHER GENERAL PURPOSE KEY CUTTERS

Ref. BM	MACHINE TYPES	MATERIAL	mm		mm	Z	FLL	€
			mm	mm				
FLL01	FLORA	HSSV	23	10	5	36		118,08
FLL03	YALE	HSSV	40	8	5	80		128,11
FLL05	NOVACLAU	HSSV	52	16	5	110		151,27
FLL07	KIS	HSSV	53	12,7	6	80		168,31
FLL08	KIS	HSSV	55	12	6	80		168,31
FLL10	NOVACLAU	HSSV	61	12,7	6,5	140		171,37
FLL11	NOVACLAU	HSSV	62	16	5	80		168,04
FLL12	NOVACLAU	HSSV	63	16	5	140		168,04
FLL14	WALKIN	HSSV	70	15	6,5	150		155,67
FLL15	LINCE	HSSV	70	13	7	88		173,09

DOUBLE ANGLE CUTTERS

CUTTERS FOR JMA KEY DUPLICATING MACHINES

SIDE MILLING CUTTER



Ref. FLLFP19



Ref. BM	Ref. JMA	MACHINE TYPES	MATERIAL	mm		mm	Z	FLL
								€
FLL17		JMA-NOVACLAU-WALKIN	HSSV	35	12	3,15	50	116,98
FLL18		JMA-NOVACLAU-WALKIN	HSSV	63	15	1,40	80	143,05
FLLFP7	FP7	ECCO BIT, DETROIT	HSSV	63	16	1,25	80	128,17
FLLFP7W	FP7W	ECCO BIT, DETROIT	CARBIDE	63	16	1,25	80	318,51
FLLFP8 (FLL19)	FP8	ECCO BIT, DETROIT	HSSV	63	16	1,4	80	129,59
FLL20		JMA-NOVACLAU-WALKIN	HSSV	70	16	1,40	100	150,07
FLLFP17	FP17	TITAN BIT, SARATOGA, YAKARTA	HSSV	80	16	1,25	100	131,12
FLLFP17W	FP17W	TITAN BIT, SARATOGA, YAKARTA	CARBIDE	80	16	1,25	100	334,63
FLLFP18	FP18	ATLANTA, TOPEKA	HSSV	80	22	1,25	100	133,74
FLLFP18W	FP18W	ATLANTA, TOPEKA	CARBIDE	80	22	1,25	100	334,63
FLLFP19 (FLL21)	FP19	SARATOGA, YAKARTA, TITAN BIT, DAKOTA	HSSV	80	16	1,4	100	134,24
FLLFP19W	FP19W	SARATOGA, YAKARTA, TITAN BIT, DAKOTA	CARBIDE	80	16	1,4	100	313,42
FLLFP20 (FLL22)	FP20	ATLANTA, TOPEKA	HSSV	80	22	1,4	100	134,24
FLLFP21 (FLL24)	FP21/SLLSG2	ATLANTA, TOPEKA, DUPLEX, KANSAS	HSSV	80	22	1,5	100	137,96
FLLFP21W	FP21W	ATLANTA, TOPEKA, DUPLEX, KANSAS	CARBIDE	80	22	1,5	100	341,17

MILLING SLOT CUTTERS



Ref. FLLFP22W

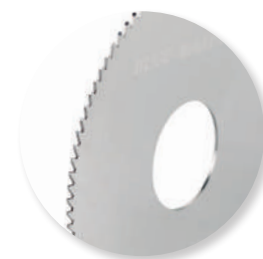

Ref. BM	Ref. JMA	MACHINE TYPES	MATERIAL	mm		mm	Z	FLL
								€
FLLFP9	FP9	ECCO BIT	HSSV	63	16	1	80	84,50
FLLFP10	FP10	ECCO FORD, ECCO ABBLOY, PASADENA, NEBRASCA	HSSV	63	16	2,4	80	84,50
FLLFP22	FP22	TITAN BIT, DAKOTA, SARATOGA	HSSV	80	16	1	100	90,14
FLLFP22W	FP22W	TITAN BIT, DAKOTA, SARATOGA	CARBIDE	80	16	1	100	308,47
FLLFP23	FP23	DUPLEX, ATLANTA, TOPEKA	HSSV	80	22	1	100	93,39
FLLFP23W	FP23W	DUPLEX, ATLANTA, TOPEKA	CARBIDE	80	22	1	100	308,47
FF68801416100CO	-	TITAN, DAKOTA, SARATOGA, YAKARTA	HSSCo	80	16	1,4	100	90,79
FLLFP26 (FLL23)	FP26	G, SENNA, DAKOTA, SARATOGA, YAKARTA	HSSV	80	16	1,5	100	94,68
FLLFP26W	FP26W	G, SENNA, DAKOTA, SARATOGA,	CARBIDE	80	16	1,5	100	312,79

CUTTERS FOR JMA KEY DUPLICATING MACHINES

LASER CUTTERS

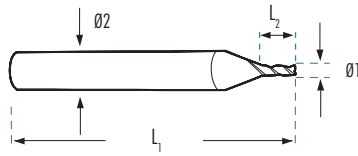

Ref. FLLF3



End mills

Pink

Ref. BM	Ref. JMA	MACHINE TYPES	MATERIAL	Ø1 mm	L1 mm	Ø2 mm	L2 mm	Z	FLL
									€
FLLF3Z3	(FLL32)	≈ F3	HSSCo	1,5	45	6	3	3	44,50
FLLF3	(FLL44)	F3	HSSCo	1,5	45	6	3	2	41,65
FLLF3W	(FLL45)	F3W	CARBIDE	1,5	45	6	3	2	135,41
FLLF33	(FLL53)	F33	HSSCo	2	45	6	4	3	40,21
FLL11Z3	(FLL33)	≈ F11	HSSCo	2,5	45	6	5	3	40,21
FLLF11	(FLL48)	F11	HSSCo	2,5	45	6	5	2	35,99
FLLF11W	(FLL49)	F11W	CARBIDE	2,5	45	6	5	2	102,50
FLLF17	(FLL34)	F17	HSSCo	3	45	6	6	3	40,21
FLLF8Z3	(FLL35)	≈ F8	HSSCo	4	45	6	6	3	46,80
FLLF8	(FLL46)	F8	HSSCo	4	45	6	7	2	41,65
FLLF8W	(FLL47)	F8W	CARBIDE	4	45	6	6	2	127,08
FLLF77	(FLL36)	-	HSSCo	5	45	6	7	3	46,80
FLLF78	(FLL37)	-	HSSCo	6	45	6	8	3	46,80
FLLF78W	(FLL54)	-	CARBIDE	6	45	6	8	3	102,50
FLLF78WZ4	(FLL55)	-	CARBIDE	6	45	6	8	4	102,50

UNIVERSAL DIMPLE CUTTERS FOR JMA AND SILCA DUPLICATING MACHINES

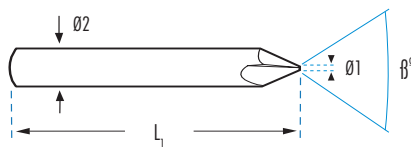

Ref. FLLF1



Ref. BM	Ref. JMA	MACHINE TYPES	MATERIAL	β°	Ø1 mm	L1 mm	Ø2 mm	Z	FLL
									€
FLLF82	-	ALBANY	HSSCo	82°	0,9	45	6	2	27,42
FLLF1	(FLL43)	ARIZONA	HSSCo	90°	0,8	45	6	2	27,42
FLLF1W	(FLL42)	COLUMBIA	CARBIDE	90°	0,8	45	6	2	84,92
FLLF5	(FLL52)	DAKAR	HSSCo	90°	0,9	45	6	2	27,42
FLLF5W	(FLL42)	DAKAR EXPRESS	CARBIDE	90°	0,9	45	6	2	84,92
FLLF95	-	DAY T-COL	HSSCo	95°	0,9	45	6	2	27,42
FLLF13	(FLL50)	DAYTONA	HSSCo	100°	0,8	45	6	2	27,42
FLLF13W	(FLL51)	DAYTONA	CARBIDE	100°	0,8	45	6	2	79,45
FLLF105	-	X CODE	HSSCo	105°	0,9	45	6	2	27,42

CUTTERS FOR JMA KEY DUPLICATING MACHINES

TRACER POINTS

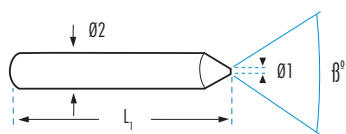

Ref. FLLP1

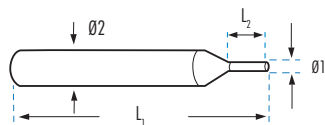

Ref. FLLP3



FLL

Ref. BM	Ref. JMA	MACHINE TYPES	MATERIAL	β°	\varnothing_1 mm	L_1 mm	\varnothing_2 mm	L_2 mm	€
FLLP1	(PLL38)	P1	HSSV	90°	0,8	45	6	-	22,32
FLLP3	(PLL32)	P3	HSSV	-	1,5	45	6	4	39,48
FLLP5		P5	HSSV	90°	0,9	45	6	-	22,32
FLLP8	(PLL35)	P8	HSSV	-	4	45	6	7	39,48
FLLP11	(PLL33)	P11	HSSV	-	2,5	45	6	4	39,48
FLLP13	(PLL50)	P13	HSSV	100°	0,8	45	6	-	22,32
FLLP17	(PLL34)	P17	HSSV	-	3	45	6	6	39,48
FLLP52	(PLL52)	-	HSSV	90°	0,9	45	6	-	22,32
FLLP77	(PLL36)	-	HSSV	-	5	45	6	7	39,48
FLLP78	(PLL37)	-	HSSV	-	6	45	6	8	39,48

KEY LINE CUTTERS

Ref. BM	Ref. JMA	MACHINE TYPES	MATERIAL	β°	\varnothing_1 mm	L_1 mm	\varnothing_2 mm	L_2 mm	€
V001	-	KEY LINE	CARBIDE	90°	0,4	32	4	-	144,98
V003	-		CARBIDE	-	2,5	32	4	5	144,98
V004	-		CARBIDE	82°	0,5	32	4	-	144,98
V007	-		CARBIDE	100°	0,4	32	4	-	144,98
V012	-		CARBIDE	-	1,5	32	4	4	178,26

CUTTERS FOR SILCA KEY DUPLICATING MACHINES

DOUBLE ANGLE CUTTERS



Ref. SLLP01

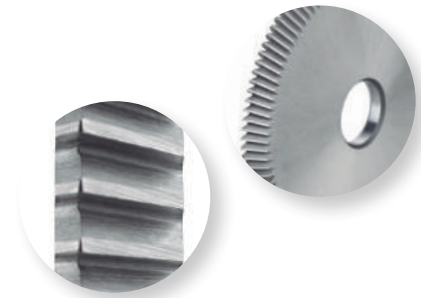

End mills

Pink

Ref. BM	Ref. SILCA	MACHINE TYPES	MATERIAL	mm		mm	β°	Z	mm	SLL
				mm	mm					€
SLL01F	O1F	FUTURA PRO	CARBIDE	60,4	9,52	3,05	40	110	0	160,12
SLLU01	U01	UNOCODE/ULTRACODE	HSSV	60,4	9,52	5,25	80	72	0,5	128,62
SLLU01W	U01W	UNOCODE/ULTRACODE	CARBIDE	60,4	9,52	5,25	80	72	0,5	410,92
SLLP21	P21	SILCA DELTA	HSSV	60,4	9,52	5,25	84	72	0,5	116,01
SLLP01	P01	BRAVO/POKER/REKORD BRAVO SUPER/SUPER MASTER	HSSV	80	16	5	84	110	1	103,50
SLLP01/120	P01/120		HSSV	80	16	5	84	120	1	105,47
SLLP01W	P01W		CARBIDE	80	16	5	84	110	1	339,09

SIDE MILLING CUTTER



Ref. SLLSG2



Ref. BM	Ref. SILCA	MACHINE TYPES	MATERIAL	mm		mm	Z	SLL
				mm	mm			€
SLLY2KW	Y2KW	DELTA	CARBIDE	63	16	1,35	80	310,73
SLLSG19	SG19	DELTA	HSSV	64,6	9,52	1,5	40	87,81
SLLSG19W	SG19W	DELTA	CARBIDE	64,6	9,52	1,5	40	295,76
SLLSG18	SG18	DELTA	HSSV	64,6	9,52	2,4	40	87,81
SLLSG18W	SG18W	DELTA	CARBIDE	64,6	9,52	2,4	40	295,76
SLLSG6	SG6	LANCER	HSSV	80	22	1,3	100	90,24
SLLSG6W	SG6W	LANCER	CARBIDE	80	22	1,3	100	310,73
SLLSG2	SG2	TARGA/TECH3/TECNICA	HSSV	80	22	1,5	100	90,24
SLLSG2W	SG2W	TARGA/TECH3/TECNICA	CARBIDE	80	22	1,5	100	310,73
SLLFSC4-CAW	FSC4-CAW	DELTA	CARBIDE	80	22	1,8	100	323,01

CUTTERS FOR SILCA KEY DUPLICATING MACHINES

MILLING SLOT CUTTERS



Ref. SLLSG7W



Ref. BM	Ref. SILCA	MACHINE TYPES	MATERIAL	mm			Z	SLL	€
SLLSG14W	SG14W	DELTA	CARBIDE	60,4	9,52	1,14	80	248,49	
SLLGB1	GB1	ULTRACODE / UNOCODE	HSSV	60,4	9,52	1,7	66	91,16	
SLL05	05	UNOCODE/ULTRACODE	HSSV	60,4	9,52	1,8	68	91,16	
SLL05W	05W	UNOCODE/ULTRACODE	CARBIDE	60,4	9,52	1,8	68	260,78	
SLLCU-15C	CU-15C	OPERA /TARGA	CARBIDE	63	16	1,5	80	339,67	
SLLSG17	SG17	DELTA	HSSV	64,6	9,52	1,8	70	91,16	
SLLSG17W	SG17W	DELTA	CARBIDE	64,6	9,52	1,8	70	286,44	
SLLSG13	SG13	UNOCODE / DELTA	HSSV	64,6	9,52	2	70	91,16	
SLLSG13W	SG13W	UNOCODE / DELTA	CARBIDE	64,6	9,52	2	70	339,67	
SLL06	06	UNOCODE/ULTRACODE	HSSV	64,6	9,52	2,4	70	91,16	
SLL06W	06W	UNOCODE/ULTRACODE	CARBIDE	64,6	9,52	2,4	70	276,96	
SLLSG3	SG3	OPERA /TARGA/TECH3	HSSV	80	22	1	100	86,72	
SLLSG3W	SG3W	OPERA /TARGA/TECH3	CARBIDE	80	22	1	100	286,44	
SLLSG4	SG4	OPERA /TARGA/TECH3	HSSV	80	22	1,25	100	86,72	
SLLSG4W	SG4W	OPERA /TARGA/TECH3	CARBIDE	80	22	1,25	100	286,44	
SLLSG5	SG5	LANCER	HSSV	80	22	1,3	100	86,72	
SLLSG5W	SG5W	LANCER	CARBIDE	80	22	1,3	100	286,44	
SLLSG7	SG7	OPERA / TARGA	HSSV	80	22	1,4	100	86,72	
SLLSG7M35	SG7M35	OPERA / TARGA	HSSCo	80	22	1,4	100	111,02	
SLLSG7W	SG7W	LANCER	CARBIDE	80	22	1,4	100	286,44	
SLLSG1	SG1	OPERA /TARGA/TECH3	HSSV	80	22	1,5	100	86,72	
SLLSG1W	SG1W	OPERA /TARGA/TECH3	CARBIDE	80	22	1,5	100	286,44	
SLLSG8	SG8	TECH3 / TECHNICA	HSSV	80	22	1,75	100	86,72	
SLLSG10	SG10	LANCER	HSSV	80	22	2	100	86,72	
SLLSG10W	SG10W	LANCER/ OPERA /TARGA	CARBIDE	80	22	2	100	298,58	
SLLSG11	SG11	SILCA GT40	HSSV	80	22	2,3	100	86,72	
SLLSG12	SG12	TARGA/TECH3/TECNICA/OPERA	HSSV	80	22	2,5	100	86,72	
SLLSG58400	SG58400	DELTA	CARBIDE	80	22	4	100	274,28	
SLLPL1	PL1	PRIMA LASER	HSSV	100	22	1	100	149,62	
SLLPL1W	PL1W	PRIMA LASER	CARBIDE	100	22	1	100	383,91	
SLLPL1,25	PL1,25	PRIMA LASER	HSSV	100	22	1,25	100	149,62	
SLLPL1,25W	PL1,25W	PRIMA LASER	CARBIDE	100	22	1,25	100	366,10	
SLLPL1,5	PL1,5	PRIMA LASER	HSSV	100	22	1,5	100	149,62	
SLLPL1,5W	PL1,5W	PRIMA LASER	CARBIDE	100	22	1,5	100	366,10	
SLLPL1,7W	PL1,7W	PRIMA LASER	CARBIDE	100	22	1,7	100	377,32	
SLLPL2	PL2.0	PRIMA LASER	HSSV	100	22	2	100	149,62	
SLLPL2W	PL2.0W	PRIMA LASER	CARBIDE	100	22	2	100	377,32	

CUTTERS FOR SILCA KEY DUPLICATING MACHINES

DIMPLE CUTTERS

MATRIX



Ref. SLLF1W

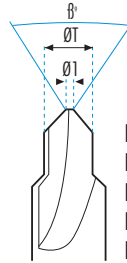
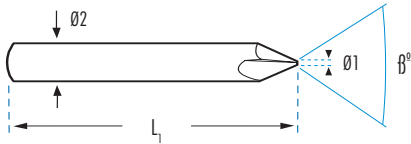

Ref. SLLF19-CAZ1
Ref. SLLF19
Ref. SLLF43
Ref. SLLF21
Ref. SLLF25

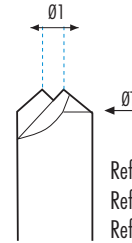

Ref. SLLF12B
Ref. SLLF15
Ref. SLLF37



End mills

Pink

Ref. BM	Ref. SILCA	UNIV.	MACHINE TYPES	MATERIAL	β°	Ø1 mm	L1 mm	Ø2 mm	Z	SLL
										€
SLLF1Z1	F1	FLLF1	MATRIX	HSSV	90°	0,7	48	6	1	58,00
SLLF1	F1	FLLF1	MATRIX	HSSV	90°	0,7	48	6	2	58,00
SLLF1W	F1W	FLLF1W	MATRIX	CARBIDE	90°	0,7	48	6	1	103,69
SLLF4	F4	FLLF1	MATRIX	HSSV	90°	0,4	48	6	1	58,00
SLLF5	F5	FLLF5	MATRIX	HSSV	90°	0,9	48	6	1	58,00
SLLF6	F6	FLLF105	MATRIX	HSSV	106°	1	48	6	1	58,00
SLLF7	F7	FLLF82	MATRIX	HSSV	72°	0,8	48	6	2	58,02
SLLF12A	F12A	FLLF13	MATRIX	HSSV	100°	0,4	48	6	1	58,00
SLLF12B	F12B	FLLF1	MATRIX	HSSV	90°	8 x 1,8*	48	6	2	58,00
SLLF13	F13	FLLF1	MATRIX	HSSV	90°	0,77	48	6	1	58,00
SLLF14	F14	FLLF5	MATRIX	HSSV	90°	0,9	48	6	1	58,00
SLLF15	F15	FLLF1	MATRIX	HSSV	90°	8 x 0,8*	48	6	1	66,47
SLLF19	F19	FLLF1	MATRIX	HSSCo	90°	2,2 x 0,6*	48	6	1	58,02
SLLF19-CAZ1	F19-CA	FLLF1W	MATRIX	CARBIDE	90°	2,2 x 0,6*	48	6	1	103,69
SLLF20	F20	FLLF1	MATRIX	HSSV	90°	0,45	48	6	2	58,00
SLLF21	F21	FLLF82	MATRIX	HSSCo	85°	3,2 x 0,8*	48	6	1	66,47
SLLF23	F23	FLLF1	MATRIX	HSSV	90°	1,5	48	6	2	66,47
SLLF24	F24	FLLF13	MATRIX	HSSV	100°	1,3	48	6	1	58,00
SLLF25	F25	FLLF1	MATRIX	HSSV	90°	3,5 x 0,65*	48	6	1	58,00
SLLF26	F26	FLLF82	MATRIX	HSSV	82°	0,8	48	6	1	58,00
SLLF27-CA	F27-CA	-	MATRIX	CARBIDE	60°	2,4 x 1,9*	48	6	1	138,52
SLLF28	F28	-	MATRIX	HSSV	76°	0,76	48	6	1	58,00
SLLF29	F29	-	MATRIX	HSSV	76°	1,9 x 0,76*	48	6	1	58,00
SLLF34	F34	-	MATRIX	HSSV	50°	1,5	48	6	1	58,00
SLLF34-CAZ1	F34-CA	-	MATRIX	CARBIDE	50°	1,5	48	6	1	103,69
SLLF37	F37	FLLF1	MATRIX	HSSV	90°	6 x 2,1*	48	6	2	66,47
SLLF39	F39	FLLF1	MATRIX	HSSV	90°	0,6	48	6	2	70,45
SLLF42	F42	FLLF13	MATRIX	HSSV	100°	0,7	48	6	1	58,00
SLLF43	F43	FLLF1	MATRIX	HSSCo	90°	1	48	6	1	58,00
SLLF45	F45	-	MATRIX	HSSV	130°	0,56	48	6	1	58,02
SLLF46	F46	FLLF13	MATRIX	HSSV	100°	0,65	48	6	1	58,02
SLLF49	F49	FLLF95	MATRIX	HSSV	95°	0,8	48	6	1	66,47
SLLF50	F50	FLLF13	MATRIX	HSSV	100°	0,5	48	6	1	66,47
SLLF52-CA	F52-CA	-	MATRIX	CARBIDE	54°	0,86	48	6	2	58,00
SLLF59	F59	FLLF1	MATRIX	HSSV	90°	0,8	48	6	2	58,00
SLL01D	01D	-	FUTURA PRO	CARBIDE	90°	0,4	30	6	2	65,12
SLL02D	02D	-	FUTURA PRO	CARBIDE	100°	0,4	30	6	2	65,12

* Ø1 x Ø1

CUTTERS FOR SILCA KEY DUPLICATING MACHINES

LASER CUTTERS

MATRIX

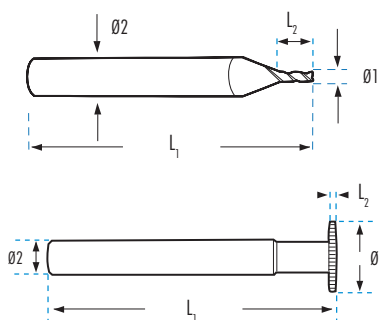

Ref. SLLF3



Ref. BM	Ref. SILCA	MACHINE TYPES	MATERIAL	Ø ₁ mm	L ₁ mm	Ø ₂ mm	L ₂ mm	Z	SLL
									€
SLLF3	F3	MATRIX	HSSV	1,5	48	6	2	3	58,00
SLLF8	F8	MATRIX	HSSV	4	48	6	13	3	58,00
SLLF11	F11	MATRIX	HSSV	2,5	48	6	7	3	58,00
SLLF22	F22	MATRIX	HSSV	2,5	42	6	6	3	58,00
SLLF30	F30	MATRIX	HSSV	3	48	6	6	3	58,00
SLLF30Z2	F30	MATRIX	HSSV	3	48	6	6	2	68,17
SLLF44	F44	MATRIX	HSSV	2	40	6	6	3	58,00
SLL01L	O1L	FUTURA PRO	CARBIDE	2,5	30	6	3	3	65,12
SLL02L	O2L	FUTURA PRO	CARBIDE	2	30	6	3	3	65,12

LASER CUTTERS

QUATTROCODE /TRIAX-E

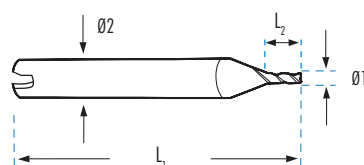

Ref. SLLW133



Ref. BM	Ref. SILCA	MACHINE TYPES	MATERIAL	Ø ₁ mm	L ₁ mm	Ø ₂ mm	L ₂ mm	Z	SLL
									€
SLLW101	W101	QUATTROCODE /TRIAX-E	CARBIDE	2,5	40	6	6	3	132,31
SLLW114	W114	QUATTROCODE /TRIAX-E	CARBIDE	2	40	6	6	3	132,33
SLLW117	W117	QUATTROCODE /TRIAX-E	CARBIDE	5	48	6	R1	4	107,39
SLLW129	W129	QUATTROCODE /TRIAX-E	CARBIDE	3	40	6	6	3	132,31
SLLW131	W131	QUATTROCODE /TRIAX-E	CARBIDE	6	40	6	5	3	97,67
SLLW133	W133	QUATTROCODE /TRIAX-E	CARBIDE	1,5	40	6	3	3	144,50
SLLW134	W134	QUATTROCODE /TRIAX-E	CARBIDE	4	40	6	7	3	132,33
SLLW219	W219	QUATTROCODE /TRIAX-E	CARBIDE	1,2	40	6	2	3	132,31
SLLW235	W235	QUATTROCODE /TRIAX-E	CARBIDE	1,1	40	6	2	3	132,28
SLLW268	W268	QUATTROCODE /TRIAX-E	CARBIDE	1,5	40	6	6	2	132,40

CUTTERS FOR SILCA KEY DUPLICATING MACHINES

DIMPLE CUTTERS

QUATTROCODE /TRIAX-E



Ref. SLLW103

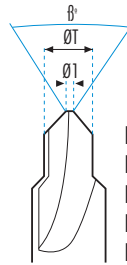
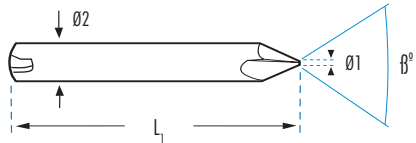

Ref. SLLW115
Ref. SLLW128
Ref. SLLW135
Ref. SLLW145
Ref. SLLW210

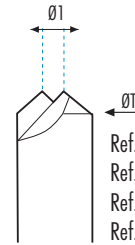

Ref. SLLW111
Ref. SLLW126
Ref. SLLW127
Ref. SLLW139



End mills

Pink

Ref. BM	Ref. SILCA	MACHINE TYPES	MATERIAL	β°	\varnothing_1 mm	L ₁ mm	\varnothing_2 mm	Z	€
SLLW102	W102	QUATTROCODE /TRIAX-E	CARBIDE	106°	1	40	6	2	92,86
SLLW103	W103/W299	QUATTROCODE /TRIAX-E	CARBIDE	90°	0,8	40	6	2	92,86
SLLW104	W104	QUATTROCODE /TRIAX-E	CARBIDE	90°	1,2	40	6	2	92,86
SLLW105	W105	QUATTROCODE /TRIAX-E	CARBIDE	90°	0,7	40	6	2	92,86
SLLW106	W106	QUATTROCODE /TRIAX-E	CARBIDE	90°	0,6	40	6	2	92,86
SLLW107	W107	QUATTROCODE /TRIAX-E	CARBIDE	90°	0,9	40	6	2	92,86
SLLW108	W108	QUATTROCODE /TRIAX-E	CARBIDE	82°	0,9	40	6	2	92,86
SLLW109	W109	QUATTROCODE /TRIAX-E	CARBIDE	110°	0,4	40	6	2	92,86
SLLW110	W110	QUATTROCODE /TRIAX-E	CARBIDE	100°	0,6	40	6	2	92,86
SLLW111	W111	QUATTROCODE /TRIAX-E	CARBIDE	96°	8x2,75*	40	6	2	104,32
SLLW112	W112	QUATTROCODE /TRIAX-E	CARBIDE	60°/0°	1,5	40	6	2	93,46
SLLW113	W113	QUATTROCODE /TRIAX-E	CARBIDE	100°	0,76	40	6	2	92,86
SLLW115	W115	QUATTROCODE /TRIAX-E	CARBIDE	54°	4x0,86*	40	6	1	124,49
SLLW116	W116	QUATTROCODE /TRIAX-E	CARBIDE	90°	1	40	6	2	92,86
SLLW118	W118	QUATTROCODE /TRIAX-E	CARBIDE	120°	0,6	40	6	2	92,86
SLLW119	W119	QUATTROCODE /TRIAX-E	CARBIDE	85°	0,3	40	6	2	92,86
SLLW121	W121	QUATTROCODE /TRIAX-E	CARBIDE	86°	0,05	48	6	3	129,21
SLLW122	W122	QUATTROCODE /TRIAX-E	CARBIDE	90°	0,55	40	6	2	111,44
SLLW123	W123	QUATTROCODE /TRIAX-E	CARBIDE	76°	0,9	40	6	2	92,86
SLLW124	W124	QUATTROCODE /TRIAX-E	CARBIDE	90°	8x0,8*	48	6	3	178,01
SLLW126	W126	QUATTROCODE /TRIAX-E	CARBIDE	80°	3,3	48	6	2	111,44
SLLW127	W127	QUATTROCODE /TRIAX-E	CARBIDE	80°	2,1	48	6	2	111,44
SLLW128	W128	QUATTROCODE /TRIAX-E	CARBIDE	90°	4x0,55*	48	6	1	124,49
SLLW130	W130	QUATTROCODE /TRIAX-E	CARBIDE	90°	1,4	40	6	2	125,01
SLLW132	W132	QUATTROCODE /TRIAX-E	CARBIDE	60°	2	40	6	1	124,49
SLLW135	W135	QUATTROCODE /TRIAX-E	CARBIDE	90°	4x0,55*	40	6	2	124,42
SLLW136	W136	QUATTROCODE /TRIAX-E	CARBIDE	76°	2,23	40	6	1	124,49
SLLW138	W138	QUATTROCODE /TRIAX-E	CARBIDE	90°	4x0,7*	48	6	2	92,86
SLLW139	W139	QUATTROCODE /TRIAX-E	CARBIDE	60°/50°	0,9	40	6	2	138,52
SLLW142	W142	QUATTROCODE /TRIAX-E	CARBIDE	100°	1,2	40	6	2	92,86
SLLW145	W145	QUATTROCODE /TRIAX-E	CARBIDE	90°	3,2x0,8*	48	6	2	124,42
SLLW210	W210	QUATTROCODE /TRIAX-E	CARBIDE	90°	5x1,05*	40	6	3	186,33
SLLW213	W213	QUATTROCODE /TRIAX-E	CARBIDE	90°	0,95*	40	6	2	140,21
SLLW221	W221	QUATTROCODE /TRIAX-E	CARBIDE	90°	0,5	40	6	2	125,01
SLLW225	W225	QUATTROCODE /TRIAX-E	CARBIDE	90°	1	40	6	2	125,01
SLLW238	W238	QUATTROCODE /TRIAX-E	CARBIDE	90°	0,8	40	6	2	92,86
SLLW261	W261	QUATTROCODE /TRIAX-E	CARBIDE	1,1	3x1,5*	48	6	2	140,21
SLLW255	W255	QUATTROCODE /TRIAX-E	CARBIDE	90°	4x0,8*	48	6	2	125,01
SLLW293	W293	QUATTROCODE /TRIAX-E	CARBIDE	90°	0,85	40	6	2	125,01
SLLW299	W299	QUATTROCODE /TRIAX-E	CARBIDE	90°	3x0,80	40	6	2	100,72

* \varnothing_1 x \varnothing_1

CUTTERS FOR SILCA KEY DUPLICATING MACHINES

DIMPLE CUTTERS

QUATTROCODE / TRIAX-E

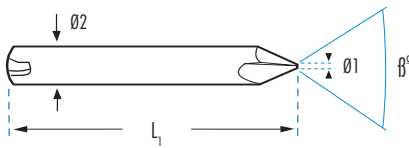

Ref. SLLW103Z1

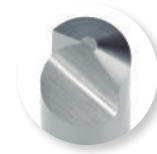

Ref. BM	Ref. SILCA	MACHINE TYPES	MATERIAL	β°	\emptyset_1 mm	L_1 mm	\emptyset_2 mm	Z	€
SLLW102Z1	W102 Z1	QUATTROCODE / TRIAX-E	CARBIDE	106°	1	40	6	2	93,46
SLLW103Z1	W103 Z1	QUATTROCODE / TRIAX-E	CARBIDE	90°	0,8	40	6	2	93,46
SLLW104Z1	W104 Z1	QUATTROCODE / TRIAX-E	CARBIDE	90°	1,2	40	6	2	93,46
SLLW105Z1	W105 Z1	QUATTROCODE / TRIAX-E	CARBIDE	90°	0,7	40	6	2	93,46
SLLW106Z1	W106 Z1	QUATTROCODE / TRIAX-E	CARBIDE	90°	0,6	40	6	2	93,46
SLLW107Z1	W107 Z1	QUATTROCODE / TRIAX-E	CARBIDE	90°	0,9	40	6	2	93,46
SLLW108Z1	W108 Z1	QUATTROCODE / TRIAX-E	CARBIDE	82°	0,9	40	6	2	93,46
SLLW109Z1	W109 Z1	QUATTROCODE / TRIAX-E	CARBIDE	110°	0,4	40	6	2	93,46
SLLW113Z1	W113 Z1	QUATTROCODE / TRIAX-E	CARBIDE	100°	0,76	40	6	2	93,46
SLLW116Z1	W116 Z1	QUATTROCODE / TRIAX-E	CARBIDE	90°	1	40	6	2	93,46
SLLW118Z1	W118 Z1	QUATTROCODE / TRIAX-E	CARBIDE	120°	0,6	40	6	2	93,46
SLLW119Z1	W119 Z1	QUATTROCODE / TRIAX-E	CARBIDE	85°	0,3	40	6	2	93,46
SLLW122Z1	W122 Z1	QUATTROCODE / TRIAX-E	CARBIDE	90°	0,55	40	6	2	93,46
SLLW123Z1	W123 Z1	QUATTROCODE / TRIAX-E	CARBIDE	76°	0,9	40	6	2	93,46
SLLW146Z1	W146 Z1	QUATTROCODE / TRIAX-E	CARBIDE	90°	0,25	40	6	1	93,46

DIMPLE CUTTERS

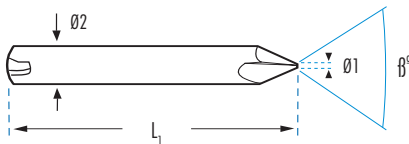

Ref. SLLH103

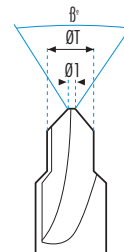
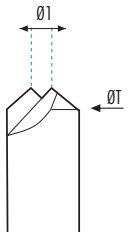

Ref. SLLH115

Ref. SLLH111
Ref. SLLH126
Ref. SLLH127

Ref. BM	Ref. SILCA	UNIV.	MACHINE TYPES	MATERIAL	β°	\emptyset_1 mm	L_1 mm	\emptyset_2 mm	Z	€
SLLH103	H103	FLLF1	QUATTROCODE / TRIAX-E	HSSV	90°	0,8	40	6	2	68,52
SLLH104	H104	FLLF1	QUATTROCODE / TRIAX-E	HSSV	90°	1,2	40	6	2	61,20
SLLH105	H105	FLLF1	QUATTROCODE / TRIAX-E	HSSV	90°	0,7	40	6	2	61,20
SLLH106	H106	FLLF1	QUATTROCODE / TRIAX-E	HSSV	90°	0,6	40	6	2	58,00
SLLH107	H107	FLLF1	QUATTROCODE / TRIAX-E	HSSV	90°	0,9	40	6	2	58,00
SLLH108	H108	FLLF82	QUATTROCODE / TRIAX-E	HSSV	82°	0,9	40	6	2	58,00
SLLH110	H110	FLLF13	QUATTROCODE / TRIAX-E	HSSV	100°	0,6	40	6	2	58,00
SLLH111	H111	FLLF95	QUATTROCODE / TRIAX-E	HSSV	96°	6,4x2,75*	40	6	2	58,00
SLLH112	H112	-	QUATTROCODE / TRIAX-E	HSSV	60°	1,5	40	6	2	58,00
SLLH113	H113	FLLF13	QUATTROCODE / TRIAX-E	HSSV	100°	0,76	40	6	2	58,00
SLLH115	H115	-	QUATTROCODE / TRIAX-E	HSSV	54°	4x0,86*	40	6	1	58,00
SLLH116	H116	FLLF1	QUATTROCODE / TRIAX-E	HSSV	90°	1	40	6	2	76,56
SLLH118	H118	-	QUATTROCODE / TRIAX-E	HSSV	120°	0,6	40	6	1	58,00
SLLH119	H119	FLLF82	QUATTROCODE / TRIAX-E	HSSV	85°	0,3	40	6	2	58,00
SLLH122	H122	FLLF1	QUATTROCODE / TRIAX-E	HSSV	90°	0,55	40	6	2	58,00
SLLH126	H126	FLLF85	QUATTROCODE / TRIAX-E	HSSV	80°	3,3*	48	6	2	86,57
SLLH127	H127	FLLF85	QUATTROCODE / TRIAX-E	HSSV	80°	2,1*	48	6	2	86,57
SLLH128	H128	FLLF1	QUATTROCODE / TRIAX-E	HSSV	90°	0,75	48	6	2	58,00

* $\emptyset_1 \times \emptyset_1$

CUTTERS FOR SILCA KEY DUPLICATING MACHINES

LASER CUTTERS

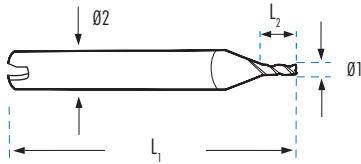

Ref. SLLH101



Ref. BM	Ref. SILCA	MACHINE TYPES	MATERIAL	Ø1 mm	L1 mm	Ø2 mm	L2 mm	Z	SLL €
SLLH101	H101	QUATTROCODE /TRIAX-E	HSSV	2,5	40	6	6	3	68,13
SLLH114	H114	QUATTROCODE /TRIAX-E	HSSV	2	40	6	6	3	58,00
SLLH117	H117	QUATTROCODE /TRIAX-E	HSSV	5	48	6	R1	4	70,37
SLLH129	H129	QUATTROCODE /TRIAX-E	HSSV	3	40	6	6	3	58,00
SLLH131	H131	QUATTROCODE /TRIAX-E	HSSV	6	40	6	5	3	76,56

TRACER POINTS

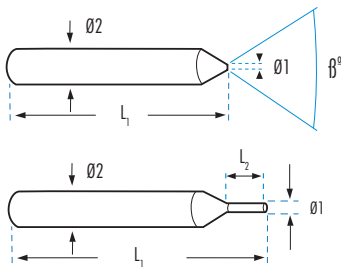

Ref. SLLT1



Ref. SLLT3



Ref. BM	Ref. SILCA	MACHINE TYPES	Ref. CUTTER	MATERIAL	β°	Ø1 mm	L1 mm	Ø2 mm	L2 mm	ØT mm	SLL €
SLLT1	T1	MATRIX	F1	HSSV	90°	0,7	48	6	-	-	40,50
SLLT2	T2	MATRIX	F2	HSSV	88°	1,6	48	6	-	-	45,61
SLLT3	T3	MATRIX	F3	HSSV	-	1,5	48	6	3	-	45,61
SLLT4	T4	MATRIX	F4	HSSV	90°	0,4	48	6	-	-	45,61
SLLT5	T5	MATRIX	F5	HSSV	90°	0,9	48	6	-	-	45,61
SLLT6	T6	MATRIX	F6	HSSV	106°	1	48	6	15	-	45,61
SLLT7	T7	MATRIX	F7	HSSV	72°	0,8	48	6	2	-	45,61
SLLT8	T8	MATRIX	F8	HSSV	-	4	48	6	12	-	45,61
SLLT11	T11	MATRIX	F11	HSSV	-	2,5	48	6	6	-	45,61
SLLT12A	T12A	MATRIX	F12A	HSSV	100°	0,4	48	6	-	-	45,61
SLLT12B	T12B	MATRIX	F12B	HSSV	90°	2,8	48	6	-	-	45,61
SLLT13	T13	MATRIX	F13	HSSV	90°	0,77	48	6	-	-	45,61
SLLT14	T14	MATRIX	F14	HSSV	90°	0,9	48	6	-	-	45,61
SLLT15	T15	MATRIX	F15	HSSV	90°	0,8	48	6	-	-	45,61
SLLT19	T19	MATRIX	F19	HSSV	90°	2,2 x 0,6*	48	6	-	-	45,61
SLLT20	T20	MATRIX	F20	HSSV	90°	0,45	48	6	-	-	45,61
SLLT21	T21	MATRIX	F21	HSSV	85°	3,2 x 0,8*	48	6	-	-	45,61
SLLT22	T22	MATRIX	F22	HSSV	-	2,5	42	6	6	-	45,61
SLLT23	T23	MATRIX	F23	HSSV	90°	1,5	48	6	5	-	45,61

CUTTERS FOR SILCA KEY DUPLICATING MACHINES

TRACER POINTS

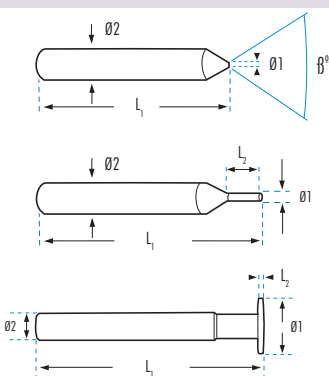

*Ref. SLLT62W



Ref. SLLT1



Ref. SLLT3



SLL

Ref. BM	Ref. SILCA	MACHINE TYPES	Ref. CUTTER	MATERIAL	β°	\varnothing_1 mm	L ₁ mm	\varnothing_2 mm	L ₂ mm	\varnothing_T mm	€
SLLT24	T24	MATRIX	F24	HSSV	100°	1,3	48	6	-	-	45,61
SLLT25	T25	MATRIX	F25	HSSV	90°	3,5 x 0,65*	48	6	-	-	45,61
SLLT26	T26	MATRIX	F26	HSSV	82°	0,8	48	6	-	-	45,61
SLLT27	T27	MATRIX	F27	HSSV	60°	1,28	48	6	-	-	51,49
SLLT28	T28	MATRIX	F28	HSSV	76°	0,76	48	6	-	-	45,61
SLLT29	T29	MATRIX	F29	HSSV	76°	1,9	48	6	-	-	45,61
SLLT30	T30	MATRIX	F30	HSSV	-	3	48	6	10	-	45,61
SLLT30-45	T30-45	MATRIX		HSSV	-	3	45	6	10	-	45,61
SLLT33	T33	MATRIX	F33	HSSV	48°	1,4	48	6	-	-	68,01
SLLT34	T34	MATRIX	F34	HSSV	50°	1,5	48	6	-	-	45,61
SLLT37	T37	MATRIX	F37	HSSV	90°	2,1	48	6	-	-	45,61
SLLT39	T39	MATRIX	F39	HSSV	90°	0,6	48	6	-	-	45,61
SLLT40	T40	MATRIX	F40	HSSV	108°	0,4	48	6	-	-	45,61
SLLT42	T42	MATRIX	F42	HSSV	100°	0,7	48	6	-	-	45,61
SLLT43	T43	MATRIX	F43	HSSV	90°	1	48	6	-	-	45,61
SLLT44	T44	MATRIX	F44	HSSV	-	2	48	6	8	-	45,61
SLLT44-45	T44-45	MATRIX		HSSV	-	2	45	6	8	-	45,61
SLLT46	T46	MATRIX	F46	HSSV	100°	0,65	48	6	-	-	45,61
SLLT49	T49	MATRIX	F49	HSSV	95°	0,8	48	6	-	-	45,61
SLLT50	T50	MATRIX	F50	HSSV	100°	0,5	48	6	-	-	45,61
SLLT52	T52	MATRIX	F52	HSSV	54°	0,86	48	6	6	2	45,61
SLLT54	T54	MATRIX	F54	HSSV	-	4	40	6	6,5	-	58,00
SLLT55	T55	MATRIX	F55	HSSV	100°	1	48	6	4	-	45,61
SLLT59	T59	MATRIX	F59	HSSV	90°	0,8	48	6	-	-	45,61
SLLT62W*	T62W	MATRIX	F62W	CARBIDE	-	11,8	48	6	1	-	91,07
SLLT63	T63	MATRIX	F63	HSSV	78°	0,5	48	6	4	3	45,61
SLLT65	T65	MATRIX	F65	HSSV	90°	1,05	48	6	5	3	45,61
SLLT101	T101	MATRIX		HSSV	-	2,5	40	6	6	-	45,61
SLLT129	T129	MATRIX		HSSV	-	3	40	6	10	-	45,61
SLLU101	U101	QUATTROCODE		CARBIDE	-	1,2	48	6	3	-	58,00
SLLU101/H	U101/H	QUATTROCODE /TRIAX-E		CARBIDE	-	1,2	48	6	3	-	39,41
SLLU102/65	U102/65	QUATTROCODE /TRIAX-E		CARBIDE	30°	0,2	48	6	9	2,6	61,95
SLLU102TT	U102TT	QUATTROCODE /TRIAX-E		CARBIDE	30°	0,2	26	4	6	2	61,95
SLLU103	U103	QUATTROCODE /TRIAX-E		CARBIDE	-	1	48	6	3	-	58,00
SLLU103/H	U103/H	QUATTROCODE /TRIAX-E		CARBIDE	-	1	48	6	3	-	39,41
SLLU103-TT	U103-TT	QUATTROCODE /TRIAX-E		CARBIDE	-	1	21	4	3	-	58,00
SLLU103-TT/H	U103-TT/H	QUATTROCODE /TRIAX-E		CARBIDE	-	1	21	4	3	-	39,41
SLLU111	U111	SILCA VIPER		CARBIDE	-	1	40	6	2,2	-	58,00
SLLU111/H	U111/H	SILCA VIPER		CARBIDE	-	1	40	6	2,2	-	39,41
SLLB3304	B3304	KEYLINE BIANCHI 994 LASER		CARBIDE	-	1	33	6	6	-	58,02
SLLB3310	B3310	KEYLINE BIANCHI 994 LASER		CARBIDE	-	1	30	6	2,6	-	58,02
SLLB3310M2	B3310	KEYLINE BIANCHI 994 LASER		HSSV	-	1	30	6	2,6	-	42,98