

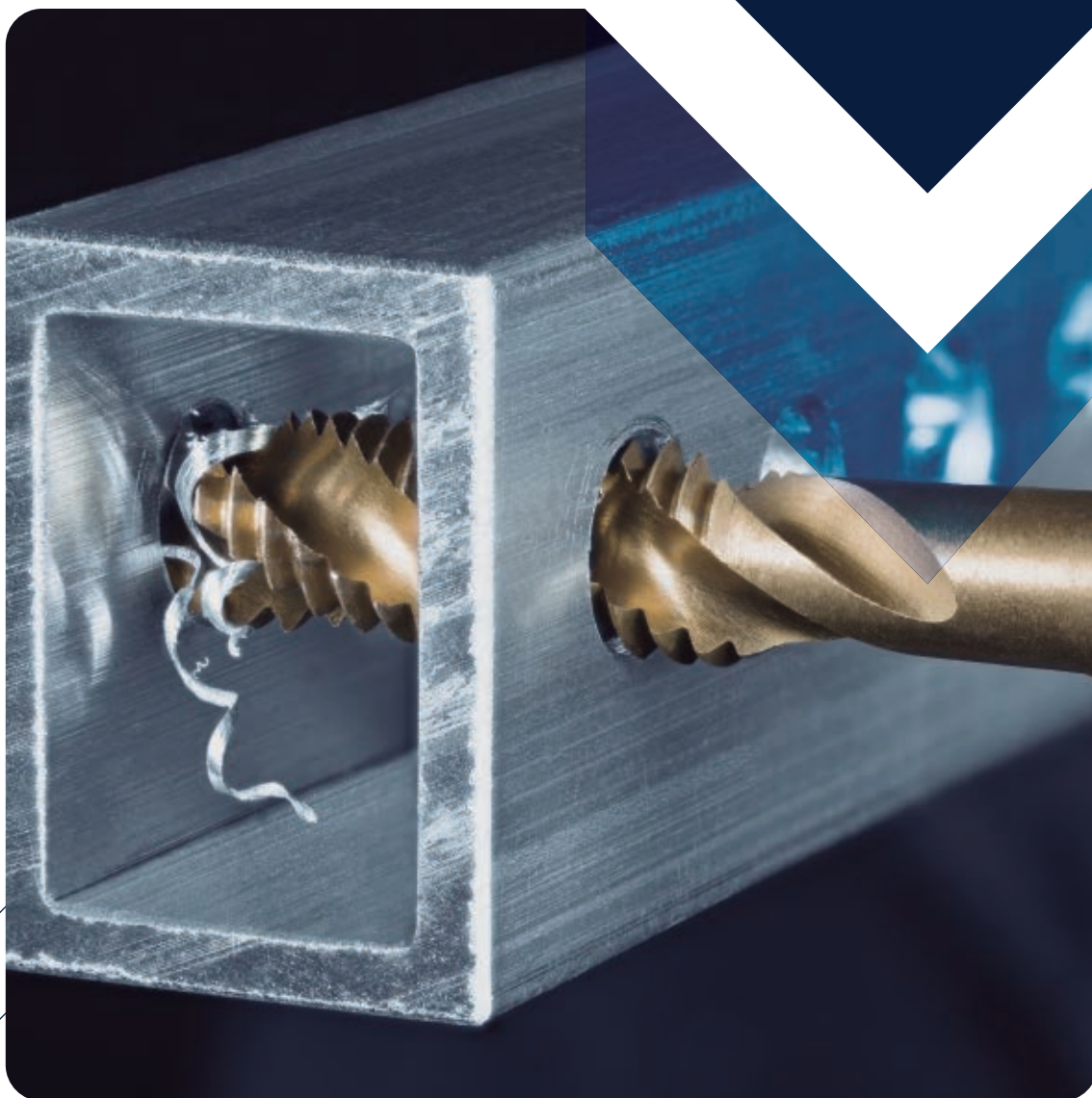

BLUE-MASTER[®]
by *ce/esa*



MASCHI
E FILIERE

SERIE DI MASCHI E FILIERE PER FILETTARE A MANO HSS

Maschi e Filiere

Verde

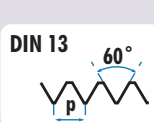

Ref. M0

HSS

(M)

DIN
352

(MF)

DIN
2181TOL
6H

Ref. C5

HSS

DIN
223TOL
6g

Per materiali fino a 38 HRC.

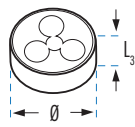
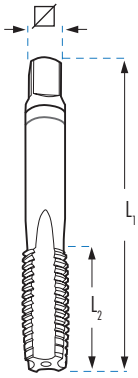

U.tà	Ø	L1 x L2 x mm	M0		C5	
			€	Ø x L3 mm	€	
M 5,5x0,90	3	4,60	50 x 16 x 4,9	85,98	25 x 9	24,84
M 6x0,50	2	5,50	50 x 14 x 4,9	27,77	20 x 5	30,60
M 6x0,75	2	5,25	50 x 14 x 4,9	23,39	25 x 9	27,39
M 6x1,00	3	5,00	50 x 19 x 4,9	17,10*	25 x 9	19,30*
M 6x1,25	3	4,75	50 x 19 x 4,9	134,35	25 x 9	108,33
M 7x0,75	2	6,25	50 x 14 x 4,9	28,35	25 x 9	32,33
M 7x1,00	3	6,00	50 x 19 x 4,9	22,54*	25 x 9	25,52*
M 7x1,25	3	5,75	50 x 19 x 4,9	98,01	25 x 9	130,19
M 8x0,50	2	7,50	50 x 16 x 4,9	33,30	25 x 9	32,33
M 8x0,75	2	7,25	50 x 16 x 4,9	28,75	25 x 9	27,80
M 8x1,00	2	7,00	56 x 18 x 4,9	21,26*	25 x 9	27,80*
M 8x1,25	3	6,80	56 x 22 x 4,9	18,69*	25 x 9	19,71*
M 8x1,50	3	6,50	56 x 22 x 4,9	95,35	25 x 9	116,42
M 9x1,00	2	8,00	63 x 18 x 5,5	31,49	25 x 9	39,21
M 9x1,25	3	7,80	63 x 22 x 5,5	25,37*	25 x 9	29,12*
M 10x0,50	2	9,50	63 x 18 x 5,5	51,07	30 x 10	94,01
M 10x0,75	2	9,25	63 x 18 x 5,5	44,33	30 x 11	39,22
M 10x1,00	2	9,00	63 x 18 x 5,5	25,01	38 x 10	32,33
M 10x1,25	2	8,80	70 x 24 x 5,5	23,29	38 x 10	32,34
M 10x1,50	3	8,50	70 x 24 x 5,5	24,07*	38 x 10	22,56*
M 11x0,75	2	10,25	63 x 18 x 6,2	80,48	30 x 11	128,97
M 11x1,00	2	10,00	63 x 18 x 6,2	40,99	30 x 11	44,02
M 11x1,25	2	9,75	63 x 20 x 6,2	40,99	30 x 11	45,15
M 11x1,50	3	9,50	70 x 24 x 6,2	51,49	38 x 10	33,25
M 12x0,75	2	11,25	70 x 20 x 7,0	40,72	38 x 10	45,76
M 12x1,00	2	11,00	70 x 20 x 7,0	40,97	38 x 10	39,21
M 12x1,25	2	10,75	70 x 20 x 7,0	40,84	38 x 10	39,21
M 12x1,50	2	10,50	70 x 20 x 7,0	37,68*	38 x 10	38,18*
M 12x1,75	3	10,20	75 x 29 x 7,0	30,33*	38 x 14	32,64*
M 13x0,75	2	12,25	70 x 20 x 9,0	82,71	38 x 10	121,66
M 13x1,00	2	12,00	70 x 20 x 9,0	63,98	38 x 10	50,20
M 13x1,25	2	11,75	70 x 20 x 9,0	66,02	38 x 10	83,39
M 13x1,50	2	11,50	70 x 20 x 9,0	62,91	38 x 10	50,17
M 13x1,75	3	11,25	70 x 20 x 9,0	81,68	38 x 14	75,67
M 14x0,75	2	13,25	70 x 20 x 9,0	64,26	38 x 10	51,51
M 14x1,00	2	13,00	70 x 20 x 9,0	63,63	38 x 10	49,57
M 14x1,25	2	12,80	70 x 20 x 9,0	47,47*	38 x 10	44,13*
M 14x1,50	2	12,50	70 x 20 x 9,0	40,67	38 x 10	44,13
M 14x1,75	2	12,25	70 x 20 x 9,0	83,51	38 x 14	187,47
M 14x2,00	3	12,00	80 x 30 x 9,0	39,05*	38 x 14	35,61*
M 15x1,00	2	14,00	70 x 20 x 9,0	68,99	45 x 14	66,76
M 15x1,25	2	13,75	70 x 20 x 9,0	98,51	45 x 14	113,94
M 15x1,50	2	13,50	70 x 20 x 9,0	69,67	45 x 14	64,19
M 15x2,00	3	13,00	80 x 30 x 9,0	100,91	45 x 14	98,63
M 16x1,00	2	15,00	70 x 20 x 9,0	69,40	45 x 14	64,18
M 16x1,25	2	14,75	70 x 20 x 9,0	69,82	45 x 14	68,59
M 16x1,50	2	14,50	70 x 20 x 9,0	50,01*	45 x 14	52,33*
M 16x2,00	3	14,00	80 x 32 x 9,0	46,83*	45 x 18	41,77*
M 17x1,00	2	16,00	70 x 20 x 9,0	149,53	45 x 14	116,74
M 17x1,25	2	15,75	70 x 20 x 9,0	149,53	45 x 14	121,42
M 17x1,50	2	15,50	70 x 20 x 9,0	149,53	45 x 14	116,74
M 18x1,00	2	17,00	80 x 22 x 11,0	74,89	45 x 14	60,21
M 18x1,25	2	16,75	80 x 22 x 11,0	77,74	45 x 14	64,34

* Consultare il prezzo delle serie di maschi e filiere a sinistra disponibili a Pag.188

* Sovrapprezzo per le filiere regolabili pari al 20% del prezzo.

SERIE DI MASCHI E FILIERE PER FILETTARE A MANO HSS

M
MF

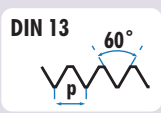

DIN 13
60°

Ref. MO

HSS

DIN
352

DIN
2181





TOL
6H

Ref. C5

HSS

DIN
223

TOL
6g

		(M)					(MF)						
		MO		C5					MO		C5		
	U.ità		L1 x L2 x mm	€	Ø x L3 mm	€		U.ità		L1 x L2 x mm	€	Ø x L3 mm	€
M 18x1,50	2	16,50	80 x 22 x 11,0	51,02	45 x 14	54,42	M 33x3,50	3	29,5	125 x 50 x 20,0	315,78*	65 x 25	118,43*
M 18x2,00	2	16,00	80 x 22 x 11,0	75,58*	45 x 14	61,83*	M 34x1,50	2	32,5	100 x 25 x 22,0	327,32	65 x 18	150,10
M 18x2,50	3	15,50	95 x 40 x 11,0	62,22*	45 x 18	47,44*	M 34x2,00	2	32,0	100 x 25 x 22,0	359,55	65 x 18	342,62
M 19x1,00	2	18,00	80 x 22 x 11,0	217,00	45 x 14	147,59	M 35x1,50	2	33,5	100 x 25 x 22,0	314,81	65 x 18	141,37
M 19x1,25	2	17,75	80 x 22 x 11,0	217,00	45 x 14	173,60	M 35x2,00	2	33,0	100 x 25 x 22,0	396,48	65 x 18	285,90
M 19x1,50	2	17,50	80 x 22 x 11,0	217,00	45 x 14	147,59	M 36x1,50	2	34,5	100 x 25 x 22,0	350,85	65 x 18	141,38
M 19x2,00	2	17,00	80 x 22 x 11,0	241,64	45 x 14	175,35	M 36x2,00	2	34,0	125 x 33 x 22,0	393,10	65 x 18	141,38
M 20x1,00	2	19,00	80 x 22 x 12,0	97,32	45 x 14	60,21	M 36x3,00	2	33,0	125 x 33 x 22,0	427,88*	65 x 25	141,37*
M 20x1,25	2	18,75	80 x 22 x 12,0	92,96	45 x 14	178,32	M 36x4,00	3	32,0	150 x 53 x 22,0	391,73*	65 x 25	118,46*
M 20x1,50	2	18,50	80 x 22 x 12,0	55,27	45 x 14	52,95	M 38x1,50	2	36,5	100 x 25 x 22,0	405,50	75 x 20	227,93
M 20x2,00	2	18,00	80 x 22 x 12,0	97,15*	45 x 14	60,21*	M 38x2,00	2	36,0	125 x 25 x 22,0	491,91	75 x 20	332,74
M 20x2,50	3	17,50	95 x 40 x 12,0	68,68*	45 x 18	46,14*	M 39x1,50	2	37,5	110 x 25 x 24,0	486,98	75 x 20	221,48
M 21x1,00	2	20,00	80 x 22 x 12,0	272,79	45 x 14	74,24	M 39x2,00	2	37,0	125 x 23 x 24,0	486,98	75 x 20	221,46
M 21x1,25	2	19,75	80 x 22 x 12,0	272,79	45 x 14	188,04	M 39x3,00	2	36,0	125 x 33 x 24,0	481,49*	75 x 30	221,48*
M 21x1,50	2	19,50	80 x 22 x 12,0	107,37	45 x 14	94,19	M 39x4,00	3	35,0	150 x 53 x 24,0	443,31*	75 x 30	183,58*
M 22x1,00	2	21,00	80 x 22 x 14,5	96,94	55 x 16	110,60	M 40x1,50	2	38,5	110 x 25 x 24,0	476,20	75 x 20	252,16
M 22x1,25	2	20,75	80 x 22 x 14,5	110,94	55 x 16	180,24	M 40x2,00	2	38,0	125 x 33 x 24,0	475,83	75 x 20	258,29
M 22x1,50	2	20,50	80 x 22 x 14,5	80,66	55 x 16	95,14	M 40x3,00	2	37,0	125 x 33 x 24,0	474,07	75 x 30	221,46
M 22x2,00	2	20,00	80 x 22 x 14,5	94,26*	55 x 16	105,86*	M 42x1,50	2	40,5	110 x 25 x 24,0	475,54	75 x 20	221,48
M 22x2,50	3	19,50	100 x 40 x 14,5	96,05*	55 x 22	84,62*	M 42x2,00	2	40,0	125 x 33 x 24,0	508,05	75 x 20	172,69
M 23x1,00	2	22,00	80 x 22 x 14,5	280,43	55 x 16	195,56	M 42x3,00	2	39,0	125 x 33 x 24,0	503,26	75 x 30	221,48
M 23x1,50	2	21,50	80 x 22 x 14,5	126,26	55 x 16	216,67	M 42x4,50	3	37,5	150 x 53 x 24,0	622,17	75 x 30	183,59
M 24x1,00	2	23,00	90 x 22 x 14,5	124,64	55 x 16	107,87	M 45x1,50	2	43,5	110 x 25 x 29,0	549,82	90 x 22	353,85
M 24x1,25	2	22,75	90 x 22 x 14,5	125,80	55 x 16	143,21	M 45x2,00	2	43,0	125 x 33 x 29,0	559,98	90 x 22	351,31
M 24x1,50	2	22,50	90 x 22 x 14,5	95,51	55 x 16	96,94	M 45x3,00	2	42,0	125 x 33 x 29,0	559,98	90 x 36	351,28
M 24x2,00	2	22,00	90 x 22 x 14,5	128,44*	55 x 16	107,87*	M 45x4,50	3	40,5	160 x 60 x 29,0	718,25	90 x 36	316,75
M 24x3,00	3	21,00	110 x 50 x 14,5	111,29*	55 x 22	84,62*	M 48x1,50	2	46,5	140 x 33 x 29,0	619,63	90 x 22	351,31
M 25x1,00	2	24,00	90 x 22 x 14,5	187,09	55 x 16	163,71	M 48x2,00	2	46,0	140 x 33 x 29,0	677,25	90 x 22	351,30
M 25x1,25	2	23,75	90 x 22 x 14,5	328,70	55 x 16	215,55	M 48x3,00	2	45,0	140 x 33 x 29,0	678,59	90 x 36	351,28
M 25x1,50	2	23,50	90 x 22 x 14,5	193,92	55 x 16	140,82	M 48x5,00	3	43,0	180 x 65 x 29,0	821,55	90 x 36	304,58
M 25x2,00	2	23,00	90 x 22 x 14,5	388,97	55 x 16	209,57	M 50x1,50	2	48,5	140 x 33 x 29,0	671,32	90 x 22	353,85
M 26x1,00	2	25,00	90 x 22 x 14,5	188,45	55 x 16	162,26	M 50x3,00	2	57,0	140 x 33 x 29,0	721,45	90 x 22	339,49
M 26x1,50	2	24,50	90 x 22 x 14,5	182,77	55 x 16	130,81	M 52x1,50	2	50,5	140 x 33 x 32,0	705,65	90 x 22	318,09
M 26x2,00	2	24,00	90 x 22 x 14,5	189,29	55 x 16	183,36	M 52x2,00	2	50,0	140 x 33 x 32,0	869,88	90 x 22	369,66
M 27x1,00	2	26,00	90 x 22 x 16,0	189,31	65 x 18	145,96	M 52x3,00	2	49,0	140 x 33 x 32,0	877,67	90 x 36	403,40
M 27x1,50	2	25,50	90 x 22 x 16,0	192,82	65 x 18	146,59	M 52x5,00	3	47,0	180 x 65 x 32,0	1.040,83	90 x 36	315,49
M 27x2,00	2	25,00	90 x 22 x 16,0	230,07*	65 x 18	159,43*	M 56x4,00	2	52,0	180 x 47 x 32,0	1.031,04	105 x 36	
M 27x3,00	3	24,00	110 x 50 x 16,0	144,87*	65 x 25	128,35*	M 56x5,50	3	50,5	200 x 85 x 35,0	1.376,26	105 x 36	
M 28x1,00	2	27,00	90 x 22 x 16,0	227,61	65 x 18	188,68	M 60x5,50	3	54,5	200 x 85 x 35,0	1.790,02	105 x 36	
M 28x1,50	2	26,50	90 x 22 x 16,0	203,06	65 x 18	132,89	M 64x4,00	2	60,0	180 x 50 x 35,0	1.683,20	120 x 36	
M 28x2,00	2	26,00	90 x 22 x 16,0	226,30	65 x 18	186,83	M 64x6,00	3	58,0	220 x 90 x 39,0	2.078,47	120 x 36	
M 30x1,00	2	29,00	90 x 22 x 18,0	227,62	65 x 18	154,68	M 68x6,00	3	62,0	220 x 90 x 39,0	2.535,73	120 x 36	
M 30x1,50	2	28,50	90 x 22 x 18,0	216,40	65 x 18	157,08	M 72x6,00	3	66,0	235 x 90 x 39,0	2.747,16	120 x 36	
M 30x2,00	2	28,00	90 x 22 x 18,0	249,48	65 x 18	141,38							
M 30x3,00	2	27,00	125 x 56 x 18,0	243,88*	65 x 25	113,39*							
M 30x3,50	3	26,50	125 x 50 x 18,0	183,58*	65 x 25	118,46*							
M 32x1,00	2	31,00	90 x 22 x 18,0	332,84	65 x 18	213,78							
M 32x1,50	2	30,50	90 x 22 x 18,0	267,12	65 x 18	141,37							
M 32x2,00	2	30,00	90 x 22 x 18,0	333,40	65 x 18	113,40							
M 33x1,00	2	32,00	100 x 25 x 20,0	505,88	65 x 18	230,99							
M 33x1,50	2	31,50	100 x 25 x 20,0	275,56	65 x 18	145,43							
M 33x2,00	2	31,00	100 x 25 x 20,0	370,90	65 x 18	145,43							
M 33x3,00	2	30,00	125 x 56 x 20,0	429,96*	65 x 25	133,40*							

FILIERE CON MISURA ESTERNA IN POLLICI					
			C5		
	Ø x L3 mm	€		Ø x L3 mm	€
M 3x0,50	25,4 x 9,5	23,63	M 8x1,25	38,1 x 12,7	32,14
M 4x0,70	25,4 x 9,5	23,63	M 10x1,50	25,4 x 9,50	29,70
M 5x0,80	25,4 x 9,5	23,45	M 10x1,50	38,1 x 12,7	39,86
M 6x1,00	25,4 x 9,5	23,63	M 12x1,75	25,4 x 9,50	29,42
M 8x1,25	25,4 x 9,5	23,66	M 12x1,75	38,1 x 12,7	40,20

* Consultare il prezzo delle serie di maschi e filiere a sinistra disponibili a Pag.188
* Sovrapprezzo per le filiere regolabili pari al 20% del prezzo.

SERIE DI MASCHI E FILIERE PER FILETTARE A MANO HSS

UNC

Ref. M0

HSS

DIN
351TOL
2B

Ref. C5

HSS

DIN
223TOL
2a

UNF

Ref. M0

HSS

DIN
2181TOL
2B

Ref. C5

HSS

DIN
223TOL
2a

Icona	U.tà	D1 mm	Ø	L1 x L2 x mm	M0		C5	
					€	Ø x L3 mm	€	€
UNC n°1-64h.	3	1,85	1,50	36x8x2,1	116,08	16x5		
UNC n°2-56h.	3	2,18	1,80	36x9x2,1	82,03	16x5		
UNC n°3-48h.	3	2,51	2,10	40x9x2,1	82,03	16x5		
UNC n°4-40h.	3	2,84	2,25	40x11x2,7	60,29	20x5	38,91	
UNC n°5-40h.	3	3,17	2,60	40x11x2,7	60,52	20x5	38,91	
UNC n°6-32h.	3	3,50	2,75	45x13x3,0	60,52	20x7	38,91	
UNC n°8-32h.	3	4,17	3,50	45x13x3,4	60,52	20x7	38,91	
UNC n°10-24h.	3	4,83	3,90	50x16x4,9	60,52	20x7	38,91	
UNC n°12-24h.	3	5,49	4,50	50x19x4,9	60,52	20x7	38,91	
UNC 1/4-20h.	3	6,35	5,10	50x19x4,9	32,60*	20x7	32,52*	
UNC 5/16-18h.	3	7,94	6,60	56x22x4,9	35,89*	25x9	36,01*	
UNC 3/8-16h.	3	9,52	8,00	70x24x5,5	40,19*	30x11	38,00*	
UNC 7/16-14h.	3	11,11	9,40	70x24x6,2	49,84	38x14	43,81	
UNC 1/2-13h.	3	12,70	10,75	75x29x7,0	66,92*	38x14	48,77*	
UNC 9/16-12h.	3	14,28	12,20	80x30x9,0	78,99	38x14	53,85	
UNC 5/8-11h.	3	15,87	13,50	80x32x9,0	89,50*	45x18	53,66*	
UNC 3/4-10h.	3	19,05	16,50	95x40x11,0	118,75*	45x18	62,97*	
UNC 7/8-9h.	3	22,22	19,50	100x40x14,5	146,19	55x22	93,42	
UNC 1.1/4-7h.	3	25,40	22,25	110x50x14,5	176,26*	55x22	93,42*	
UNC 1.1/8-7h.	3	28,57	25,00	125x56x18,0	361,43	65x25	151,42	
UNC 1.1/4-7h.	3	31,75	28,00	125x56x18,0	428,17	65x25	151,42	
UNC 1.3/8-6h.	3	34,92	30,75	150x63x22,0	661,99	65x25	151,42	
UNC 1.1/2-6h.	3	38,10	34,00	150x63x24,0	646,08	75x30	151,43	
UNC 2"-4,5h.	3	50,80	45,00	180x75x32,0	1.324,27	90x36		

Icona	U.tà	D1 mm	Ø	L1 x L2 x mm	M0		C5	
					€	Ø x L3 mm	€	€
UNF n°2-64h.	2	2,18	1,85	36x8x2,1	72,14			
UNF n°3-56h.	2	2,51	2,15	40x9x2,1	61,34			
UNF n°4-48h.	2	2,84	2,35	40x9x2,7	36,87	20x5	38,91	
UNF n°5-44h.	2	3,17	2,70	45x10x2,7	36,87	20x5	38,91	
UNF n°6-40h.	2	3,50	2,95	45x16x3,0	36,51	20x5	38,91	
UNF n°8-36h.	2	4,17	3,50	50x12x3,4	36,51	20x7	38,91	
UNF n°10-32h.	2	4,83	4,10	50x12x4,9	36,51	20x7	38,91	
UNF n°12-28h.	2	5,49	4,60	50x12x4,9	36,41	20x7	38,91	
UNF 1/4-28h.	2	6,35	5,50	50x14x4,9	22,30*	25x9	32,52*	
UNF 5/16-24h.	2	7,94	6,90	56x22x4,9	22,11*	25x9	36,03*	
UNF 3/8-24h.	2	9,52	8,50	63x20x5,5	32,02*	38x10	37,40*	
UNF 7/16-20h.	2	11,11	9,90	63x20x6,2	37,12	38x10	43,82	
UNF 1/2-20h.	2	12,70	11,50	70x22x7,0	39,62*	38x10	48,77*	
UNF 9/16-18h.	2	14,29	12,90	70x22x9,0	48,77	38x10	52,64	
UNF 5/8-18h.	2	15,87	14,50	70x22x9,0	55,57*	45x14	53,66*	
UNF 3/4-16h.	2	19,05	17,50	80x22x11,0	72,16*	45x14	62,97*	
UNF 7/8-14h.	2	22,22	20,40	80x22x14,5	95,94*	55x16	93,42*	
UNF 1"-12h.	2	25,40	23,25	90x22x16,0	142,07	55x16	93,42	
UNF 1"-14h.	2	25,40	23,60	90x22x14,5	160,58*	55x16	121,88*	
UNF 1.1/8-12h.	2	28,57	26,50	90x22x18,0	171,33	65x18	151,43	
UNF 1.1/4-12h.	2	31,75	29,50	90x22x20,0	326,28	65x18	151,42	
UNF 1.3/8-12h.	2	34,92	32,80	125x35x22,0	247,50	65x18	151,42	
UNF 1.1/2-12h.	2	38,10	36,00	125x40x22,0	410,37	75x20	237,88	
UNF 2"-12h.	2	50,80	48,38	140x40x29,0	1.289,47	90x22		

* Consultare il prezzo delle serie di maschi e filiere a sinistra disponibili a Pag.188

SERIE DI MASCHI E FILIERE PER FILETTARE A MANO HSS

BSP (GAS) Ref. M0 **DIN 5157** **ISO 228** Ref. C5 **DIN 5158** Ref. MOT Ref. MOX **DIN 5157** **TOL 6H** Ref. CST Ref. C5X **DIN 5158** **TOL 6g**



U.ità	D1 mm	L1 x L2 x mm	M0		C5		MOT		CST		MOX		C5X	
			HSS	€	HSS	€	HSS	€	HSS	€	HSSCo	€	HSSCo	€
G 1/8-28h.	2	9,73	8,80	63 x 20 x 5,5	33,49*	38 x 10	45,28*	G 1/8-28 h.	2	71,43	70,01	82,05	54,39	
G 1/4-19h.	2	13,16	11,80	70 x 22 x 9,0	35,76*	38 x 10	42,43*	G 1/4-19 h.	2	96,73	75,55	109,78	56,89	
G 3/8-19h.	2	16,66	15,25	70 x 22 x 9,0	52,39*	45 x 14	57,45*	G 3/8-19 h.	2	139,15	81,50	160,79	69,36	
G 1/2-14h.	2	20,95	19,00	80 x 22 x 12,0	82,26*	45 x 14	57,45*	G 1/2-14 h.	2	233,36	92,26	258,15	73,86	
G 5/8-14h.	2	22,91	21,00	80 x 22 x 14,5	97,69*	55 x 16	91,12*							
G 3/4-14h.	2	26,44	24,50	90 x 22 x 16,0	120,14*	55 x 16	91,11*	G 3/4-14 h.	2	270,33	150,30	327,17	110,24	
G 7/8-14h.	2	30,20	28,25	90 x 22 x 18,0	192,96	65 x 18	117,18							
G 1"-11h.	2	33,25	30,75	100 x 25 x 20,0	180,07*	65 x 18	117,17*	G 1" -11 h.	2	425,73	200,77	486,25	142,68	
G 1.1/8-11h.	2	37,90	35,50	125 x 40 x 22,0	362,65	75 x 20	181,01							
G 1.1/4-11h.	2	41,91	39,50	125 x 40 x 24,0	289,67*	75 x 20	181,02*							
G 1.3/8-11h.	2	44,32	42,00	125 x 40 x 29,0	480,54	90 x 22	269,32							
G 1.1/2-11h.	2	47,80	45,25	140 x 40 x 29,0	425,94	90 x 22	269,32							
G 1.3/4-11h.	2	53,75	51,25	140 x 40 x 32,0	775,43	105 x 22	280,06							
G 2"-11h.	2	59,61	57,00	160 x 40 x 35,0	693,98	105 x 22	300,75							
G 2.1/4-11h.	2	65,71	63,00	160 x 40 x 39,0	1.632,73	105 x 22								
G 2.1/2-11h.	2	75,18	72,50	160 x 40 x 39,0	1.931,99	120 x 22								
G 2.3/4-11h.	2	81,53	79,00	160 x 40 x 39,0	2.817,62	120 x 22								
G 3"-11h.	2	87,88	85,50	160 x 40 x 39,0	2.932,55	150 x 25								
G 4"-11h.	2	113,03	110,50	180 x 45 x 44,0	4.447,69	180 x 25								

UNF 3B Ref. M0 **HSS** **DIN 2181** **TOL 3B**

U.ità	D1 mm	L1 x L2 x mm	MO-3B		
UNF n°4-48-3B	2	2,84	2,35	40x9x2,7	57,26
UNF n°5-44-3B	2	3,17	2,70	45x10x2,7	57,26
UNF n°6-40-3B	2	3,50	2,95	45x16x3,0	54,53
UNF n°8-36-3B	2	4,17	3,50	50x12x3,4	54,53
UNF n°10-32-3B	2	4,83	4,10	50x12x4,9	54,53
UNF n°12-28-3B	2	5,49	4,60	50x12x4,9	57,26
UNF 1/4-28-3B	2	6,35	5,50	50x14x4,9	41,77
UNF 5/16-24-3B	2	7,94	6,90	56x22x4,9	44,71
UNF 3/8-24-3B	2	9,52	8,50	63x20x5,5	51,62
UNF 7/16-20-3B	2	11,11	9,90	63x20x6,2	68,52
UNF 1/2-20-3B	2	12,70	11,50	70x22x7,0	70,09

* Consultare il prezzo delle serie di maschi e filiere a sinistra disponibili a Pag.188

SERIE DI MASCHI E FILIERE PER FILETTARE A MANO HSS

Maschi e Filiere

Rosa
Verde

BSW

Ref. M0

HSS

DIN 351

TOL Classe 2

Ref. C5

HSS

DIN 223

DIN BS84 55°

BSF

Ref. M0

HSS

DIN 5157

TOL ISO 228

Ref. C5

HSS

DIN 223

DIN BS84 55°

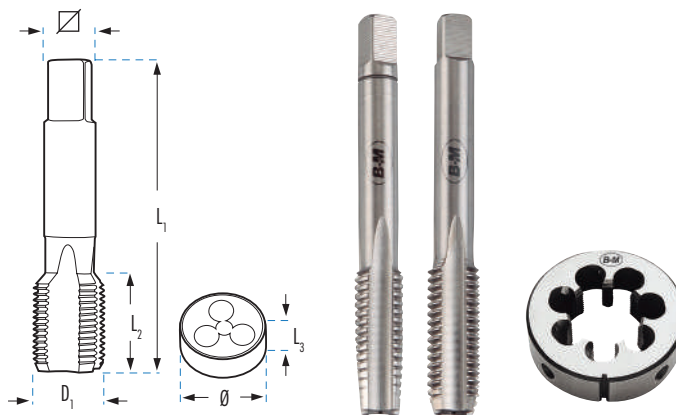

U.tà	D1 mm	Ø	L1 x L2 x L3 mm	M0		C5	
				€	Ø x L3 mm	€	€
W 1/16-60h.	3	1,59	1,15	32x8x2,1	41,49	16x5	83,35
W 3/32-48h.	3	2,38	1,80	40x9x2,1	45,28	20x5	32,23
W 1/8-40h.	3	3,17	2,55	40x14x2,7	32,53*	25x9	32,52*
W 5/32-32h.	3	3,97	3,10	45x17x3,4	30,89	25x9	32,52
W 3/16-24h.	3	4,76	3,60	50x19x4,9	30,90	25x9	32,52
W 7/32-24h.	3	5,55	4,40	50x19x4,9	30,50	25x9	32,53
W 1/4-20h.	3	6,35	5,10	50x20x4,9	30,78*	25x9	32,52*
W 5/16-18h.	3	7,94	6,50	56x20x4,9	35,80*	25x9	36,03*
W 3/8-16h.	3	9,52	7,90	63x22x5,5	44,25*	38x10	38,91*
W 7/16-14h.	3	11,11	9,25	70x22x6,2	47,51	38x10	43,81
W 1/2-12h.	3	12,70	10,50	75x25x7,0	70,11	38x14	48,78
W 9/16-12h.	3	14,29	12,00	80x26x9,0	74,19	38x14	58,05
W 5/8-11h.	3	15,87	13,40	80x27x9,0	85,31*	45x18	58,93*
W 11/16-11h.	3	17,46	15,25	95x32x11,0	251,42	45x18	59,16
W 3/4-10h.	3	19,05	16,50	95x32x11,0	113,55*	45x18	62,99*
W 7/8-9h.	3	22,22	19,25	100x32x14,5	140,01*	55x22	93,41*
W 1" - 8h.	3	25,40	21,75	110x36x14,5	229,66*	55x22	93,41*
W 1.1/8-7h.	3	28,57	24,75	125x40x18,0	289,53	65x25	174,52
W 1.1/4-7h.	3	31,75	27,75	125x40x18,0	321,91	65x25	174,59
W 1.3/8-6h.	3	34,92	30,50	150x50x22,0	441,52	65x25	177,81
W 1.1/2-6h.	3	38,10	33,50	150x50x24,0	496,12	75x30	270,28
W 1.5/8-5h.	3	41,27	46,50	150x56x24,0	892,96	75x30	324,11
W 1.3/4-5h.	3	44,45	39,00	160x58x29,0	900,29	90x36	407,90
W 1.7/8-4,5h.	3	47,62	42,00	180x65x29,0	1.268,49	90x36	446,32
W 2" - 4,5h.	3	50,80	44,50	180x65x32,0	1.410,94	90x36	467,76
W 2.1/4-4h.	3	57,15	50,00	200x85x35,0	2.626,83	105x36	
W 2.1/2-4h.	3	63,50	56,50	220x85x39,0	3.195,59	120x36	
W 2.3/4-3,5h.	3	69,85	62,00	250x90x44,0	4.562,91	120x36	
W 3" - 3,5h.	3	76,20	68,00	250x90x44,0	5.278,79	140x36	

U.tà	D1 mm	Ø	L1 x L2 x L3 mm	M0		C5	
				€	Ø x L3 mm	€	€
BSF 3/16-32h.	2	4,76	4,0	50x19x4,9	30,60	20x7	32,52
BSF 1/4-26h.	2	6,35	5,2	50x20x4,9	30,37	20x7	32,53
BSF 5/16-22h.	2	7,94	6,6	56x20x4,9	30,49	25x9	36,03
BSF 3/8-20h.	2	9,52	8,1	63x22x5,5	42,98	30x11	41,81
BSF 7/16-18h.	2	11,11	9,5	70x22x6,2	40,73	30x11	43,82
BSF 1/2-16h.	2	12,70	11,0	75x25x7,0	57,46	38x10	59,24
BSF 9/16-16h.	2	14,29	12,5	80x26x9,0	74,32	38x10	65,01
BSF 5/8-14h.	2	15,88	14,0	80x26x9,0	71,53	45x14	86,76
BSF 3/4-12h.	2	19,05	16,5	95x33x11,0	98,41	45x14	86,76
BSF 7/8-11h.	2	22,23	19,5	100x33x14,5	112,23	55x22	108,52
BSF 1" - 10h.	2	25,40	22,5	110x40x14,5	150,20	55x22	108,52
BSF 1.1/8-9h.	2	28,57	25,5	110x40x16,0	578,66		
BSF 1.1/4-9h.	2	31,75	28,5	125x46x18,0	660,65		
BSF 1.1/2-8h.	2	38,10	34,5	150x55x22,0	1.006,87		

BSW **INOX** **TiN**

U.tà	L1 x L2 x L3 mm	M0T		C5T	
		€	Ø x L3 mm	€	€
W 3/16-24 h.	3	50 x 19 x 4,90	58,69	25x9	46,33
W 1/4-20 h.	3	50 x 20 x 4,90	58,08	25x9	47,78
W 5/16-18 h.	3	56 x 20 x 4,90	60,61	25x9	54,24
W 3/8-16 h.	3	63 x 22 x 5,50	80,26	38x10	48,69
W 1/2-12 h.	3	75 x 25 x 7,00	124,57	38x14	84,08



* Consultare il prezzo delle serie di maschi e filiere a sinistra disponibili a Pag.188

MASCHI E FILIERE PER FILETTARE A MANO HSS

NPTF

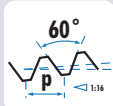

Filettatura AMERICANA
Filettatura conica a tenuta stagna

Ref. MO

HSS

Ref. C5

HSS

DIN 223

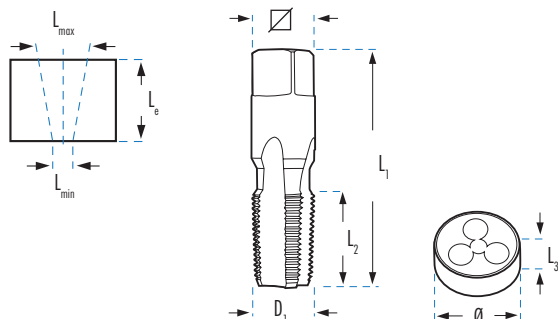

Icona	U.ità	D1 mm	Ø	L min x L max mm	L _e mm	L1 x L2 x mm	MO		C5	
							€	Ø x L3 mm	€	
	1	10,22	8,5	8,30 x 8,76	12,0	54 x 19 x 8,0	90,54	38 x 10	197,73	
	1	13,58	11,0	10,70 x 11,40	17,5	62 x 27 x 11,0	126,90	38 x 15	197,73	
	1	17,02	14,5	14,20 x 14,84	17,6	65 x 27 x 13,0	175,19	45 x 14	258,19	
	1	21,21	17,8	17,40 x 18,33	22,8	80 x 35 x 13,0	244,98	45 x 20	258,19	
	1	26,56	23,0	22,80 x 23,68	23,0	83 x 35 x 17,0	374,47	55 x 22	492,06	
	1	33,19	29,0	28,60 x 29,72	27,4	110 x 38 x 20,0	498,78			

NPT

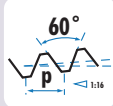

Filettatura AMERICANA
Filettatura conica non a tenuta stagna (Briggs)

Ref. MO

HSS

Ref. C5

HSS

DIN 223

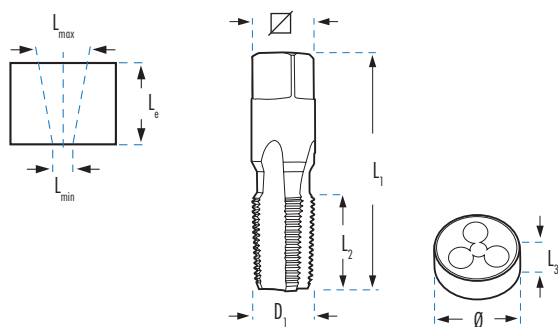

Icona	U.ità	D1 mm	Ø	Icona	L min x L max mm	L _e mm	L1 x L2 x mm	MO		C5	
								€	Ø x L3 mm	€	
	1	7,89	6,20	EMNPT1/16	6,00 x 6,38	12,0	54 x 18 x 6,0	37,89	25 x 9	82,00	
	1	10,24	8,50	EMNPT1/8	8,30 x 8,73	12,0	65 x 19 x 5,5	39,79	30 x 11	88,04	
	1	13,62	11,00	EMNPT1/4	10,70 x 11,35	17,5	62 x 27 x 11,0	55,83	38 x 14	104,41	
	1	17,05	14,50	EMNPT3/8	14,20 x 14,80	17,6	65 x 27 x 13,0	77,03	45 x 18	130,26	
	1	21,23	17,80	EMNPT1/2	17,40 x 18,32	22,8	80 x 35 x 13,0	107,71	45 x 18	135,47	
	1	26,57	23,00	-	22,80 x 23,66	23,0	83 x 35 x 17,0	164,68	55 x 22	204,93	
	1	33,23	29,00	-	28,60 x 29,69	27,4	95 x 44 x 21,0	183,40	65 x 25	296,84	
	1	41,98	37,50	-	37,40 x 38,45	28,1	125 x 33 x 24,0	300,69	75 x 26	346,98	
	1	48,05	44,00	-	43,40 x 44,52	28,4	140 x 33 x 29,0	456,91	90 x 27	484,07	
	1	60,09	56,00	-	55,50 x 56,56	28,4	160 x 33 x 35,0	713,32	105 x 36	673,96	
	1	73,03	67,00	-	68,68 x 69,08	28,9	200 x 45 x 39,0	879,98			
	1	88,90	82,00	-	84,45 x 84,86	30,5	220 x 48 x 39,0	1.236,91			

* Vedi alesatore precedente a pag. 137

MASCHI E FILIERE PER FILETTARE A MANO HSS

PG

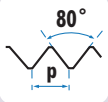

HSS

DIN
40430

HSS

DIN
223

Ref. MO

Ref. C5

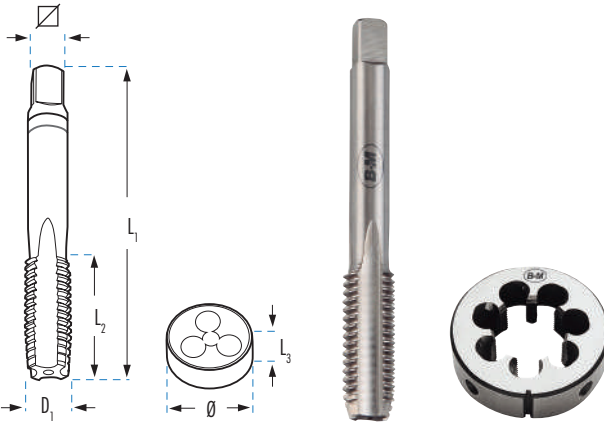

Icona	U.ità	D1 mm	Ø	L1 x L2 x mm	MO		C5	
					€	Ø x L3 mm	€	
Pg 7	20h.	1	12,5	11,50	70x20x7,0	40,54	38x10	75,01
Pg 9	18h.	1	15,2	14,00	70x20x9,0	51,54	38x10	91,35
Pg 11	18h.	1	18,6	17,25	80x22x11,0	71,55	45x14	91,36
Pg 13,5	18h.	1	20,4	19,00	80x22x12,0	78,48	45x14	91,36
Pg 16	18h.	1	22,5	21,25	80x22x14,5	94,25	55x16	105,45
Pg 21	16h.	1	28,3	27,00	90x22x18,0	138,60	65x18	159,01
Pg 29	16h.	1	37,0	35,50	100x25x22,0	275,20	65x18	159,01
Pg 36	16h.	1	47,0	45,50	140x32x29,0	404,41	90x22	452,96
Pg 42	16h.	1	54,0	52,50	140x36x32,0	480,25	105x22	452,96
Pg 48	16h.	1	59,3	58,00	160x36x35,0	605,70	105x22	600,65

NPSF

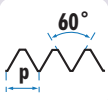
Filettatura AMERICANA
Filettatura cilindrica a tenuta stagna

HSS

HSS

DIN
223

Ref. MO

Ref. C5

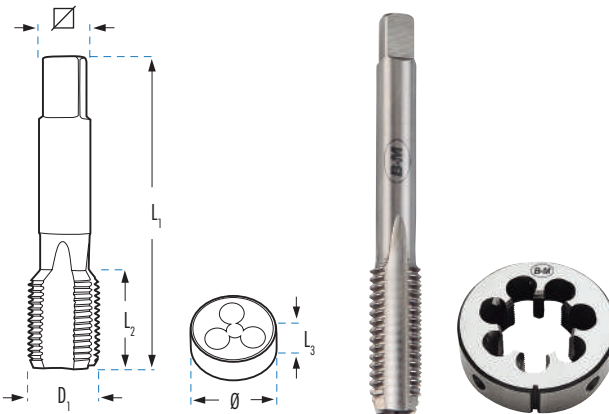

Icona	U.ità	D1 mm	Ø	L1 x L2 x mm	MO		C5	
					€	Ø x L3 mm	€	
NPSF 1/8-27 h.	1	10,05	8,75	63x18x5,5	138,94	38x10	242,07	
NPSF 1/4-18 h.	1	13,35	11,30	70x20x9,0	200,77	38x10	242,07	
NPSF 3/8-18 h.	1	16,78	14,70	70x20x9,0	277,71	45x14	307,93	
NPSF 1/2-14 h.	1	20,87	18,20	80x22x12,0	363,06	45x14	307,93	
NPSF 3/4-14 h.	1	26,23	23,50	90x22x16,0	552,42	55x16	665,61	

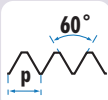
NPS
(M)Filettatura AMERICANA
Filettatura cilindrica non a tenuta stagna (Briggs)

HSS

HSS

DIN
223

Ref. MO

Ref. C5

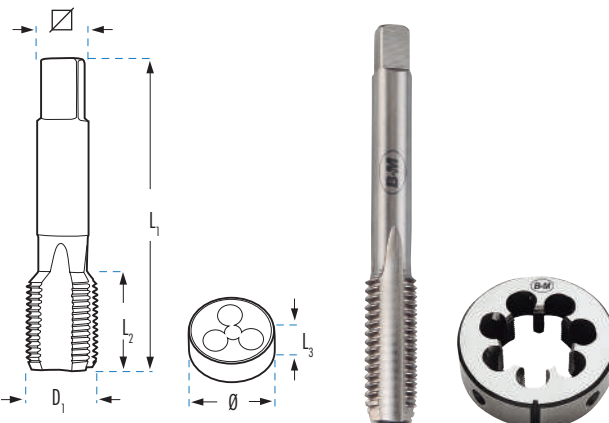

Icona	U.ità	D1 mm	Ø	L1 x L2 x mm	MO		C5	
					€	Ø x L3 mm	€	
NPS 1/8-27 h.	1	10,20	8,9	63x18x5,5	115,13	38x10	201,65	
NPS 1/4-18 h.	1	13,60	11,7	70x20x9,0	91,63	38x10	201,65	
NPS 3/8-18 h.	1	17,00	15,0	70x20x9,0	126,72	45x14	256,59	
NPS 1/2-14 h.	1	21,20	18,6	80x22x12,0	165,62	45x14	256,59	
NPS 3/4-14 h.	1	26,55	24,0	90x22x16,0	240,55	55x16	508,31	
NPS 1"-11,5 h.	1	33,20	30,0	100x25x20,0	336,34	65x18	472,17	

SERIE DI MASCHI E FILIERE PER FILETTARE A MANO HSS

BSPT

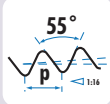

Ref. MO

HSS

DIN 5157

Ref. C5

HSS

DIN 223

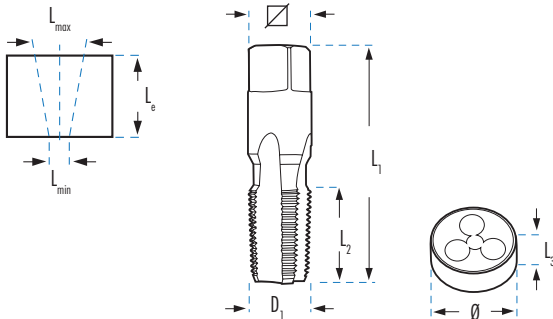

Icona	U.tà	D1 mm	Ø	L min x L max mm	L _e mm	L1 x L2 x mm	MO		C5	
							€	Ø x L3 mm	€	
	1	9,73	8,30	8,00 x 8,50	10,1	65 x 19 x 5,5	40,64	30 x 11	54,03	
	1	13,16	11,00	10,70 x 11,35	15,0	70 x 25 x 9,0	49,55	38 x 14	56,36	
	1	16,66	14,50	14,15 x 14,25	15,4	70 x 25 x 9,0	68,83	45 x 16	98,51	
	1	20,95	18,10	17,60 x 18,50	20,5	80 x 31 x 12,0	96,38	55 x 22	98,51	
	1	22,91	20,00	19,50 x 20,40	22,4	80 x 36 x 14,5	179,70	55 x 19	187,14	
	1	26,44	23,50	23,00 x 24,00	21,8	85 x 33 x 16,0	160,77	55 x 22	212,41	
	1	30,20	27,25	26,65 x 28,75	24,0	100 x 36 x 18,0	344,40	65 x 22	265,75	
	1	33,25	29,60	29,00 x 30,20	26,0	110 x 38 x 20,0	229,69	65 x 25	234,61	

BA

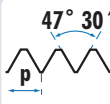

Ref. MO

HSS

DIN 352

Ref. C5

HSS

DIN 223

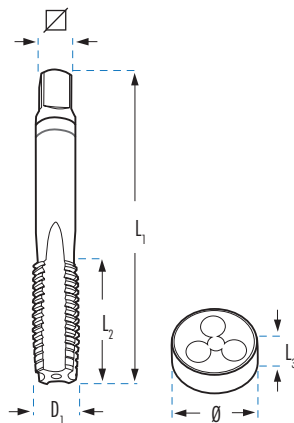

Icona	U.tà	D1 mm	Ø	L1 x L2 x mm	MO		C5	
					€	Ø x L3 mm	€	
	1,00	3	6,0	5,1	50 x 18 x 4,9	201,28	20 x 5	97,49
	0,90	3	5,3	4,5	50 x 18 x 4,9	201,28	20 x 5	97,49
	0,81	3	4,7	4,0	50 x 17 x 4,9	201,28	20 x 5	97,49
	0,73	3	4,1	3,4	45 x 14 x 3,4	216,32	20 x 5	97,49
	0,66	3	3,6	3,0	45 x 14 x 3,0	216,32	20 x 5	97,49
	0,59	3	3,2	2,6	45 x 14 x 3,0	258,46	20 x 5	97,49
	0,53	3	2,8	2,3	40 x 12 x 2,7	258,46	20 x 5	97,49
	0,48	3	2,5	2,0	40 x 10 x 2,1	284,17	20 x 5	97,49
	0,43	3	2,2	1,8	36 x 10 x 2,1	284,17	20 x 5	97,49

SERIE DI MASCHI E FILIERE PER FILETTARE A MANO HSS

Maschi e Filiere

Verde

UNx8

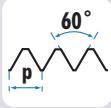

Filettatura AMERICANA

Ref. MO



HSS

DIN
2181TOL
2B

Ref. C5

HSS

DIN
223TOL
2a

 	U.ità	D1 mm		L1 x L2 x mm	MO		C5	
					€	Ø x L3 mm	€	
UN 1"1/8-8h.	2	28,57	25,40	138x65x17,0	386,94	65x25	408,27	
UN 1"1/4-8h.	2	31,75	28,50	146x65x19,5	501,80	65x25	408,27	
UN 1"3/8-8h.	2	34,92	31,75	154x76x21,0	624,11	65x25	391,28	
UN 1"1/2-8h.	2	38,10	35,00	162x76x23,5	714,23	75x30	442,96	
UN 1"5/8-8h.	2	41,27	38,10	170x80x25,0	887,99	75x30	442,96	
UN 1"3/4-8h.	2	44,45	41,25	178x81x27,0	1.106,68	90x36	516,78	
UN 1"7/8-8h.	2	47,62	44,45	186x90x29,0	1.380,64	90x36	611,44	
UN 2"-8h.	2	50,80	47,63	194x90x31,5	1.413,55	90x36	631,07	
UN 2"1/4-8h.	2	57,15	54,00	208x90x36,0				
UN 2"1/2-8h.	2	63,50	60,35	220x100x36,0				
UN 2"3/4-8h.	2	69,85	66,70	234x104x39,0				
UN 3"-8h.	2	76,20	73,05	248x115x49,0				

UNEF

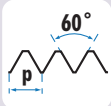

Filettatura AMERICANA

Ref. MO

HSS

DIN
2181TOL
2B

Ref. C5

HSS

DIN
223TOL
2a

 	U.ità	D1 mm		L1 x L2 x mm	MO		C5	
					€	Ø x L3 mm	€	
UNEF 1/4-32h.	2	6,35	5,55	65x28x4,9	37,82	20x7	76,37	
UNEF 5/16-32h.	2	7,94	7,15	70x30x6,0	42,25	25x9	95,42	
UNEF 3/8-32h.	2	9,52	8,70	75x33x7,0	47,49	30x11	108,10	
UNEF 7/16-28h.	2	11,11	10,20	81x38x6,0	59,39	30x11	150,16	
UNEF 1/2-28h.	2	12,70	11,80	86x44x7,0	70,77	38x10	158,81	
UNEF 9/16-24h.	2	14,29	13,20	92x44x8,0	67,88	38x10	150,16	
UNEF 5/8-24h.	2	15,87	14,80	93x47x9,0	76,47	45x14	248,79	
UNEF 3/4-20h.	2	19,05	17,80	108x52x11,0	102,13	45x14	248,79	
UNEF 7/8-20h.	2	22,22	20,95	120x58x13,0	138,56	55x16	297,08	
UNEF 1"-20h.	2	25,40	24,20	130x65x15,0	162,03	55x16	292,03	

SERIE DI MASCHI E FILIERE PER FILETTARE A MANO APPLICAZIONI SPECIALI



Ref. MOMD

HSSCo
5%



DIN
352

OX

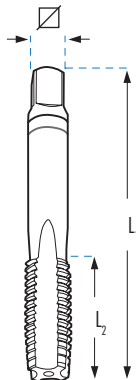

SPECIALE MATERIALI DURI
(≤ 1100 N/mm²=40HRc)



				MOMD
	U.ità		L ₁ x L ₂ x mm	€
M 3 x 0,50	3	2,50	40 x 11 x 2,7	40,83
M 4 x 0,70	3	3,30	45 x 13 x 3,4	40,83
M 5 x 0,80	3	4,20	50 x 17 x 4,9	42,17
M 6 x 1,00	3	5,00	50 x 19 x 4,9	43,41
M 8 x 1,25	3	6,80	56 x 20 x 4,9	49,34
M 10 x 1,50	3	8,50	70 x 22 x 5,5	63,35
M 12 x 1,75	3	10,20	75 x 24 x 7,0	90,68
M 14 x 2,00	3	12,00	80 x 26 x 9,0	107,35
M 16 x 2,00	3	14,00	80 x 27 x 9,0	142,63
M 18 x 2,50	3	15,50	95 x 30 x 11,0	219,34
M 20 x 2,50	3	17,50	95 x 32 x 12,0	243,53

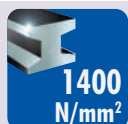

Ref. MOC



HSS
PM

TiAlSiN

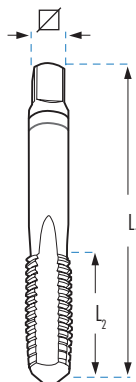

SPECIALE MATERIALI MOLTO DURI
(≤ 1400 N/mm²=44HRc)



				MOC
	U.ità		L ₁ x L ₂ x mm	€
M 3 x 0,50	3	2,50	40 x 11 x 2,7	88,86
M 4 x 0,70	3	3,30	45 x 13 x 3,4	95,87
M 5 x 0,80	3	4,20	50 x 17 x 4,9	97,07
M 6 x 1,00	3	5,00	50 x 19 x 4,9	97,07
M 8 x 1,25	3	6,80	56 x 20 x 4,9	109,41
M 10 x 1,50	3	8,50	70 x 22 x 5,5	135,24
M 12 x 1,75	3	10,20	75 x 24 x 7,0	164,41
M 14 x 2,00	3	12,00	80 x 26 x 9,0	197,24
M 16 x 2,00	3	14,00	80 x 27 x 9,0	241,70
M 18 x 2,50	3	15,50	95 x 30 x 11,0	335,12
M 20 x 2,50	3	17,50	95 x 32 x 12,0	368,82

AI

Ref. MOAL



HSS

BRILLANTE

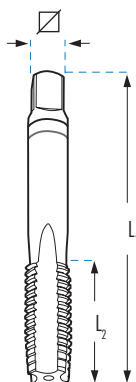

SPECIALE ALLUMINIO



				MOAL
	U.ità		L ₁ x L ₂ x mm	€
M 3 x 0,50	3	2,50	40 x 11 x 2,7	31,80
M 4 x 0,70	3	3,30	45 x 13 x 3,4	30,87
M 5 x 0,80	3	4,20	50 x 17 x 4,9	32,71
M 6 x 1,00	3	5,00	50 x 19 x 4,9	32,71
M 8 x 1,25	3	6,80	56 x 20 x 4,9	40,15
M 10 x 1,50	3	8,50	70 x 22 x 5,5	49,03
M 12 x 1,75	3	10,20	75 x 24 x 7,0	69,02
M 14 x 2,00	3	12,00	80 x 26 x 9,0	79,32
M 16 x 2,00	3	14,00	80 x 27 x 9,0	112,59
M 18 x 2,50	3	15,50	95 x 30 x 11,0	149,21
M 20 x 2,50	3	17,50	95 x 32 x 12,0	168,20

SERIE DI MASCHI E FILIERE PER FILETTARE A MANO INOX

M

INOX

Ref. MOT
Ref. MOXDIN
352TOL
6H

TiN

Ref. C5T
Ref. C5XDIN
223TOL
6g

OX

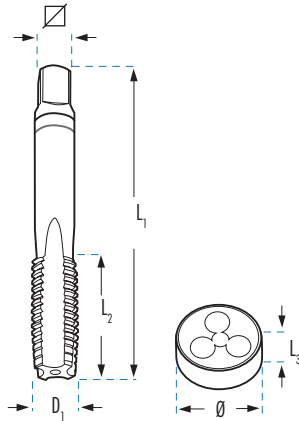

	U.tà	L1 x L2 x ∇ mm	MOT	C5T	MOX	C5X	Ø x L3 mm
			HSS TiN €	HSS TiN €	HSSCo OX €	HSSCo OX €	
M 3 x 0,50	3	40 x 11 x 2,70	29,78	26,91	34,28	29,38	20 x 5
M 4 x 0,70	3	45 x 13 x 3,40	26,07	62,56	34,28	29,38	20 x 5
M 5 x 0,80	3	50 x 16 x 4,90	28,61	28,16	34,78	28,04	20 x 7
M 6 x 1,00	3	50 x 19 x 4,90	28,61	28,16	34,70	28,01	20 x 7
M 8 x 1,00	2	50 x 19 x 4,90	30,62				
M 8 x 1,25	3	56 x 22 x 4,90	37,82	28,87	39,84	36,50	25 x 9
M 10 x 1,00	2	63 x 18 x 5,50	35,33				
M 10 x 1,50	3	70 x 24 x 5,50	44,28	36,20	53,28	48,83	30 x 11
M 12 x 1,50	2	70 x 20 x 7,00	44,97				
M 12 x 1,75	3	75 x 29 x 7,00	47,67	52,28	69,55	72,26	38 x 14
M 14 x 1,50	2	70 x 20 x 9,00	52,29				
M 14 x 2,00	3	80 x 30 x 9,00	70,18	57,89	87,71	72,26	38 x 14
M 16 x 2,00	3	80 x 32 x 9,00	76,59	73,63	107,01	104,55	45 x 18
M 18 x 2,50	3	95 x 40 x 11,00	98,92		140,15		
M 20 x 2,50	3	95 x 40 x 12,00	105,95		157,77		
M 22 x 2,50	3	100 x 40 x 14,50	134,00				
M 24 x 3,00	3	110 x 50 x 14,50	174,29				

M

FILIERE ESAGONALI HSS PER FILETTARE A MANO

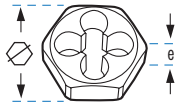

M **HSS** **DIN 382**

		C5HM	
			€
M 3 x 0,35	18 x 5	41,26	
M 3 x 0,50	19 x 5	23,24	
M 3,5 x 0,60	18 x 5	41,26	
M 4 x 0,50	18 x 5	41,26	
M 4 x 0,70	19 x 5	21,78	
M 5 x 0,50	18 x 5	41,26	
M 5 x 0,75	18 x 5	41,26	
M 5 x 0,80	19 x 7	21,78	
M 6 x 0,75	18 x 7	45,25	
M 6 x 1,00	19 x 7	23,24	
M 7 x 0,75	21 x 9	43,85	
M 7 x 1,00	21 x 9	24,63	
M 8 x 0,75	21 x 9	47,85	
M 8 x 1,00	21 x 9	47,85	
M 8 x 1,25	22 x 9	24,63	
M 9 x 0,75	21 x 9	49,63	
M 9 x 1,00	21 x 9	49,63	
M 9 x 1,25	22 x 9	44,68	
M 10 x 1,00	27 x 11	47,84	
M 10 x 1,25	27 x 11	47,84	
M 10 x 1,50	27 x 11	28,34	
M 11 x 1,00	27 x 11	74,43	
M 11 x 1,50	27 x 11	74,43	
M 12 x 1,25	36 x 10	64,01	
M 12 x 1,50	36 x 10	64,01	
M 12 x 1,75	36 x 10	41,29	
M 14 x 1,25	36 x 14	71,54	
M 14 x 1,50	36 x 10	71,54	
M 14 x 2,00	36 x 10	37,16	
M 15 x 1,00	36 x 14	98,10	
M 15 x 1,50	41 x 14	98,10	
M 16 x 1,00	41 x 14	86,60	
M 16 x 1,50	41 x 14	86,60	

		C5HM	
			€
M 16 x 2,00	41 x 18	56,08	
M 18 x 1,00	41 x 14	98,10	
M 18 x 1,50	41 x 14	91,12	
M 18 x 2,50	41 x 18	50,48	
M 20 x 1,00	41 x 14	98,10	
M 20 x 1,50	41 x 14	91,12	
M 20 x 2,00	41 x 18	98,10	
M 20 x 2,50	41 x 18	56,08	
M 22 x 1,00	50 x 16	143,32	
M 22 x 1,50	50 x 16	129,04	
M 22 x 2,00	50 x 16	143,32	
M 22 x 2,50	50 x 16	93,73	
M 24 x 1,00	50 x 16	231,28	
M 24 x 1,50	50 x 16	129,03	
M 24 x 2,00	50 x 16	129,03	
M 24 x 3,00	50 x 22	113,25	
M 27 x 1,50	60 x 18	193,78	
M 27 x 2,00	60 x 18	193,78	
M 27 x 3,00	60 x 25	166,91	
M 30 x 1,00	60 x 18	193,78	
M 30 x 1,50	60 x 18	193,78	
M 30 x 2,00	60 x 18	191,00	
M 30 x 3,00	60 x 18	193,78	
M 30 x 3,50	60 x 25	166,91	
M 33 x 1,50	60 x 18	216,98	
M 33 x 2,00	60 x 18	216,98	
M 33 x 3,50	60 x 25	186,21	
M 35 x 1,50	60 x 18	206,83	
M 36 x 1,50	60 x 18	206,83	
M 36 x 2,00	60 x 18	206,83	
M 36 x 3,00	60 x 18	206,83	
M 36 x 4,00	60 x 25	172,36	

BSP (GAS) **HSS** **DIN 382**

		C5HG	
			€
G 1/8 x 28h.	27 x 11	84,00	
G 1/4 x 19h.	36 x 10	84,00	
G 3/8 x 19h.	41 x 14	105,03	
G 1/2 x 14h.	41 x 14	105,03	
G 5/8 x 14h.	50 x 16	247,29	
G 3/4 x 14h.	50 x 16	247,29	
G 7/8 x 14h.	60 x 18	249,51	
G 1" x 11h.	60 x 18	249,51	
G1.1/4 x 11h.	70 x 20	332,67	
G1.1/2 x 11h.	85 x 22	561,24	
G 2" x 11h.	100 x 22	844,52	

UNC **HSS** **DIN 382**

		C5HNC	
			€
UNC 1/4-20h	18 x 7	34,78	
UNC 5/16-18h	21 x 9	43,29	
UNC 3/8-16h	27 x 11	52,24	
UNC 7/16-14h	27 x 11	77,11	
UNC 1/2-13h	36 x 14	77,38	
UNC 9/16-12h	36 x 14	92,46	
UNC 5/8-11h	41 x 18	71,65	
UNC 3/4-10h	41 x 18	113,98	
UNC 7/8-9h	50 x 22	161,75	
UNC 1"-8h	50 x 22	161,75	
UNC 1.1/8-7h	60 x 25	213,85	
UNC 1.1/4-7h	60 x 25	213,85	

UNF **HSS** **DIN 382**

		C5HNF	
			€
UNF 1/4-28h.	18 x 7	36,87	
UNF 5/16-24h.	21 x 9	46,09	
UNF 3/8-24h.	27 x 11	55,44	
UNF 7/16-20h.	27 x 11	81,71	
UNF 1/2-20h.	36 x 10	82,97	
UNF 9/16-18h.	36 x 10	92,46	
UNF 5/8-18h.	41 x 14	115,37	
UNF 3/4-16h.	41 x 14	120,82	
UNF 7/8-14h.	50 x 16	152,81	
UNF 1"-12h.	50 x 16	160,21	
UNS 1"-14h.	50 x 16	160,21	
UNF 1.1/8-12h.	60 x 18	213,85	
UNF 1.1/4-12h.	60 x 18	213,85	

BSW **HSS** **DIN 382**

		C5HW	
			€
BSW 1/8 x 40h.	19 x 5	47,71	
BSW 3/16 x 24h.	19 x 7	47,71	
BSW 1/4 x 20h.	19 x 7	47,71	
BSW 5/16 x 18h.	22 x 9	50,10	
BSW 3/8 x 16h.	27 x 11	59,64	
BSW 7/16 x 14h.	27 x 11	59,64	
BSW 1/2 x 12h.	36 x 14	71,59	

		C5HW	
			€
BSW 9/16 x 12h.	36 x 14	71,59	
BSW 5/8 x 11h.	41 x 18	105,80	
BSW 3/4 x 10h.	41 x 18	105,80	
BSW 7/8 x 9h.	50 x 22	155,05	
BSW 1" x 8h.	50 x 22	155,05	
BSW 1.1/8 x 7h.	60 x 25	267,26	

SERIE DI MASCHI E FILIERE PER FILETTARE A MANO, A SINISTRA

M
MF

DIN 13

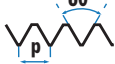

Ref. MOI

HSS

(M)

DIN
352

(MF)

DIN
2181TOL
6H

Ref. CSI

HSS

DIN
223TOL
6g

Per materiali fino a 38 HRc.

UNC

UNF

BSP
(GAS)

BSW



A SINISTRA

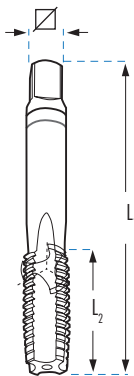

	U.ità	D1 mm	L1 x L2 x mm	MOI		CSI	
				€	Ø x L3 mm	€	€
M 2x0,40	3	1,60	36x9,0x2,1	59,43	16x5	61,05	
M 3x0,50	3	2,50	40x11,0x2,7	30,32	25x9	34,76	
M 4x0,70	3	3,30	45x13,0x3,4	30,30	25x9	34,76	
M 5x0,80	3	4,20	50x16,0x4,9	33,83	25x9	35,85	
M 6x1,00	3	5,00	50x19x4,9	34,20	25x9	38,60	
M 7x1,00	3	6,00	50x19x4,9	45,07	25x9	51,03	
M 8x1,00	2	7,00	56x18x4,9	42,52	25x9	55,61	
M 8x1,25	3	6,80	56x22x4,9	37,39	25x9	39,42	
M 9x1,25	3	7,80	63x22x5,5	50,74	25x9	58,23	
M 10x1,50	3	8,50	70x24x5,5	48,14	38x10	45,13	
M 12x1,50	2	10,50	70x20x7,0	75,35	38x10	76,36	
M 12x1,75	3	10,20	75x29x7,0	60,67	38x14	65,29	
M 14x1,25	2	12,80	70x20x9,0	94,95	38x10	88,26	
M 14x2,00	3	12,00	80x30x9,0	78,09	38x14	71,21	
M 16x1,50	2	14,50	70x20x9,0	100,01	45x14	104,66	
M 16x2,00	3	14,00	80x32x9,0	93,67	45x18	83,54	
M 18x2,00	2	16,00	80x22x11,0	151,16	45x14	123,67	
M 18x2,50	3	15,50	95x40x11,0	124,44	45x18	94,88	
M 20x2,00	2	18,00	80x22x12,0	194,30	45x14	120,41	
M 20x2,50	3	17,50	95x40x12,0	137,36	45x18	92,27	
M 22x2,00	2	20,00	80x22x14,5	188,51	55x16	211,72	
M 22x2,50	3	19,50	100x40x14,5	192,10	55x22	169,24	
M 24x2,00	2	22,00	90x22x14,5	256,88	55x16	215,74	
M 24x3,00	3	21,00	110x50x14,5	222,58	55x22	169,24	
M 27x2,00	2	25,00	90x22x16,0	460,14	65x18	318,85	
M 27x3,00	3	24,00	110x50x16,0	289,74	65x25	256,71	
M 30x3,00	2	27,00	125x56x18,0	487,77	65x25	226,78	
M 30x3,50	3	26,50	125x50x18,0	367,15	65x25	236,92	
M 33x2,00	2	31,00	100x25x20,0	741,81	65x18	266,81	
M 33x3,50	3	29,50	125x50x20,0	631,55	65x25	236,86	
M 36x3,00	2	33,00	125x33x22,0	855,77	65x25	282,74	
M 36x4,00	3	32,00	150x53x22,0	783,46	65x25	236,92	
M 39x3,00	2	36,00	125x33x24,0	962,99	75x30	442,95	
M 39x4,00	3	35,00	150x53x24,0	886,62	75x30	367,16	

	U.ità	D1 mm	L1 x L2 x mm	MOI		CSI	
				€	Ø x L3 mm	€	€
UNC 1/4-20h.	3	6,35	5,10	50x19x4,9	65,20	20x7	65,03
UNC 5/16-18h.	3	7,94	6,60	56x22x4,9	71,77	25x9	72,02
UNC 3/8-16h.	3	9,52	8,00	70x24x5,5	80,38	30x11	75,99
UNC 1/2-13h.	3	12,70	10,75	75x29x7,0	133,84	38x14	97,54
UNC 5/8-11h.	3	15,87	13,50	80x32x9,0	178,99	45x18	107,33
UNC 3/4-10h.	3	19,05	16,50	95x40x11,0	237,50	45x18	125,95
UNC 1"-8h.	3	25,40	22,25	110x50x14,5	352,53	55x22	186,84

	U.ità	D1 mm	L1 x L2 x mm	MOI		CSI	
				€	Ø x L3 mm	€	€
UNF 1/4-28h.	2	6,35	5,50	50x14x4,9	44,60	25x9	65,03
UNF 5/16-24h.	2	7,94	6,90	56x22x4,9	44,23	25x9	72,06
UNF 3/8-24h.	2	9,52	8,50	63x20x5,5	64,05	38x10	74,80
UNF 1/2-20h.	2	12,70	11,50	70x22x7,0	79,25	38x10	97,54
UNF 5/8-18h.	2	15,87	14,50	70x22x9,0	111,14	45x14	107,33
UNF 3/4-16h.	2	19,05	17,50	80x22x11,0	144,32	45x14	125,95
UNS 1"-14h.	2	25,40	23,60	90x22x14,5	321,15	55x16	243,76

	U.ità	D1 mm	L1 x L2 x mm	MOI		CSI	
				€	Ø x L3 mm	€	€
G 1/8-28h.	2	9,73	8,80	63 x 20 x 5,5	66,97	38x10	90,56
G 1/4-19h.	2	13,16	11,80	70 x 22 x 9,0	71,52	38x10	84,85
G 3/8-19h.	2	16,66	15,25	70 x 22 x 9,0	104,77	45x14	114,91
G 1/2-14h.	2	20,95	19,00	80 x 22 x 12,0	164,51	45x14	114,91
G 5/8-14h.	2	22,91	21,00	80 x 22 x 14,5	195,37	55x16	182,25
G 3/4-14h.	2	26,44	24,50	90 x 22 x 16,0	240,28	55x16	182,23
G 1"-11h.	2	33,25	30,75	100 x 25 x 20,0	360,15	65x18	234,35
G 1.1/4-11h.	2	41,91	39,50	125 x 40 x 24,0	579,33	75x20	362,05

	U.ità	D1 mm	L1 x L2 x mm	MOI		CSI	
				€	Ø x L3 mm	€	€
W 1/8-40h.	3	3,17	2,55	40x14x2,7	65,05	25x9	65,03
W 1/4-20h.	3	6,35	5,10	50x20x4,9	61,55	25x9	65,03
W 5/16-18h.	3	7,94	6,50	56x20x4,9	71,61	25x9	72,06
W 3/8-16h.	3	9,52	7,90	63x22x5,5	88,50	38x10	77,83
W 5/8-11h.	3	15,87	13,40	80x27x9,0	170,63	45x18	117,85
W 3/4-10h.	3	19,05	16,50	95x32x11,0	227,09	45x18	125,99
W 7/8-9h.	3	22,22	19,25	100x32x14,5	280,02	55x22	186,82
W 1"-8h.	3	25,40	21,75	110x36x14,5	459,32	55x22	186,82

MASCHIO N°3 PER FILETTARE A MANO, FILETTO METRICO, A SINISTRA E A DESTRA

**M
MF**

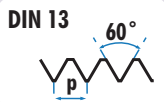

HSS

**DIN
352**

**TOL
6H**

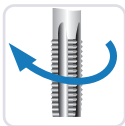

A SINISTRA

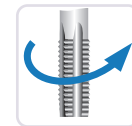

A DESTRA

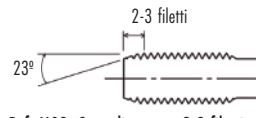
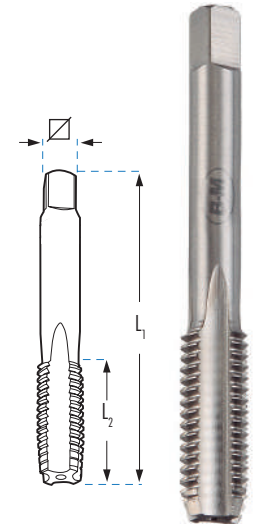

Ref. M03: Cono di entrata 2-3 filetti

**D
CODOLO
SOTTILE**

**DIN
352**

			M03I	
		\emptyset	L1 x L2 x D2 x ∇ mm	€
M 3x0,50	2,50	D	40 x 11 x 3,50 x 2,70	10,11
M 4x0,70	3,30	D	45 x 13 x 4,50 x 3,40	10,10
M 5x0,80	4,20	D	50 x 16 x 6,00 x 4,90	11,28
M 6x1,00	5,00	D	50 x 19 x 6,00 x 4,90	11,40
M 7x1,00	6,00	D	50 x 19 x 6,00 x 4,90	15,02
M 8x1,25	6,75	D	56 x 22 x 6,00 x 4,90	12,46
M 10x1,50	8,50	D	70 x 24 x 7,00 x 5,50	16,05
M 12x1,75	10,20	D	75 x 29 x 9,00 x 7,00	20,22
M 14x2,00	12,00	D	80 x 30 x 11,00 x 9,00	26,03
M 16x2,00	14,00	D	80 x 32 x 12,00 x 9,00	31,22
M 18x2,50	15,50	D	95 x 40 x 14,00 x 11,00	41,48
M 20x2,50	17,50	D	95 x 40 x 16,00 x 12,00	45,79

Consultare altre misure disponibili su richiesta.

			M03	
		\emptyset	L1 x L2 x D2 x ∇ mm	€
M 3x0,50	2,50	D	40 x 11 x 3,50 x 2,70	5,05
M 4x0,70	3,30	D	45 x 13 x 4,50 x 3,40	5,05
M 5x0,80	4,20	D	50 x 16 x 6,00 x 4,90	5,64
M 6x1,00	5,00	D	50 x 19 x 6,00 x 4,90	5,70
M 7x1,00	6,00	D	50 x 19 x 6,00 x 4,90	7,51
M 8x1,00	7,00	D	56 x 18 x 6,00 x 4,90	10,63
M 8x1,25	6,75	D	56 x 22 x 6,00 x 4,90	6,23
M 9x1,25	7,75	D	63 x 18 x 7,00 x 5,50	8,46
M 10x1,00	9,00	D	63 x 18 x 7,00 x 5,50	12,50
M 10x1,25	8,80	D	70 x 24 x 7,00 x 5,50	11,64
M 10x1,50	8,50	D	70 x 24 x 7,00 x 5,50	8,02
M 12x1,00	11,00	D	70 x 20 x 9,00 x 7,00	20,49
M 12x1,25	10,75	D	70 x 20 x 9,00 x 7,00	20,42
M 12x1,50	10,50	D	70 x 20 x 9,00 x 7,00	18,84
M 12x1,75	10,20	D	75 x 29 x 9,00 x 7,00	10,11
M 14x1,00	13,00	D	70 x 20 x 11,00 x 9,00	31,82
M 14x1,25	12,80	D	70 x 20 x 11,00 x 9,00	23,74
M 14x1,50	12,50	D	70 x 20 x 11,00 x 9,00	20,34
M 14x2,00	12,00	D	80 x 30 x 11,00 x 9,00	13,02
M 16x1,00	15,00	D	70 x 20 x 12,00 x 9,00	34,70
M 16x1,25	14,75	D	70 x 20 x 12,00 x 9,00	34,91
M 16x1,50	14,50	D	70 x 20 x 12,00 x 9,00	25,00
M 16x2,00	14,00	D	80 x 32 x 12,00 x 9,00	15,61
M 18x1,50	16,50	D	80 x 22 x 14,00 x 11,00	25,51
M 18x2,50	15,50	D	95 x 40 x 14,00 x 11,00	20,74
M 20x1,50	18,50	D	80 x 22 x 16,00 x 12,00	27,63
M 20x2,50	17,50	D	95 x 40 x 16,00 x 12,00	22,89
M 22x2,50	19,50	D	100 x 40 x 18,00 x 14,50	32,02
M 24x3,00	21,00	D	110 x 50 x 18,00 x 14,50	37,10
M 27x3,00	24,00	D	110 x 50 x 20,00 x 16,00	48,29
M 30x3,50	26,50	D	125 x 50 x 22,00 x 18,00	61,19

CALIBRI PER IL CONTROLLO DEI PASSI DELLA FILETTATURA



GAM	TIPI DI FILETTATURA	INTERVALLO DI PASSI		GAM
		Metrici	Inglese	€
GAM	Passi filettatura metrica	0,25 - 2,5		13,33
GAMW	Passi filettatura metrica / filettatura inglese	0,25 - 6,0	62h - 4h	17,65

INSIEME DI GUIDE PER FILIERE M3-M12

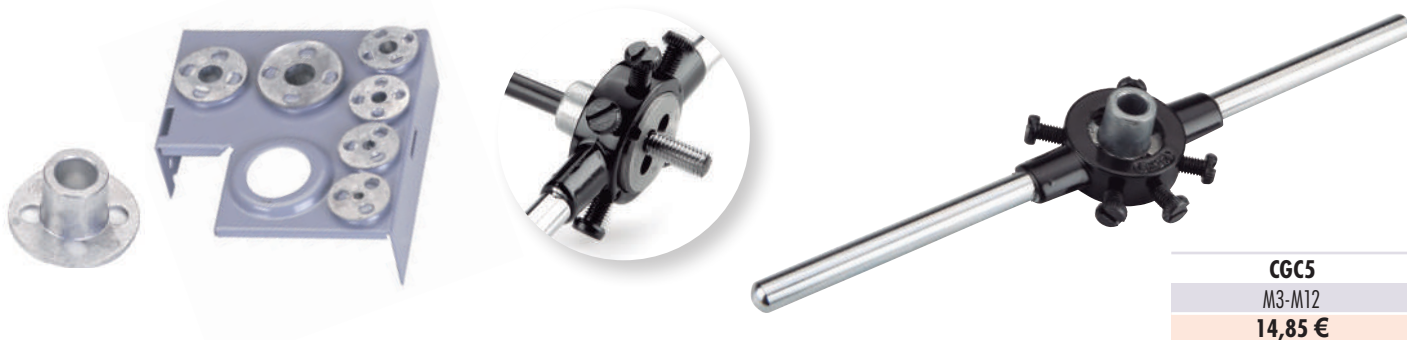

CGC5
M3-M12
14,85 €

PROLUNGA PER MASCHI

DIN
377

DIN 10

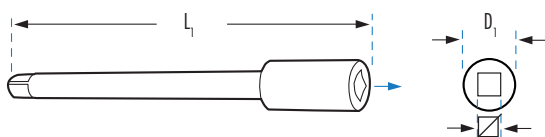

Stessa misura del attacco quadro in entrambe le zone maschio e femmina.

	∅ x L1 mm	D1 mm	AL €
AL21	2,1 x 60	6,0	8,76
AL24	2,4 x 70	6,0	8,76
AL27	2,7 x 80	7,0	8,76
AL30	3,0 x 90	7,0	8,76
AL34	3,4 x 95	8,0	9,49
AL38	3,8 x 95	9,0	9,91
AL43	4,3 x 105	10,0	11,04
AL49	4,9 x 110	11,0	10,65
AL55	5,5 x 115	12,0	10,82
AL62	6,2 x 120	14,0	13,54
AL70	7,0 x 125	15,0	14,69
AL80	8,0 x 125	17,0	18,33
AL90	9,0 x 135	19,0	18,84

	∅ x L1 mm	D1 mm	AL €
AL100	10,0 x 140	21,0	18,41
AL110	11,0 x 150	23,0	22,42
AL120	12,0 x 160	25,0	28,41
AL130	13,0 x 165	27,0	44,44
AL145	14,5 x 175	29,0	43,32
AL160	16,0 x 185	30,0	47,67
AL180	18,0 x 195	33,0	54,34
AL200	20,0 x 220	36,0	72,46
AL220	22,0 x 220	40,0	105,89
AL240	24,0 x 235	42,0	157,78
AL260	26,0 x 245	45,0	171,43
AL290	29,0 x 260	55,0	197,57
AL320	32,0 x 280	55,0	247,92

Massima
Resistenza
150 kg/mm²

GIRAMASCHI IN ACCIAIO FORGIATO

Ref. GAPRO

- Corpo in Acciaio Forgiato.
- Sopporta sforzi fino a 150 kg/mm.
- Massima resistenza e durabilità.

- Maggiore precisione e fermezza nell'attacco.
- La filettatura di precisione forma un insieme solido e robusto.
- Impugnatura antiscivolo, maggiore aderenza.

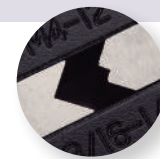

GAPRO

N° NORMA	N° 0	N° 1	N° 1.1/2	N° 2	N° 3	N° 4	N° 5
	M1-M8 2,00-5,00	M1-M10 2,00-6,30	M1-M12 2,50-7,00	M1-M12 2,50-8,00	M5-M20 4,00-13,00	M5-M27 4,00-16,00	M9-M32 5,50-20,00
€	18,25	18,54	24,63	31,12	44,05	70,42	149,05

Ref. GA

- Corpo in Lega di Zinco.
- Alta resistenza e durabilità.
- Alta precisione e fermezza nell'attacco.



GA

N° NORMA	N° 0	N° 1	N° 1.1/2	N° 2	N° 3	N° 4	N° 5	N° 7	N° 8
	M1-M8 1,50-5,00	M1-M10 2,00-7,00	M1-M12 2,00-8,00	M4-M12 2,50-10,00	M5-M20 3,50-14,00	M9-M27 4,00-15,00	M13-M32 5,50-19,00	M22-M52 14,00-34,00	M33-M64 16,00-40,00
€	10,18	12,32	16,55	20,92	29,61	47,35	100,22	206,76	425,75

GIRAFILIERE IN ACCIAIO

Ref. VA

**DIN
225**



5

IMPORTANTE: Al momento dell'ordine, indichi lo spessore del girafiliera in base agli spessori delle filiere indicati nella tariffa.

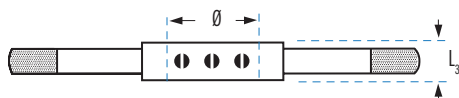

VA

Ø x L3 mm	16x5	20x5	20x7	25x9	30x11	38x10	38x14	45x14	45x18	55x16	55x22	65x18	65x25
€	10,65	11,78	11,78	13,45	16,29	21,30	21,27	26,14	26,35	33,79	35,40	48,43	48,43
Ø x L3 mm	75x20	75x30	90x22	90x36	105x22	105x36	120x22	120x36	130x25	130x36			
€	97,76	102,32	123,83	133,40	186,01	186,01	483,77	483,77	502,93	502,93			

Ref. VA

POLLICI



3



VA

Ø mm	20,60	25,40	38,10	50,80	63,50	76,20	88,90
POLLICI	13/16"	1"	1.1/2"	2"	2.1/2"	3"	3.1/2"
€	13,45	15,95	23,87	35,41	55,87	103,32	130,88

NOTA: I girafiliera con Ø esterno in pollici sono in disuso.

GIRAMASCHI A CRICCHETTO

Ref. TC

TIPO
T

SERIE CORTA



	CAPACITÀ mm min.-max.	Per codoli di maschi		L1 mm	PESO g	QUALITÀ	TC
		DIN	ISO				€
TC3B	2,6 - 5,5	M3 - 8	M3 - 6	85	180	1ª Qualità	29,34
TC4B	4,6 - 8,0	M5 - 12	M6 - 12	110	300	1ª Qualità	39,66
TC1B	2,6 - 5,5	M3 - 8	M3 - 6	85	180	2ª Qualità	16,82
TC2B	4,6 - 8,0	M5 - 12	M6 - 12	110	300	2ª Qualità	25,19

Ref. TL

TIPO
T

SERIE LUNGA



	CAPACITÀ mm min.-max.	Per codoli di maschi		L1 mm	PESO g	QUALITÀ	TL
		DIN	ISO				€
TL3	2,6 - 5,5	M3 - 8	M3 - 6	250	250	1ª Qualità	46,29
TL4	4,6 - 8,0	M5 - 12	M6 - 12	300	440	1ª Qualità	55,12
TL1	2,6 - 5,5	M3 - 10	M3 - 6	250	250	2ª Qualità	32,54
TL2	4,6 - 8,0	M5 - 12	M6 - 12	300	440	2ª Qualità	38,78

ESPOSITORE IN METACRILATO

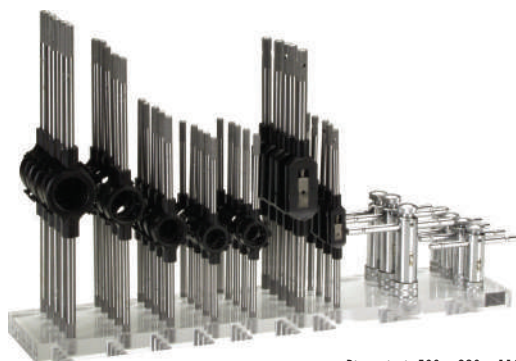

Dimensioni: 500 x 320 x 110 mm

	N° 1 1/2		N° 2			TC1 TC2	GV-01
	5	5	20 x 5	20 x 7	25 x 9		€
GV-01	5	5	5	5	5	4 4	791,29
			30 x 11	38 x 14			
			5	5			

ASSORTIMENTO DI MASCHI E FILIERE HSS IN SCATOLA METALLICA

M3
M12

HSS



Ref. D624

CONTENUTO

					N° Pezzi	1° Qualità €	2° Qualità €
D624	M3 - M4 - M5 - M6 - M8 - M10 - M12	N° 1.1/2	25 x 9	-	30	258,27	234,29

ASSORTIMENTI DI FILIERE HSS IN SCATOLA METALLICA

M3
M12

HSS



Ref. D671

CONTENUTO

				N° Pezzi	1° Qualità €	2° Qualità €	
D671	M3 - M4 - M5 - M6 - M8 - M10 - M12	20 x 5 30 x 11	20 x 7 38 x 14	25 x 9	12	254,76	215,79
D6711 (Sinistra)	M3 - M4 - M5 - M6 - M8 - M10 - M12	20 x 5 30 x 11	20 x 7 38 x 14	25 x 9	12	458,57	388,41

ASSORTIMENTI DI MASCHI E FILIERE HSS E HSSCo IN SCATOLA METALLICA CON GUIDE PER FILIERE

M3
M12

HSS

HSSCo
5%

Ref. D621



Ref. D655

CONTENUTO

							N° Pezzi	1° Qualità €	2° Qualità €
D621	M3 - M4 - M5 - M6 M8 - M10 - M12	2.5 / 3.3 / 4.2 / 5.0 6.8 / 8.5 / 10.2 mm	N° 1 N° 2	20 x 5 20 x 7 25 x 9 30 x 11 38 x 14		TC1	43	517,87	379,58
D652	M3 - M4 - M5 - M6 M8 - M10 - M12	2.5 / 3.3 / 4.2 / 5.0 6.8 / 8.5 / 10.2 mm	N° 1 N° 2	20 x 5 20 x 7 25 x 9 30 x 11 38 x 14		-	42	501,29	360,46
D662	M3-M4-M5-M6-M7 M8-M9-M10-M11-M12	-	N° 1 N° 2	20 x 5 20 x 7 25 x 9 30 x 11 38 x 14		TC1	48	771,48	678,57
D651	M3 - M4 - M5 - M6 M8 - M10 - M12	-	N° 1 N° 2	20 x 5 20 x 7 25 x 9 30 x 11 38 x 14		-	35	395,65	363,99
D655* (HSSCo)	M3 - M4 - M5 - M6 M8 - M10 - M12	2.5 / 3.3 / 4.2 / 5.0 6.8 / 8.5 / 10.2 mm	N° 1 N° 2	20 x 5 20 x 7 25 x 9 30 x 11 38 x 14		TC1	43	826,14	726,70
D621I (Sinistra)	M3 - M4 - M5 - M6 M8 - M10 - M12	2.5 / 3.3 / 4.2 / 5.0 6.8 / 8.5 / 10.2 mm	N° 1 N° 2	20 x 5 20 x 7 25 x 9 30 x 11 38 x 14		TC1	43	932,17	683,24

*

HSSCo
5%

ASSORTIMENTI DI MASCHI E FILIERE HSS E HSSCo IN SCATOLA METALLICA CON GUIDE PER FILIERE

**M3
M12**



HSS

**HSSCo
5%**



Ref. D656



Ref. D657



CONTENUTO

						N° Pezzi	1° Qualità €	2° Qualità €
D656	M3 - M4 - M5 - M6 M8 - M10 - M12	2.5 / 3.3 / 4.2 / 5.0 6.8 / 8.5 / 10.2 mm	N° 1 N° 2	20 x 5 20 x 7 25 x 9 30 x 11 38 x 14	TC1	43	578,71	512,29
D657* (HSSCo)	M3 - M4 - M5 - M6 M8 - M10 - M12	2.5 / 3.3 / 4.2 / 5.0 6.8 / 8.5 / 10.2 mm	N° 1 N° 2	20 x 5 20 x 7 25 x 9 30 x 11 38 x 14	TC1	43	861,50	760,39

* **HSSCo
5%**

ASSORTIMENTI DI MASCHI E FILIERE HSS E HSSCo IN SCATOLA METALLICA

M3
M20M5
M20

HSS

HSSCo
5%

Maschi e Filiere

Verde



Ref. D622



Ref. D623

CONTENUTO

					N° Pezzi	1° Qualità €	2° Qualità €
D622	M3 - M4 - M5 - M6 - M8 - M10 - M12 M14 - M16 - M18 - M20	N° 1 N° 3	20 x 5 20 x 7 25 x 9 30 x 11 38 x 14 45 x 18	TC1 TC2	54	885,75	695,91
D658	M3 - M4 - M5 - M6 - M8 - M10 - M12 M14 - M16 - M18 - M20	N° 1 N° 3	20 x 5 20 x 7 25 x 9 30 x 11 38 x 14 45 x 18	-	52	815,98	629,61
D6221 (Sinistra)	M3 - M4 - M5 - M6 - M8 - M10 - M12 M14 - M16 - M18 - M20	N° 1 N° 3	20 x 5 20 x 7 25 x 9 30 x 11 38 x 14 45 x 18	TC1 TC2	54	1.594,35	1.252,64
D659* (HSSCo)	M3 - M4 - M5 - M6 - M8 - M10 - M12 M14 - M16 - M18 - M20	N° 1 N° 3	20 x 5 20 x 7 25 x 9 30 x 11 38 x 14 45 x 18	-	52	1.839,88	1.618,36
D623	M5 - M6 - M8 - M10 - M12 M14 - M16 - M18 - M20	N° 1 N° 3	20 x 7 25 x 9 30 x 11 38 x 14 45 x 18	TC1 TC2	45	928,65	727,04
D663	M5 - M6 - M7 - M8 - M9 - M10 - M12 M14 - M16 - M18 - M20	N° 1 N° 3	20 x 7 25 x 9 30 x 11 38 x 14 45 x 18	-	51	1.238,09	1.113,64

*

HSSCo
5%

ASSORTIMENTI DI MASCHI E FILIERE HSS IN SCATOLA METALLICA E DI LEGNO

**M1
M10**

**M5
M12**

**M3
M24**

**M5
M30**

HSS

Maschi e Filiere

Verde







Ref. D628

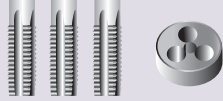

Ref. D626

CONTENUTO

					N° Pezzi	1° Qualità €	2° Qualità €
D626	M1 - M1.2 - M1.4 - M1.7 - M2.0 - M2.3 M2.6 - M3 - M3.5 - M4 - M5 - M6 - M8 - M10	N° 0 N° 1	16 x 5 20 x 5 20 x 7 25 x 9 30 x 11	TC1	64	-	1.158,45
D627	M5 - M6 - M7 - M8 - M9 - M10 - M11 - M12	N° 1 N° 2	20 x 7 25 x 9 30 x 11 38 x 14	TC1	39	-	865,42
D625	M3 - M4 - M5 - M6 - M8 - M10 - M12 - M14 M16 - M18 - M20 - M22 - M24	N° 1 N° 4	20 x 5 20 x 7 25 x 9 30 x 11 38 x 14 45 x 18 55 x 22	-	61	2.044,04	1.508,17
D628	M5 - M6 - M8 - M10 - M12 - M14 - M16 M18 - M20 - M22 - M24 - M27 - M30	N° 1 N° 3 N° 5	20 x 7 25 x 9 30 x 11 38 x 14 45 x 18 55 x 22 65 x 25	-	62	-	2.760,51

ASSORTIMENTI DI MASCHI E FILIERE HSS IN SCATOLA METALLICA

MF

HSS







Ref. D634

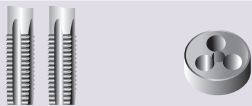

Ref. D636

CONTENUTO

					N° Pezzi	1° Qualità €	2° Qualità €
D634	MF 3 x 0.35 - 4 x 0.5 - 5 x 0.5 MF 6 x 0.75 - 8 x 0.75 - 8 x 1.0 MF 10 x 1.0 - 12 x 1.5	N° 1 N° 2	20 x 5 25 x 9 30 x 11 38 x 10	TC1	31	-	794,00
D635	MF 6 x 0.75 - 8 x 0.75 - 8 x 1.0 - 10 x 1.0 MF 12 x 1.0 - 12 x 1.5 - 14 x 1.25 - 14 x 1.5 MF 16 x 1.5 - 18 x 1.5 - 20 x 1.5	N° 1 N° 3	20 x 7 25 x 9 30 x 11 38 x 10 45 x 14	-	40	1.295,17	1.231,61
D636	MF 6 x 0.75 - 8 x 0.75 - 8 x 1.0 - 10 x 1.0 MF 12 x 1.0 - 12 x 1.5 - 14 x 1.25 - 14 x 1.5 MF 16 x 1.5 - 18 x 1.5 - 20 x 1.5 - 22 x 1.5 MF 24 x 1.5	N° 1 N° 4	20 x 7 25 x 9 30 x 11 38 x 10 45 x 14 55 x 16	-	47	1.776,74	1.642,72

ASSORTIMENTI DI MASCHI E FILIERE HSS IN SCATOLA METALLICA

**BSP
(GAS)**

HSS



Ref. D638

CONTENUTO

						N° Pezzi	1° Qualità €	2° Qualità €
D637	G 1/8 - 1/4 - 3/8 - 1/2 - 3/4 - 1"	N° 1 N° 3 N° 5	30 x 11 38 x 10 45 x 14 55 x 16 65 x 18	-	-	26	1.438,04	1.161,63
D638	G 1/8 - 1/4 - 3/8 - 1/2 - 5/8 - 3/4 - 7/8 - 1"	N° 1 N° 3 N° 5	30 x 11 38 x 10 45 x 14 55 x 16 65 x 18	-	-	32	1.951,57	1.703,58
D639	G 1/4 - 3/8 - 1/2 - 3/4 - 1" - 1".1/4 - 1".1/2	N° 2 N° 4 N° 7	38 x 10 45 x 14 55 x 16 65 x 18 75 x 20 90 x 22	-	-	30	3.600,32	3.037,02

BSW

HSS

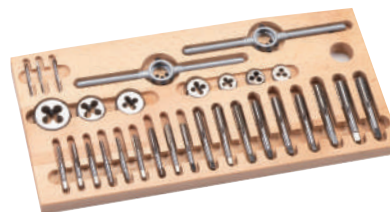

Ref. D640



CONTENUTO

					N° Pezzi	1° Qualità €	2° Qualità €
D640	BSW 1/8 - 3/16 - 1/4 - 5/16 - 3/8 - 7/16 - 1/2	N° 1 N° 2	20 x 5 20 x 7 25 x 9 30 x 11 38 x 14	TC1	36	802,23	685,78
D641	BSW 1/4 - 5/16 - 3/8 - 7/16 - 1/2	N° 1 N° 2	20 x 7 25 x 9 30 x 11 38 x 14	TC1	27	661,33	557,02
D642	BSW 1/4 - 5/16 - 3/8 - 7/16 - 1/2 - 5/8 - 3/4	N° 1 N° 3	20 x 7 25 x 9 30 x 11 38 x 14 45 x 18	-	35	1.183,54	1.079,93
D643	BSW 1/4 - 5/16 - 3/8 - 7/16 1/2 - 5/8 - 3/4 - 7/8 - 1"	N° 1 N° 4	20 x 7 25 x 9 30 x 11 38 x 14 45 x 18 55 x 22	-	44	1.673,80	1.469,54
D646	BSW 1/4 - 5/16 - 3/8 - 7/16 1/2 - 5/8 - 3/4 - 7/8 - 1" - 1".1/8 1".1/4 - 1".3/8 - 1".1/2	N° 1 N° 3 N° 5	20 x 7 25 x 9 30 x 11 38 x 14 45 x 18 55 x 22 65 x 25	-	62	-	4.465,59

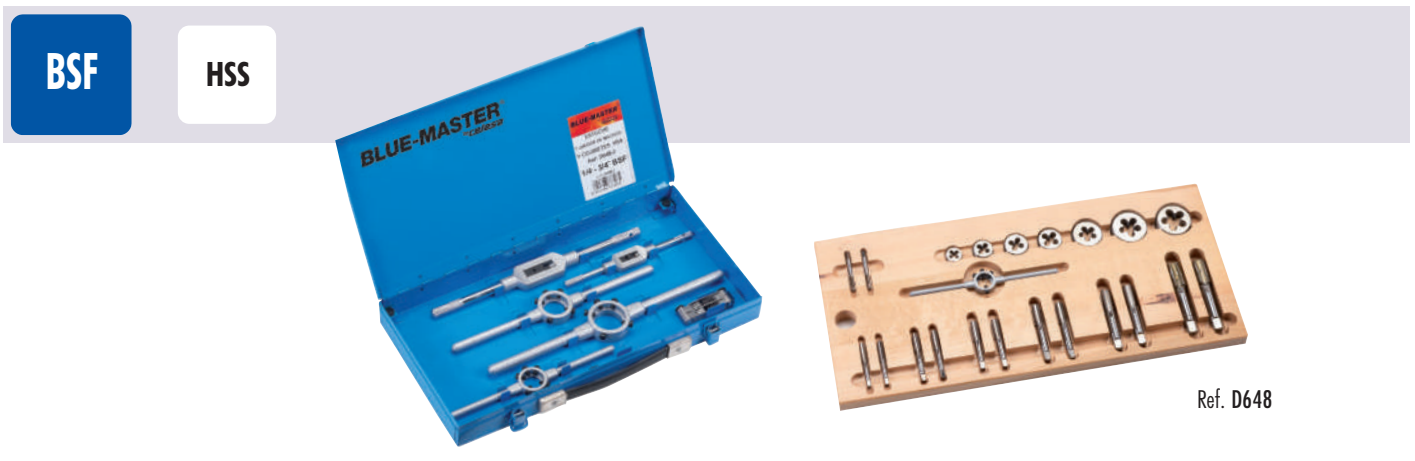
ASSORTIMENTI DI MASCHI E FILIERE HSS IN SCATOLA METALLICA



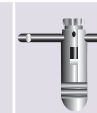

CONTENUTO

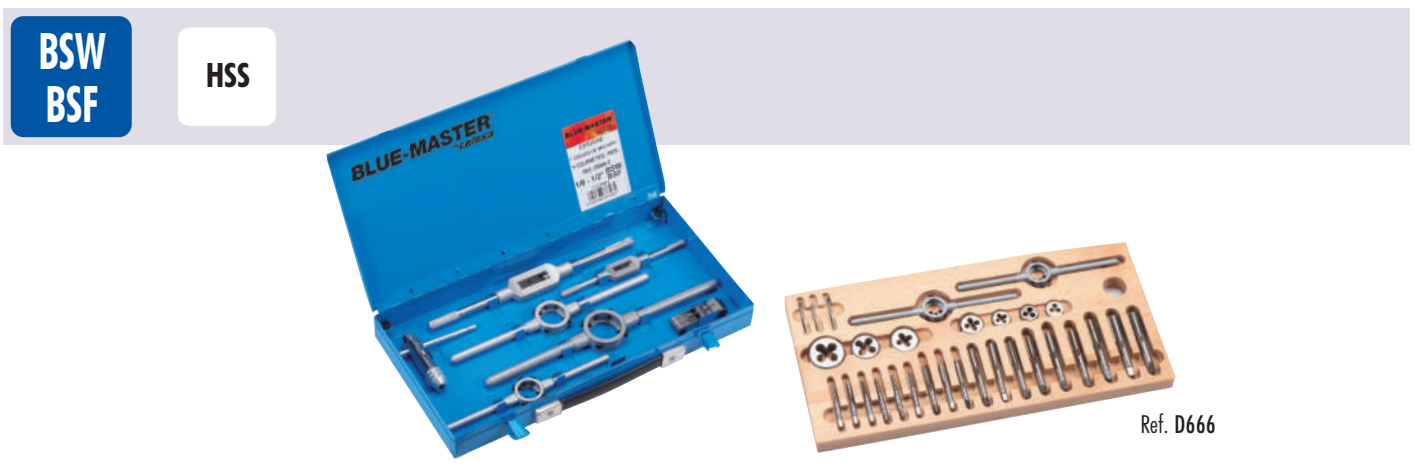
					N° Pezzi	1° Qualità €	2° Qualità €
D664	BSF 1/4 - 5/16 - 3/8 - 7/16 - 1/2	N° 1 N° 2	20 x 7 25 x 9 30 x 11 38 x 10	TCl	22	739,56	650,51
D648	BSF 1/4 - 5/16 - 3/8 - 7/16 - 1/2 - 5/8 - 3/4	N° 1 N° 3	20 x 7 25 x 9 30 x 11 38 x 10 45 x 14	-	28	1.148,09	1.079,93
D665	BSF 1/4 - 5/16 - 3/8 - 7/16 1/2 - 5/8 - 3/4 - 7/8 - 1"	N° 1 N° 4	20 x 7 25 x 9 30 x 11 38 x 10 45 x 14 55 x 16	-	35	1.948,12	1.713,55

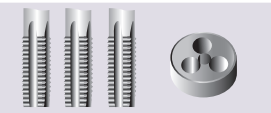

CONTENUTO

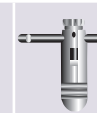
					N° Pezzi	1° Qualità €	2° Qualità €
D666	BSW 1/4 - 5/16 - 3/8 - 7/16 - 1/2 - 5/8 - 3/4 BSF 1/4 - 5/16 - 3/8 - 7/16 - 1/2 - 5/8 - 3/4	N° 1 N° 3	20 x 7 25 x 9 30 x 11 38 x 14 45 x 18	-	63	2.200,66	1.935,68

ASSORTIMENTI DI MASCHI E FILIERE HSS IN SCATOLA METALLICA





NPT

HSS



Ref. D660

CONTENUTO

						N° Pezzi	1ª Qualità €	2ª Qualità €
D660	NPT 1/8 - 1/4 - 3/8 - 1/2 - 3/4 - 1"		N°1 N°3 N°5	30 x 11 38 x 14 45 x 18 55 x 22 65 x 25	-	20	2.080,19	1.973,16
D661	NPT 1/8 - 1/4 - 3/8 - 1/2 - 3/4 1" - 1".1/4 - 1".1/2 - 2"		N° 2 N° 4 N° 7	30 x 11 38 x 14 45 x 18 55 x 22 65 x 25 75 x 30 90 x 36 105 X 36	-	29	6.227,02	5.850,26





UNC

HSS

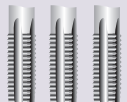

Ref. D650

CONTENUTO

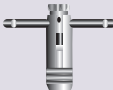
						N° Pezzi	1ª Qualità €	2ª Qualità €
D650	UNC 1/4 - 5/16 - 3/8 - 7/16 - 1/2		N° 1 N° 2	20 x 7 25 x 9 30 x 11 38 x 14	TC1	27	806,09	723,50
D667	UNC 1/4 - 5/16 - 3/8 - 7/16 - 1/2 - 5/8 - 3/4		N° 1 N° 2	20 x 7 25 x 9 30 x 11 38 x 14 45 x 18	-	35	1.298,75	1.142,36
D654	UNC 1/4 - 5/16 - 3/8 - 7/16 1/2 - 5/8 - 3/4 - 7/8 - 1"		N° 1 N° 4	20 x 7 25 x 9 30 x 11 38 x 14 45 x 18 55 x 22	-	44	2.095,65	1.961,26
D668	UNC 1/4 - 5/16 - 3/8 - 7/16 - 1/2 - 5/8 - 3/4 7/8 - 1" - 1.1/8 - 1.1/4 - 1".3/8 - 1".1/2"		N° 1 N° 3 N° 6	20 x 7 25 x 9 30 x 11 38 x 14 45 x 18 55 x 22 65 x 25	-	62	4.906,35	4.315,59

ASSORTIMENTI DI MASCHI E FILIERE HSS IN SCATOLA METALLICA





UNF

HSS

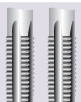

Ref. D644

CONTENUTO

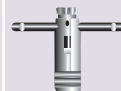
						N° Pezzi	1° Qualità €	2° Qualità €
D644	UNF 1/4 - 5/16 - 3/8 - 7/16 - 1/2		N° 1 N° 2	20 x 7 25 x 9 30 x 11 38 x 10	TC1	22	631,65	547,58
D669	UNF 1/4-5/16 -3/8 -7/16 -1/2 -5/8 -3/4		N° 1 N° 3	20 x 7 25 x 9 30 x 11 38 x 10 45 x 14	-	28	1.190,50	1.047,16
D645	UNF 1/4 - 5/16 - 3/8 - 7/16 - 1/2 - 5/8 3/4 - 7/8 - 1"		N° 1 N° 4	20 x 7 25 x 9 30 x 11 38 x 10 45 x 14 55 x 16	-	34	1.459,80	1.323,60



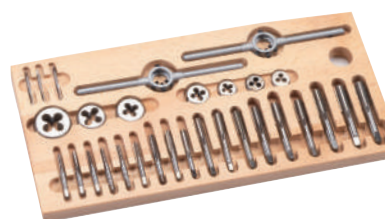

UNC
UNF

HSS

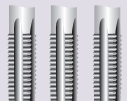

Ref. D670

CONTENUTO

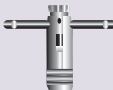
						N° Pezzi	1° Qualità €	2° Qualità €
D670	UNC 1/4 - 5/16 - 3/8 - 7/16 - 1/2 - 5/8 - 3/4 UNF 1/4 - 5/16 - 3/8 - 7/16 - 1/2 - 5/8 - 3/4		N° 1 N° 3	20 x 7 25 x 9 30 x 11 38 x 14 45 x 18	-	35	2.200,66	1.935,68

ASSORTIMENTI DI MASCHI A MANO HSS E TIN IN SCATOLE METALLICHE



Ref. JMB0



Ref. JMB2



Ref. JMBT2

CONTENUTO

					HSS		TiN*
					€		€
JMB2	M3 - M4 - M5 - M6 M8 - M10 - M12	-	-	-	171,76	JMBT2	339,25
JMB0	M3 - M4 - M5 - M6 M8 - M10 - M12	2.5 / 3.3 / 4.2 / 5.0 6.8 / 8.5 / 10.2 mm	-	-	195,94	JMBT0	380,71
JMB1	M3 - M4 - M5 - M6 M8 - M10 - M12	2.5 / 3.3 / 4.2 / 5.0 6.8 / 8.5 / 10.2 mm	N° 1.1/2	-	216,57	JMBT1	399,62
JMB5	M3 - M4 - M5 - M6 M8 - M10 - M12	2.5 / 3.3 / 4.2 / 5.0 6.8 / 8.5 / 10.2 mm	N° 1.1/2	TC1	233,18	JMBT5	418,75
JMBI2 (Sinistra)	M3 - M4 - M5 - M6 M8 - M10 - M12	-	-	-	309,17	JMBIT2	610,65
JMBI0 (Sinistra)	M3 - M4 - M5 - M6 M8 - M10 - M12	2.5 / 3.3 / 4.2 / 5.0 6.8 / 8.5 / 10.2 mm	-	-	352,69	JMBIT0	685,28
JMBI1 (Sinistra)	M3 - M4 - M5 - M6 M8 - M10 - M12	2.5 / 3.3 / 4.2 / 5.0 6.8 / 8.5 / 10.2 mm	N° 1.1/2	-	389,82	JMBIT1	719,31

ASSORTIMENTI DI MASCHI FINITORI A MANO HSS E TIN IN SCATOLE METALLICHE



Ref. JMB3



Ref. JMB4

CONTENUTO

3°					HSS		TiN*
					€		€
JMB3	M3 - M4 - M5 - M6 M8 - M10 - M12	-	-	-	83,78	JMBT3	104,37
JMB4	M3 - M4 - M5 - M6 M8 - M10 - M12	2.5 / 3.3 / 4.2 / 5.0 6.8 / 8.5 / 10.2 mm	-	-	104,27	JMBT4	137,87
JMB7	M3 - M4 - M5 - M6 M8 - M10 - M12	2.5 / 3.3 / 4.2 / 5.0 6.8 / 8.5 / 10.2 mm	N° 1.1/2	-	119,33	JMBT7	191,23
JMB6	M3 - M4 - M5 - M6 M8 - M10 - M12	2.5 / 3.3 / 4.2 / 5.0 6.8 / 8.5 / 10.2 mm	N° 1.1/2	TC1	129,20	JMBT6	203,83
JMBI3 (Sinistra)	M3 - M4 - M5 - M6 M8 - M10 - M12	-	-	-	150,80	JMBIT3	187,87
JMBI4 (Sinistra)	M3 - M4 - M5 - M6 M8 - M10 - M12	2.5 / 3.3 / 4.2 / 5.0 6.8 / 8.5 / 10.2 mm	-	-	187,68	JMBIT4	248,16



ASSORTIMENTI DI MASCHI A MANO HSSCO IN SCATOLE METALLICHE

HSSCo
5%

Ref. JMBX0

CONTENUTO

INOX	 MOX	 HSSCo			€
JMBX0	M3 - M4 - M5 - M6 M8 - M10 - M12	2.5 / 3.3 / 4.2 / 5.0 6.8 / 8.5 / 10.2 mm	-	-	303,01
JMBX1	M3 - M4 - M5 - M6 M8 - M10 - M12	2.5 / 3.3 / 4.2 / 5.0 6.8 / 8.5 / 10.2 mm	N° 1.1/2	-	318,89
JMBX2	M3 - M4 - M5 - M6 M8 - M10 - M12	-	-	-	286,53

CONTENUTO

1100 N/mm ²	 MOMD	 HSSCo			€
JMBMD0	M3 - M4 - M5 - M6 M8 - M10 - M12	2.5 / 3.3 / 4.2 / 5.0 6.8 / 8.5 / 10.2 mm	-	-	316,43
JMBMD1	M3 - M4 - M5 - M6 M8 - M10 - M12	2.5 / 3.3 / 4.2 / 5.0 6.8 / 8.5 / 10.2 mm	N° 1.1/2	-	332,88
JMBMD2	M3 - M4 - M5 - M6 M8 - M10 - M12	-	-	-	301,61

SET DI FILIERE HSS IN SCATOLE METALLICHE



Ref. C5B3



CONTENUTO

		HSS €
C5B3	M3 - M4 - M5 - M6 - M8 - M10 - M12	153,40
C5B3I (Sinistra)	M3 - M4 - M5 - M6 - M8 - M10 - M12	276,12

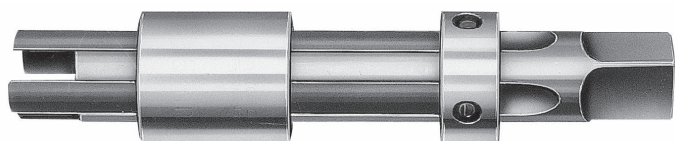

ESTRATTORE DI MASCHI ROTTI PER MASCHI A SCANALATURE DRITTE – NON ELICOIDALI



ESTRATTORI SCIOLTI

Ø MASCHIO DA ESTRARRE		MASCHI A MANO	MASCHI A MACCHINA	€/ U.tà
BSW UNC	M			ESTRATTORE COMPLETO
--	M3		W10043	48,19
1/8	M3,2		W10053	48,19
--	M3,5		W10063	48,19
5/32	M4		W10083	48,19
3/16	M5		W10103	48,19
--	M5,5	W10124	W10123	48,19
1/4	M6		W10253	49,62
5/16	M8	W10314	W10313	51,99
--	M9	W10374	W10373	51,49
3/8	M10	W10404	W10373	51,49
7/16	M11	W10434	W10433	54,36
1/2	M12	W10504	W10503	58,11
9/16	M14	W10564	W10563	80,33
5/8	M16	W10624	W10623	87,43
--	M18	W10684	W10753	108,33
3/4	M20	W10754	W10753	108,33
7/8	M22	W10874	W10873	118,52
1"	M25	W11004	W11003	132,18

ASTA DI RICAMBIO

MASCHI A MANO	MASCHI A MACCHINA	€/ U.tà
		ASTA EXTRA
	W12043	2,55
	W12053	2,55
	W12063	2,55
	W12083	2,55
	W12103	3,83
	W12123	3,83
	W12253	4,67
W12314	W12313	5,26
W12374		5,26
W12404	W12373	5,44
W12434	W12433	5,51
W12504	W12503	6,94
W12564	W12563	7,76
W12624	W12623	9,90
W12684		9,90
W12754	W12753	10,49
W12874	W12873	13,59
W13004	W13003	22,60

3 SEMPLICI PASSI PER L'ESTRAZIONE DI MASCHI ROTTI A SCANALATURE DRITTE

Rimuovere i trucioli del maschio rotto. Introdurre le aste dell'estrattore nelle scanalature del maschio rotto con fermezza fino in fondo.

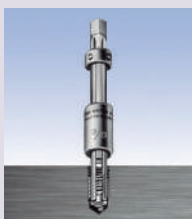

Spingere il supporto verso il basso, fino a toccare il maschio rotto. Far scivolare la boccola verso il basso, fino a toccare la superficie di lavoro.

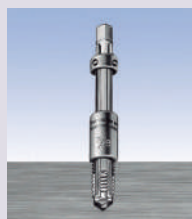

Applicare un giramaschi all'attacco quadro dell'estrattore. Girare a sinistra più volte fino a sbloccarlo, allora estrarre il maschio rotto.

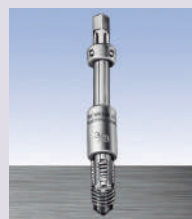

SET DI ESTRATTORI PER MASCHI ROTTI (SCANALATURE DRITTE)



N° CANALI	MISURE INCLUSE PER MASCHI A MACCHINA E A MANO E: 3 E 4 CANALI	
W180013	3	M5- M6- M8- M10- M11- M12
W180014	4	3/16 - 1/4 - 5/16 - 3/8 - 7/16 - 1/2
W180023	3	M6- M8 -M10- M11- M12- M16
W180024	4	1/4 - 5/16 - 3/8 - 7/16 - 1/2 - 5/8
W180153	3	M3- M3,2- M3,5- M4-M5- M5,50- M6- M8
W180154	4	M9- M10- M12- M16- M18- M22- M25
		334,11
		375,91
		1.051,49

MASCHI PER FILETTARE A MACCHINA HSSCo

M
MF

DIN 13

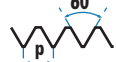

60°

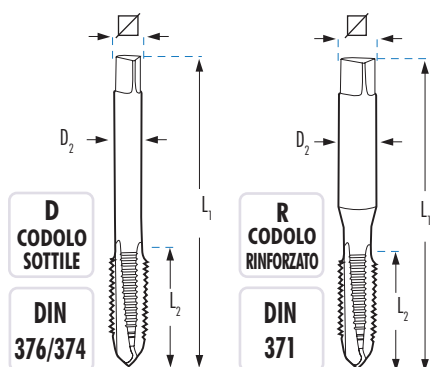
HSSCo
5%TOL
6HVc
12 m/min

D CODOLO SOTTILE DIN 376/374	Ø	R CODOLO RINFORZATO DIN 371	L1 x L2 x D2 x ∇ mm	M1D	M2D	M3D	M4D	M1R	M2R	M3R	M4R
				FORMA C €	FORMA B €	15° €	35° €	FORMA C €	FORMA B €	15° €	35° €
M 1x0,25	0,75	R	40 x 5,5 x 2,5 x 2,1					44,01			
M 1,1x0,25	0,85	R	40 x 6 x 2,5 x 2,1					42,81			
M 1,2x0,25	0,95	R	40 x 6 x 2,5 x 2,1					40,60			
M 1,4x0,30	1,10	R	40 x 7 x 2,5 x 2,1					40,60			
M 1,6x0,35	1,25	R	40 x 8 x 2,5 x 2,1					39,88			
M 1,7x0,35	1,35	R	40 x 8 x 2,5 x 2,1					38,40			
M 1,8x0,35	1,45	R	40 x 8 x 2,5 x 2,1					37,47			
M 2x0,40	1,60	R	40 x 8 x 2,8 x 2,1					18,05	19,24	22,33	21,13
M 2,2x0,45	1,75	R	40 x 9 x 2,8 x 2,1					19,49			
M 2,3x0,40	1,90	R	40 x 9 x 2,8 x 2,1					17,96			
M 2,5x0,45	2,05	R	50 x 9 x 2,8 x 2,1					18,05	19,24	30,24	21,13
M 2,6x0,45	2,10	R	50 x 9 x 2,8 x 2,1					17,41	19,58		37,84
M 3x0,50	2,50	R D	56 x 11 x 3,5 x 2,7 56 x 11 x 2,2 x 1,8	10,55	11,50	16,39	13,84	11,95*	12,02	16,37	15,53
M 3x0,60	2,40	R	56 x 11 x 3,5 x 2,7					21,24	23,15		29,48
M 3,5x0,60	2,90	R D	56 x 12 x 4,0 x 3,0 56 x 12 x 2,5 x 2,1					17,37	18,05	22,48	21,89
M 3,5x0,75	2,75	R	56 x 12 x 4,0 x 3,0					22,11			
M 4x0,50	3,50	R D	63 x 13 x 4,5 x 3,4 63 x 13 x 2,8 x 2,1	22,67	25,66		27,42	25,00	26,79		31,01
M 4x0,70	3,30	R D	63 x 13 x 4,5 x 3,4 63 x 13 x 2,8 x 2,1	10,75	11,67	16,13	13,71	13,34*	12,82	16,54	15,55
M 4x0,75	3,25	R	63 x 13 x 4,5 x 3,4					18,30	20,30		
M 4x0,80	3,20	R	63 x 13 x 4,5 x 3,4					97,18			
M 4,5x0,50	4,00	R	70 x 14 x 6,0 x 4,9						31,16		
M 4,5x0,75	3,75	R	70 x 14 x 6,0 x 4,9					23,47	25,83		
M 5x0,50	4,50	R D	70 x 14 x 6,0 x 4,9 70 x 11 x 3,5 x 2,7	23,35	26,40		27,71	25,76	27,51		33,09
M 5x0,75	4,50	R D	74 x 14 x 6,0 x 4,9 70 x 16 x 3,5 x 2,7					23,07	26,09		32,87
M 5x0,80	4,20	R D	70 x 16 x 6,0 x 4,9 70 x 16 x 3,5 x 2,7	10,75	11,77	15,47	13,17	12,17*	12,90	16,71	14,91
M 5x0,90	4,10	R D	70 x 15 x 6,0 x 4,9 70 x 16 x 3,5 x 2,7					19,35	24,92		
M 5x1,00	4,00	R	72 x 17 x 6,0 x 4,9					51,81			
M 5,5x0,90	4,60	R	80 x 17 x 6,0 x 4,9					51,81			
M 6x0,50	5,50	R D	80 x 17 x 6,0 x 4,9 80 x 13 x 4,5 x 3,4	26,11	26,54		28,99	32,46			
M 6x0,75	5,25	R D	80 x 13 x 6,0 x 4,9 80 x 13 x 4,5 x 3,4	18,21	21,89		24,63	21,02	24,51		29,41
M 6x1,00	5,00	R D	80 x 19 x 6,0 x 4,9 80 x 19 x 4,5 x 3,4	12,25	12,90	17,42	14,43	13,43*	13,67	17,79	16,35

* Consultare il prezzo delle serie di maschi e filiere a sinistra disponibili a Pag.215

MASCHI PER FILETTARE A MACCHINA HSSCo











M	L1 x L2 x D2 x ∇ mm	R	FORMA C	FORMA B	15°	35°	FORMA C	FORMA B	15°	35°
M 6x1,25	4,75	R 80 x 17 x 6,0 x 4,9					50,90			
M 7x0,75	6,25	D 80 x 13 x 5,5 x 4,3	23,45	26,42		28,99				
M 7x1,00	6,00	R 80 x 19 x 7,0 x 5,5 D 80 x 19 x 5,5 x 4,3	16,78	19,40	20,97	20,18	17,97 *	19,49	23,70	23,45
M 8x0,50	7,50	D 80 x 13 x 6 x 4,9	32,74							
M 8x0,75	7,25	D 80 x 13 x 6 x 4,9	22,85	27,38		28,99				
M 8x1,00	7,00	D 90 x 20 x 6 x 4,9	19,40	22,27	25,70	23,75				
M 8x1,25	6,80	R 90 x 22 x 8 x 6,2 D 90 x 22 x 6 x 4,9	13,73	14,63	19,81	17,01	15,65 *	15,66	19,45	19,11
M 8x1,50	6,50	D 90 x 20 x 6 x 4,9	92,42							
M 9x1,00	8,00	D 90 x 20 x 7 x 5,5	26,69	26,52		29,81				
M 9x1,25	7,80	R 90 x 22 x 9 x 7,0 D 90 x 22 x 7 x 5,5	22,69	24,78	28,91	29,33	24,99	22,31	32,36	27,42
M 10x0,50	9,50	D 90 x 20 x 7 x 5,5	91,57							
M 10x0,75	9,25	D 90 x 16 x 7 x 5,5	31,03	30,66		35,03				
M 10x1,00	9,00	D 90 x 16 x 7 x 5,5	21,47	24,77	30,35	30,02				
M 10x1,25	8,80	D 100 x 22 x 7 x 5,5	24,59	29,58	33,06	32,70				
M 10x1,50	8,50	R 100 x 24 x 10 x 8,0 D 100 x 24 x 7 x 5,5	15,81	17,69	23,57	20,37	17,41 *	19,28	22,40	22,64
M 11x1,00	10,00	D 90 x 20 x 8 x 6,2	35,73	38,29	96,82	45,91				
M 11x1,25	9,75	D 100 x 22 x 8 x 6,2	36,84	40,95	96,82	45,41				
M 11x1,50	9,50	D 100 x 24 x 8 x 6,2	28,77	32,78	70,60	65,44				
M 12x0,75	11,25	D 100 x 22 x 9 x 7,0	56,43							
M 12x1,00	11,00	D 100 x 22 x 9 x 7,0	29,23	32,52	37,43	37,02				
M 12x1,25	10,75	D 100 x 22 x 9 x 7,0	29,58	32,85	35,84	35,45				
M 12x1,50	10,50	D 100 x 22 x 9 x 7,0	26,44*	29,30	34,47	34,09				
M 12x1,75	10,20	D 110 x 28 x 9 x 7,0	19,07*	22,07	28,46	25,99				
M 13x0,75	12,25	D 100 x 22 x 11 x 9,0	98,47							
M 13x1,00	12,00	D 100 x 22 x 11 x 9,0	52,14	53,14						
M 13x1,25	11,75	D 100 x 22 x 11 x 9,0	52,14	59,05						
M 13x1,50	11,50	D 100 x 22 x 11 x 9,0	52,14	53,14						
M 13x1,75	11,25	D 100 x 28 x 11 x 9,0	49,86	59,05						
M 14x0,75	13,25	D 100 x 22 x 11 x 9,0	98,47							
M 14x1,00	13,00	D 100 x 22 x 11 x 9,0	42,74	49,84	57,73	55,97				
M 14x1,25	12,80	D 100 x 22 x 11 x 9,0	37,76	43,70	52,94	52,36				
M 14x1,50	12,50	D 100 x 22 x 11 x 9,0	31,50*	34,69	41,75	41,29				
M 14x2,00	12,00	D 110 x 30 x 11 x 9,0	31,28*	33,60	40,28	38,79				
M 15x1,00	14,00	D 100 x 22 x 12 x 9,0	59,82	58,40		64,71				
M 15x1,25	13,75	D 100 x 22 x 12 x 9,0	64,07	69,36						
M 15x1,50	13,50	D 100 x 22 x 12 x 9,0	51,22	58,40	143,67	64,55				
M 15x2,00	13,00	D 110 x 30 x 12 x 9,0	62,69	68,97						
M 16x1,00	15,00	D 100 x 22 x 12 x 9,0	53,17	59,16	80,80	64,50				
M 16x1,25	14,75	D 100 x 22 x 12 x 9,0	56,98	59,68	89,87	64,77				
M 16x1,50	14,50	D 100 x 22 x 12 x 9,0	37,24*	43,39	52,02	51,46				
M 16x2,00	14,00	D 110 x 32 x 12 x 9,0	36,80*	37,49	45,92	44,76				
M 17x1,00	16,00	D 100 x 22 x 12 x 9,0	112,17							
M 17x1,25	15,75	D 100 x 22 x 12 x 9,0	112,17							
M 17x1,50	15,50	D 100 x 22 x 12 x 9,0	112,17							
M 18x1,00	17,00	D 110 x 25 x 14 x 11,0	59,55	69,36		78,94				
M 18x1,25	16,75	D 110 x 25 x 14 x 11,0	78,25							
M 18x1,50	16,50	D 110 x 25 x 14 x 11,0	49,29*	54,24	63,92	62,19				
M 18x2,00	16,00	D 125 x 30 x 14 x 11,0	60,91	74,25	126,49	79,46				

* Consultare il prezzo delle serie di maschi e filiere a sinistra disponibili a Pag.215

MASCHI PER FILETTARE A MACCHINA HSSCo

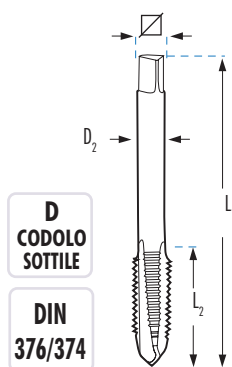
M
MFHSSCo
5%TOL
6HD
CODOLO
SOTTILEDIN
376/374Vc
12 m/min

M	L1 x L2 x D2 x ∇ mm	D	FORMA C	FORMA B	FORMA 15°	FORMA 35°				
							€	€	€	€
M 18x2,50	15,50	D 125 x 34 x 14 x 11,0	49,96*	53,40	61,80	63,08				
M 19x1,00	18,00	D 110 x 22 x 14 x 11,0	147,39							
M 19x1,25	17,75	D 110 x 25 x 14 x 11,0	145,96							
M 19x1,50	17,50	D 110 x 25 x 14 x 11,0	144,66							
M 20x1,00	19,00	D 125 x 25 x 16 x 12,0	69,03	83,30		88,87				
M 20x1,25	18,75	D 125 x 25 x 16 x 12,0	66,81							
M 20x1,50	18,50	D 125 x 25 x 16 x 12,0	55,83*	61,34	71,84	71,05				
M 20x2,00	18,00	D 140 x 32 x 16 x 12,0	69,03	80,45		89,43				
M 20x2,50	17,50	D 140 x 34 x 16 x 12,0	56,36*	62,53	65,96	67,32				
M 21x1,00	20,00	D 125 x 25 x 16 x 12,0	213,98							
M 21x1,25	19,75	D 125 x 25 x 16 x 12,0	213,98							
M 21x1,50	19,50	D 125 x 25 x 16 x 12,0	204,34							
M 22x1,00	21,00	D 125 x 25 x 18 x 14,5	86,19	99,17		107,17				
M 22x1,25	20,75	D 125 x 25 x 18 x 14,5	147,39							
M 22x1,50	20,50	D 125 x 25 x 18 x 14,5	67,19	73,91	78,81	74,16				
M 22x2,00	20,00	D 140 x 32 x 18 x 14,5	86,19	102,77		107,17				
M 22x2,50	19,50	D 140 x 34 x 18 x 14,5	68,22*	75,02	78,21	82,05				
M 23x1,00	22,00	D 125 x 25 x 18 x 14,5	208,05							
M 23x1,50	21,50	D 125 x 25 x 18 x 14,5	208,05							
M 24x1,00	23,00	D 140 x 25 x 18 x 14,5	96,04	113,90		130,29				
M 24x1,25	22,75	D 140 x 25 x 18 x 14,5	213,98							
M 24x1,50	22,50	D 140 x 28 x 18 x 14,5	77,96	90,87	105,33	104,19				
M 24x2,00	22,00	D 140 x 28 x 18 x 14,5	99,46*	114,87		119,39				
M 24x3,00	21,00	D 160 x 38 x 18 x 14,5	81,67*	88,38	94,28	99,74				
M 25x1,00	24,00	D 140 x 28 x 18 x 14,5	172,80							
M 25x1,25	23,75	D 140 x 28 x 18 x 14,5	289,42							
M 25x1,50	23,50	D 140 x 28 x 18 x 14,5	121,43	120,97						
M 25x2,00	23,00	D 140 x 28 x 18 x 14,5	276,80	287,26						
M 26x1,00	25,00	D 140 x 28 x 18 x 14,5	142,20							
M 26x1,50	24,50	D 140 x 28 x 18 x 14,5	101,62	116,81	197,33	130,14				
M 26x2,00	24,00	D 140 x 28 x 18 x 14,5	119,95	121,79		126,35				
M 27x1,00	26,00	D 140 x 28 x 20 x 16,0	137,25	142,21						
M 27x1,50	25,50	D 140 x 28 x 20 x 16,0	114,80	128,91	286,79	158,14				
M 27x2,00	25,00	D 140 x 28 x 20 x 16,0	126,11*	150,41						

* Consultare il prezzo delle serie di maschi e filiere a sinistra disponibili a Pag.215

MASCHI PER FILETTARE A MACCHINA HSSCo

**M
MF**

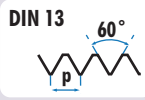

HSSCo
5%

TOL
6H



D
CODOLO
SOTTILE

DIN
376/374



Maschi e Filiere

Rosa



			L1 x L2 x D2 x \square mm	M1D	M2D	M3D	M4D
				FORMA C €	FORMA B €	15° €	35° €
M 27x3,00	24,00	D	160 x 36 x 20 x 16	101,96 *	111,79	122,98	122,72
M 28x1,00	27,00	D	140 x 28 x 20 x 16	276,80			
M 28x1,50	26,50	D	140 x 28 x 20 x 16	114,80	133,58	149,34	140,02
M 28x2,00	26,00	D	140 x 28 x 20 x 16	137,76	145,23	176,01	157,76
M 30x1,00	29,00	D	150 x 28 x 22 x 18	155,64	161,98		177,20
M 30x1,50	28,50	D	150 x 28 x 22 x 18	119,65	139,58	161,97	160,19
M 30x2,00	28,00	D	150 x 28 x 22 x 18	144,82 *	162,92		177,62
M 30x3,50	26,50	D	180 x 40 x 22 x 18	130,64 *	143,64	157,61	157,28
M 32x1,00	31,00	D	150 x 28 x 22 x 18	355,41	377,39		
M 32x1,50	30,50	D	150 x 28 x 22 x 18	151,42	176,21	199,53	
M 32x2,00	30,00	D	150 x 28 x 22 x 18	172,64	202,38		
M 33x1,00	32,00	D	160 x 30 x 25 x 20	339,91			
M 33x1,50	31,50	D	160 x 30 x 25 x 20	174,11	191,77		214,95
M 33x2,00	31,00	D	160 x 30 x 25 x 20	195,70	195,21		221,49
M 33x3,50	29,50	D	180 x 40 x 25 x 20	156,98 *	180,65		200,37
M 34x1,50	32,50	D	170 x 30 x 28 x 22	193,91	201,46		
M 34x2,00	32,00	D	160 x 30 x 28 x 22	423,51			
M 35x1,50	33,50	D	170 x 30 x 28 x 22	195,91	210,24		224,11
M 35x2,00	33,00	D	170 x 30 x 28 x 22	376,32	414,29		
M 36x1,50	34,50	D	170 x 30 x 28 x 22	182,94	229,26		267,25
M 36x2,00	34,00	D	170 x 30 x 28 x 22	233,37	238,99		
M 36x3,00	33,00	D	200 x 50 x 28 x 22	250,40	239,44		279,34
M 36x4,00	32,00	D	200 x 50 x 28 x 22	187,19 *	220,75	256,40	245,32
M 38x1,50	36,50	D	170 x 30 x 28 x 22	195,03	232,93		
M 38x2,00	36,00	D	170 x 32 x 28 x 22	439,40	483,38		
M 39x1,50	37,50	D	170 x 32 x 32 x 24	324,83			
M 39x2,00	37,00	D	170 x 32 x 32 x 24	324,83			
M 39x3,00	36,00	D	200 x 47 x 32 x 24	424,23			
M 39x4,00	35,00	D	200 x 50 x 32 x 24	233,21	256,97		273,08
M 40x1,50	38,50	D	170 x 30 x 32 x 24	255,01	290,92		
M 40x2,00	38,00	D	170 x 30 x 32 x 24	325,71			
M 40x3,00	37,00	D	200 x 47 x 32 x 24	283,86	292,10		
M 42x1,50	40,50	D	170 x 30 x 32 x 24	278,26	288,25		
M 42x2,00	40,00	D	170 x 30 x 32 x 24	372,62			
M 42x3,00	39,00	D	200 x 45 x 32 x 24	322,93	310,33		
M 42x4,50	37,50	D	200 x 56 x 32 x 24	269,90	299,18		396,63
M 45x1,50	43,50	D	180 x 32 x 36 x 29	332,33	387,47		
M 45x2,00	43,00	D	180 x 32 x 36 x 29	431,45			
M 45x3,00	42,00	D	200 x 47 x 36 x 29	431,45			
M 45x4,50	40,50	D	220 x 58 x 36 x 29	327,58	360,32		
M 48x1,50	46,50	D	190 x 32 x 36 x 29	327,58			
M 48x2,00	46,00	D	190 x 32 x 36 x 29	540,29			
M 48x3,00	45,00	D	220 x 52 x 36 x 29	522,83			
M 48x5,00	43,00	D	250 x 65 x 36 x 29	402,84	443,09		
M 50x1,50	48,50	D	190 x 32 x 36 x 29	397,03			
M 52x1,50	50,50	D	190 x 32 x 40 x 32	387,86			
M 52x2,00	50,00	D	190 x 32 x 40 x 32	650,61			
M 52x3,00	49,00	D	225 x 50 x 40 x 32	668,66			
M 52x5,00	47,00	D	250 x 65 x 40 x 32	437,31	491,53		

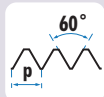
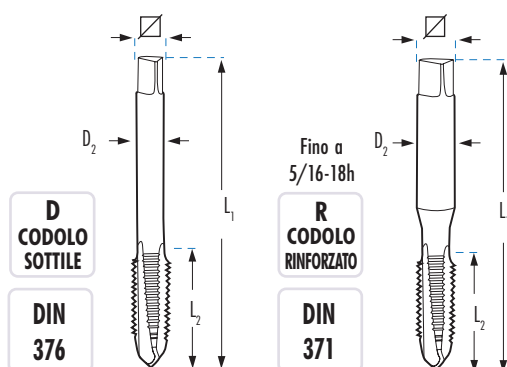

* Consultare il prezzo delle serie di maschi e filiere a sinistra disponibili a Pag.215

MASCHI PER FILETTARE A MACCHINA HSSCo

UNC

HSSCo
5%TOL
2BVc
12 m/min

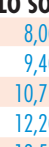
	D1 mm		L1 x L2 x D2 x ∇ mm	M1R	M2R	M4R
				FORMA C	FORMA B	 35° €
				€	€	€
UNC n° 4-40h	2,84	2,25	R 56 x 11 x 3,5 x 2,7	15,09	17,96	22,61
UNC n° 5-40h	3,17	2,60	R 56 x 11 x 3,5 x 2,7	15,65	18,77	22,61
UNC n° 6-32h	3,50	2,75	R 56 x 12 x 4,0 x 3,0	15,66	18,84	23,57
UNC n° 8-32h	4,17	3,50	R 63 x 13 x 4,5 x 3,4	15,66	18,84	22,54
UNC n° 10-24h	4,83	3,90	R 70 x 15 x 6,0 x 4,9	15,65	18,77	23,64
UNC n° 12-24h	5,49	4,50	R 80 x 16 x 6,0 x 4,9	16,42	18,77	22,73
UNC 1/4-20h	6,35	5,10	R 80 x 17 x 7,0 x 5,5	17,15	18,70	23,79
UNC 5/16-18h	7,94	6,60	R 90 x 20 x 8,0 x 6,2	21,40	23,59	28,67

	D1 mm		L1 x L2 x D2 x ∇ mm	M1D	M2D	M4D
				FORMA C	FORMA B	 35° €
				€	€	€
UNC 3/8-16h	9,52	8,00	D 100 x 22 x 7,0 x 5,5	24,10	25,24	30,29
UNC 7/16-14h	11,11	9,40	D 100 x 22 x 8,0 x 6,2	31,35	31,46	39,90
UNC 1/2-13h	12,70	10,75	D 110 x 24 x 9,0 x 7,0	28,68	31,77	39,95
UNC 9/16-12h	14,28	12,20	D 110 x 26 x 11,0 x 9,0	46,12	50,61	56,75
UNC 5/8-11h	15,87	13,50	D 110 x 27 x 12,0 x 9,0	44,77	49,30	65,06
UNC 3/4-10h	19,05	16,50	D 125 x 30 x 14,0 x 11,0	73,03	80,27	91,32
UNC 7/8-9h	22,22	19,50	D 140 x 32 x 18,0 x 14,5	96,08	105,56	137,94
UNC 1"-8h	25,40	22,25	D 160 x 36 x 18,0 x 14,5	126,95	138,69	156,16
UNC 1.1/8-7h	28,57	25,00	D 180 x 40 x 22,0 x 18,0	158,59		191,59
UNC 1.1/4-7h	31,75	28,00	D 180 x 40 x 22,0 x 18,0	185,91		245,10
UNC 1.3/8-6h	34,92	30,75	D 200 x 50 x 28,0 x 22,0	265,74		
UNC 1.1/2-6h	38,10	34,00	D 200 x 50 x 32,0 x 24,0	314,91		

MASCHI PER FILETTARE A MACCHINA HSSCo

UNF

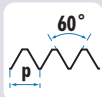

HSSCo
5%

TOL
2B

Vc
12 m/min

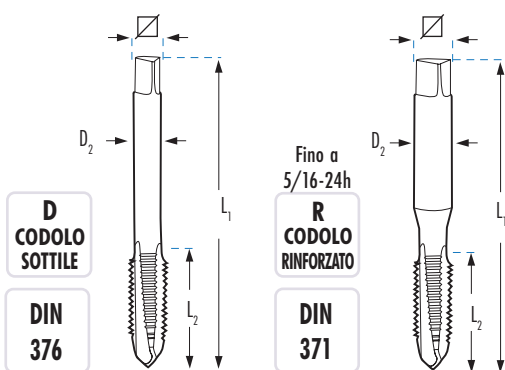

UNF n°	D1 mm	D2 mm	R	L1 x L2 x D2 x ∅ mm	M1R	M2R	M4R
					FORMA C	FORMA B	35°
					€	€	€
4-48h	2,84	2,35	R	56 x 11 x 3,5 x 2,7	16,42	17,88	22,62
5-44h	3,17	2,70	R	56 x 11 x 3,5 x 2,7	16,42	17,88	22,62
6-40h	3,50	2,95	R	56 x 12 x 4,0 x 3,0	14,88	17,82	22,65
8-36h	4,17	3,50	R	63 x 13 x 4,5 x 3,4	14,88	17,82	22,65
10-32h	4,83	4,10	R	70 x 15 x 6,0 x 4,9	14,88	17,82	22,65
12-28h	5,49	4,60	R	80 x 16 x 6,0 x 4,9	15,00	17,97	22,62
1/4-28h	6,35	5,50	R	80 x 17 x 7,0 x 5,5	16,68	17,88	22,56
5/16-24h	7,94	6,90	R	90 x 20 x 8,0 x 6,2	19,69	22,54	27,33

CODOLO SOTTILE				M1D	M2D	M4D	
UNF			D				
3/8-24h	9,52	8,50	D	90 x 16 x 7,0 x 5,5	21,84	25,24	31,35
7/16-20h	11,11	9,90	D	100 x 22 x 8,0 x 6,2	24,84	29,97	39,67
1/2-20h	12,70	11,50	D	100 x 22 x 9,0 x 7,0	24,99	30,09	40,04
9/16-18h	14,29	12,90	D	100 x 22 x 11,0 x 9,0	37,49	45,15	56,93
5/8-18h	15,87	14,50	D	100 x 22 x 12,0 x 9,0	37,63	45,28	63,61
3/4-16h	19,05	17,50	D	110 x 25 x 14,0 x 11,0	56,89	68,49	81,38
7/8-14h	22,22	20,40	D	125 x 25 x 18,0 x 14,5	71,53	86,14	124,46
1"-12h	25,40	23,25	D	140 x 28 x 18,0 x 14,5	87,03	109,75	136,00
UNS 1"-14h	25,40	23,60	D	140 x 28 x 18,0 x 14,5	95,93	112,85	146,49
UNF 1.1/8-12h	28,57	26,50	D	150 x 28 x 22,0 x 18,0	153,51		
UNF 1.1/4-12h	31,75	29,50	D	150 x 28 x 22,0 x 18,0	194,00		
UNF 1.1/2-12h	38,10	36,00	D	170 x 30 x 32,0 x 24,0	325,57		

MASCHI PER FILETTARE A MACCHINA HSSCo

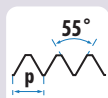
BSP
(GAS)HSSCo
5%TOL
ISO 228

INOX

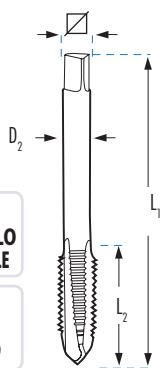
Vc
12 m/minVc
6 m/minD
CODOLO
SOTTILEDIN
5156

Icona	D1 mm	Ø	L1 x L2 x D2 x ∇ mm	M1D	M2D	M3D	M4D	M2DX	M4DX
				FORMA C €	FORMA B €	15° €	35° €	FORMA B €	35° €
G 1/8-28h.	9,728	8,80	D 90 x 16 x 7 x 5,5	29,55 *	31,87	34,27	35,85	46,20	51,89
G 1/4-19h.	13,157	11,80	D 100 x 22 x 11 x 9,0	38,24 *	42,11	49,20	51,01	56,84	64,21
G 3/8-19h.	16,662	15,25	D 100 x 22 x 12 x 9,0	46,94 *	48,70	58,77	61,46	67,42	81,55
G 1/2-14h.	20,955	19,00	D 125 x 25 x 16 x 12,0	62,02 *	68,24	74,13	75,93	98,66	113,68
G 5/8-14h.	22,911	21,00	D 125 x 25 x 18 x 14,5	77,29 *	76,46	92,31	90,41		
G 3/4-14h.	26,441	24,50	D 140 x 28 x 20 x 16,0	97,07	106,85	116,04	121,35	158,82	209,13
G 7/8-14h.	30,201	28,25	D 150 x 28 x 22 x 18,0	105,01	110,45	156,06	156,06		
G 1"-11h.	33,249	30,75	D 160 x 30 x 25 x 20,0	150,69	156,35	178,16	186,34		
G 1.1/8-11h.	37,897	35,50	D 170 x 30 x 28 x 22,0	207,63	226,47		275,75		
G 1.1/4-11h.	41,910	39,50	D 170 x 30 x 32 x 24,0	256,79	270,20		291,44		
G 1.3/8-11h.	44,323	42,00	D 180 x 32 x 36 x 29,0	322,94			436,98		
G 1.1/2-11h.	47,803	45,25	D 190 x 32 x 36 x 29,0	283,49	395,17		426,36		
G 1.3/4-11h.	53,746	51,25	D 190 x 32 x 40 x 32,0	511,90	493,31				
G 2"-11h.	59,614	57,00	D 220 x 36 x 45 x 35,0	652,86	667,67				

* Disponibili anche con filettatura sinistra al doppio del prezzo.

BSF

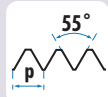
HSSCo
5%TOL
ISO 228Vc
12 m/minD
CODOLO
SOTTILEDIN
5156

Icona	D1 mm	Ø	L1 x L2 x D2 x ∇ mm	M1D
				FORMA C €
BSF 3/16-32h.	4,762	4,00	D 70 x 16 x 3,5 x 2,7	69,16
BSF 1/4-26h.	6,350	5,20	D 80 x 17 x 4,5 x 3,4	30,24
BSF 5/16-22h.	7,938	6,60	D 90 x 20 x 6,0 x 4,9	35,94
BSF 3/8-20h.	9,525	8,10	D 100 x 22 x 7,0 x 5,5	37,76
BSF 7/16-18h.	11,113	9,50	D 100 x 22 x 8,0 x 6,2	50,89
BSF 1/2-16h.	12,700	11,00	D 110 x 24 x 9,0 x 7,0	57,58
BSF 9/16-16h.	14,287	12,50	D 110 x 25 x 11,0 x 9,0	60,94
BSF 5/8-14h.	15,876	14,00	D 110 x 27 x 12,0 x 9,0	81,25
BSF 3/4-12h.	19,051	16,50	D 125 x 30 x 14,0 x 11,0	96,16
BSF 7/8-11h.	22,226	19,50	D 140 x 32 x 18,0 x 14,5	133,68
BSF 1"-10h.	25,400	22,50	D 160 x 36 x 18,0 x 14,5	155,38

MASCHI PER FILETTARE A MACCHINA HSSCo

BSW

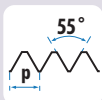

HSSCo
5%

TOL
Classe 2

Vc
12 m/min

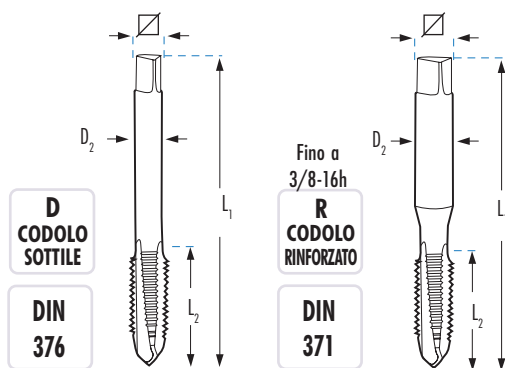

	D1 mm		L1 x L2 x D2 x ∇ mm	M1R	M2R	M3R	M4R
				FORMA C	FORMA B	15°	35°
				€	€	€	€
W 3/32-48h.	2,38	1,80	R 50 x 9 x 2,8 x 2,1	21,51	20,97		
W 1/8-40h.	3,17	2,55	R 56 x 11 x 3,5 x 2,7	17,02 *	18,80	20,43	21,37
W 5/32-32h.	3,97	3,10	R 63 x 13 x 4,5 x 3,4	17,02	18,80	20,43	21,37
W 3/16-24h.	4,76	3,60	R 70 x 15 x 6,0 x 4,9	21,13	22,40	20,43	21,37
W 7/32-24h.	5,56	4,40	R 80 x 16 x 6,0 x 4,9	25,84	27,33		
W 1/4-20h.	6,35	5,10	R 80 x 17 x 7,0 x 5,5	18,20	19,01	23,18	23,94
W 5/16-18h.	7,94	6,50	R 90 x 20 x 8,0 x 6,2	21,60	24,10	27,06	28,30
W 3/8-16h.	9,52	7,90	R 100 x 22 x 10,0 x 8,0	22,82	26,96	30,06	31,45

CODOLO SOTTILE				M1D	M2D	M3D	M4D
W 7/16-14h.	11,11	9,25	D 100 x 22 x 8,0 x 6,2	31,73	34,89	39,71	39,98
W 1/2-12h.	12,70	10,50	D 110 x 24 x 9,0 x 7,0	30,44	33,14	38,03	39,77
W 9/16-12h.	14,29	12,00	D 110 x 26 x 11,0 x 9,0	43,63	45,82	54,55	57,05
W 5/8-11h.	15,87	13,40	D 110 x 27 x 12,0 x 9,0	41,31	45,38	51,58	53,94
W 3/4-10h.	19,05	16,50	D 125 x 30 x 14,0 x 11,0	57,81	63,61	69,11	72,27
W 7/8-9h.	22,22	19,25	D 140 x 32 x 18,0 x 14,5	74,87	82,31	93,53	93,53
W 1"-8h.	25,40	21,75	D 160 x 36 x 18,0 x 14,5	94,09	103,44	117,39	122,78
W 1.1/8-7h.	28,57	24,75	D 180 x 40 x 22,0 x 18,0	127,61	134,18	205,24	
W 1.1/4-7h.	31,75	27,75	D 180 x 40 x 22,0 x 18,0	185,39	183,95		
W 1.3/8-6h.	34,92	30,50	D 200 x 50 x 28,0 x 22,0	304,71	320,18		
W 1.1/2-6h.	38,10	33,50	D 200 x 50 x 32,0 x 24,0	330,74	347,85		
W 1.5/8-5h.	41,27	46,50	D 220 x 65 x 32,0 x 24,0	461,65	485,56		
W 1.3/4-5h.	44,45	39,00	D 220 x 58 x 36,0 x 29,0	476,20	523,82		
W 1.7/8-4,5h.	47,62	42,00	D 250 x 75 x 36,0 x 29,0	552,13	580,72		
W 2"-4,5h.	50,80	44,50	D 250 x 65 x 40,0 x 32,0	681,52			

* Disponibili anche con filettatura sinistra al doppio del prezzo.

MASCHI PER FILETTARE A MACCHINA HSSCo

UNJC

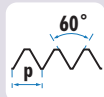
HSSCo
5%TOL
3B

UNJF

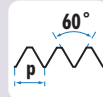
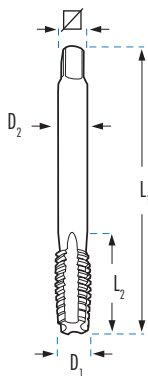
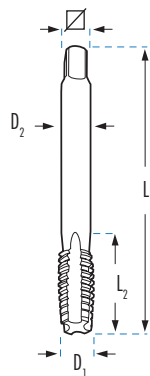
HSSCo
5%TOL
3BVc
12 m/minVc
12 m/min

MIR	FORMA C	€	L1 x L2 x D2 x ∇ mm	D1 mm	∇	D	R	MIR
UNJC n° 4-40h	2,84	2,25	R 56 x 11 x 3,5 x 2,7	42,71				
UNJC n° 5-40h	3,17	2,60	R 56 x 11 x 3,5 x 2,7	42,71				
UNJC n° 6-32h	3,50	2,75	R 56 x 12 x 4,0 x 3,0	42,71				
UNJC n° 8-32h	4,17	3,50	R 63 x 13 x 4,5 x 3,4	42,71				
UNJC n°10-24h	4,83	3,90	R 70 x 15 x 6,0 x 4,9	42,71				
UNJC n°12-24h	5,49	4,50	R 80 x 16 x 6,0 x 4,9	44,80				
UNJC 1/4-20h	6,35	5,10	R 80 x 17 x 7,0 x 5,5	39,86				
UNJC 5/16-18h	7,94	6,60	R 90 x 20 x 8,0 x 6,2	45,10				
UNJC 3/8-16h	9,52	8,00	R 100 x 22 x 8,0 x 6,2	51,41				

MIR	FORMA C	€	L1 x L2 x D2 x ∇ mm	D1 mm	∇	D	R	MIR
UNJF n° 4-48h	2,84	2,35	R 56 x 11 x 3,5 x 2,7	46,86				
UNJF n° 5-44h	3,17	2,70	R 56 x 11 x 3,5 x 2,7	46,86				
UNJF n° 6-40h	3,50	2,95	R 56 x 12 x 4,0 x 3,0	46,86				
UNJF n° 8-36h	4,17	3,50	R 63 x 13 x 4,5 x 3,4	46,86				
UNJF n°10-32h	4,83	4,10	R 70 x 15 x 6,0 x 4,9	46,86				
UNJF n°12-28h	5,49	4,60	R 80 x 16 x 6,0 x 4,9	46,86				
UNJF 1/4-28h	6,35	5,50	R 80 x 17 x 7,0 x 5,5	36,37				
UNJF 5/16-24h	7,94	6,90	R 90 x 20 x 8,0 x 6,2	40,68				
UNJF 3/8-24h	9,52	8,50	R 90 x 16 x 7,0 x 6,2	44,53				

CODOLO SOTTILE PASSI NORMALI				M1D
UNJC 7/16-14h	11,11	9,40	D 110 x 24 x 9,0 x 7,0	70,90
UNJC 1/2-13h	12,70	10,75	D 110 x 26 x 11,0 x 9,0	76,97
UNJC 9/16-12h	14,28	12,20	D 110 x 27 x 12,0 x 9,0	105,77
UNJC 5/8-11h	15,87	13,50	D 110 x 27 x 12,0 x 9,0	115,55
UNJC 3/4-10h	19,05	16,50	D 125 x 30 x 14,0 x 11,0	136,04
UNJC 7/8-9h	22,22	19,50	D 140 x 32 x 18,0 x 14,5	179,00
UNJC 1"-8h	25,40	22,25	D 160 x 36 x 18,0 x 14,5	236,51

CODOLO SOTTILE PASSI NORMALI				M1D
UNJF 7/16-20h	11,11	9,90	D 100 x 22 x 8,0 x 6,2	61,16
UNJF 1/2-20h	12,70	11,50	D 100 x 22 x 9,0 x 7,0	65,13
UNJF 9/16-18h	14,29	12,90	D 100 x 22 x 11,0 x 9,0	80,02
UNJF 5/8-18h	15,87	14,50	D 100 x 22 x 12,0 x 9,0	90,09
UNJF 3/4-16h	19,05	17,50	D 110 x 25 x 14,0 x 11,0	115,25
UNJF 7/8-14h	22,22	20,40	D 125 x 25 x 18,0 x 14,5	144,93
UNJF 1"-12h	25,40	23,25	D 140 x 28 x 18,0 x 14,5	161,60

MASCHI PER FILETTARE A MACCHINA HSSCo

Maschi e Filere

Rosa

BSPB **DIN 2999** **55°** **HSSCo** **5%** **DIN** **374** **FORMA** **C**

BSPT **BS21 ISO7/1** **55°** **HSSCo** **5%** **DIN** **5156** **FORMA** **C**

FILETTATURA CILINDRICA INGLESE PER TUBI

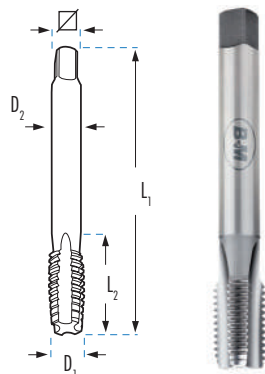

FILETTATURA CONICA INGLESE PER TUBI

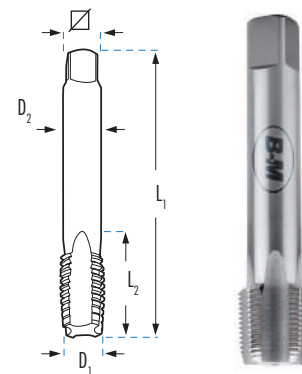

		D1 mm	L1 x L2 x D2 x mm	M1D	€
Rp	1/16-28h.	7,72	D 90 x 16 x 6 x 4,9		
Rp	1/8-28h.	9,73	D 90 x 16 x 7 x 5,5		51,43
Rp	1/4-19h.	13,16	D 100 x 22 x 11 x 9,0		71,04
Rp	3/8-19h.	16,66	D 100 x 22 x 12 x 9,0		85,06
Rp	1/2-14h.	20,95	D 125 x 25 x 16 x 12,0		107,49
Rp	3/4-14h.	26,44	D 140 x 28 x 20 x 16,0		168,33
Rp	1"-11h.	33,25	D 160 x 30 x 25 x 20,0		261,18
Rp	1.1/4-11h.	41,91	D 170 x 30 x 32 x 24,0		
Rp	1.1/2-11h.	46,80	D 190 x 32 x 36 x 29,0		
Rp	2"-11h.	59,61	D 220 x 36 x 45 x 35,0		

		D1 mm	θ	L1 x L2 x D2 x mm	M1D	€
Rc	1/16-28h.	7,72		D 90 x 14 x 6 x 4		
Rc	1/8-28h.	9,73	8,30	D 90 x 15 x 7 x 5		48,97
Rc	1/4-19h.	13,16	11,00	D 100 x 19 x 11 x 9		66,72
Rc	3/8-19h.	16,66	14,50	D 100 x 21 x 12 x 9		82,41
Rc	1/2-14h.	20,95	18,10	D 125 x 26 x 16 x 12		114,52
Rc	5/8-14h.	22,91	21,00	D 140 x 36 x 18 x 19		235,73
Rc	3/4-14h.	26,44	23,50	D 140 x 28 x 20 x 16		158,53
Rc	7/8-14h.	30,20	28,25	D 160 x 36 x 22 x 18		411,84
Rc	1"-11h.	33,25	29,60	D 160 x 33 x 25 x 20		294,41

NPS (M) **ANSI B 1.20.1** **60°** **HSSCo** **5%** **DIN** **374** **FORMA** **C**

NPT **ANSI B 1.20.1** **60°** **HSSCo** **5%** **DIN** **374** **FORMA** **C**

FILETTATURA CILINDRICA AMERICANA PER TUBI

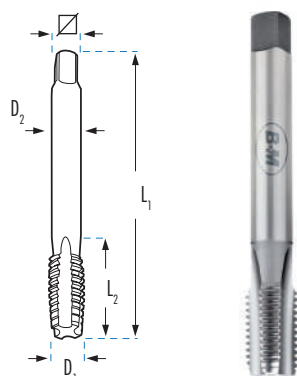

FILETTATURA CONICA AMERICANA PER TUBI

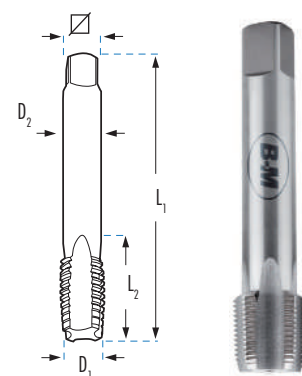

		D1 mm	θ	L1 x L2 x D2 x mm	M1D	€
NPS	1/8-27h.	10,20	8,90	D 90 x 16 x 7 x 5,5		137,57
NPS	1/4-18h.	13,60	11,70	D 100 x 22 x 11 x 9,0		196,88
NPS	3/8-18h.	17,00	15,00	D 100 x 22 x 12 x 9,0		269,98
NPS	1/2-14h.	21,20	18,60	D 125 x 25 x 16 x 12,0		370,21
NPS	3/4-14h.	26,55	24,00	D 140 x 28 x 20 x 16,0		547,29
NPS	1"-11,5 h.	33,20	30,00	D 160 x 30 x 25 x 20,0		707,73
NPS	1.1/4-11,5h.	41,60		D 170 x 30 x 32 x 24,0		
NPS	1.1/2-11,5h.	47,68		D 190 x 32 x 36 x 29,0		
NPS	2"-11,5h.	59,71		D 220 x 36 x 45 x 35,0		

		D1 mm	θ	L1 x L2 x D2 x mm	M1D	€
NPT	1/16-27h.	7,89	6,2	D 90 x 14 x 6 x 5		44,39
NPT	1/8-27h.	10,24	8,5	D 90 x 15 x 8 x 6		46,43
NPT	1/4-18h.	13,62	11,0	D 100 x 19 x 11 x 9		62,28
NPT	3/8-18h.	17,05	14,5	D 100 x 21 x 12 x 9		75,51
NPT	1/2-14h.	21,22	17,8	D 125 x 26 x 16 x 12		104,11
NPT	3/4-14h.	26,57	23,0	D 140 x 28 x 20 x 16		161,33
NPT	1"-11,5h.	33,23	29,0	D 160 x 33 x 25 x 20		209,66
NPT	1.1/4-11,5h.	41,98	37,5	D 170 x 36 x 32 x 24		275,78
NPT	1.1/2-11,5h.	48,05	44,0	D 190 x 37 x 36 x 29		450,79
NPT	2"-11,5h.	60,09	56,0	D 220 x 41 x 45 x 35		707,11

MASCHI PER FILETTARE A MACCHINA HSSCo

NPSF

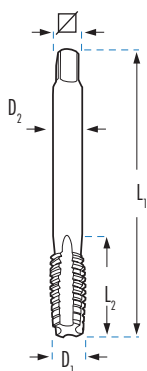
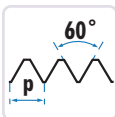
HSSCo
5%DIN
374FORMA
CFILETTATURA PER TUBI
AMERICANA CILINDRICA

NPTF

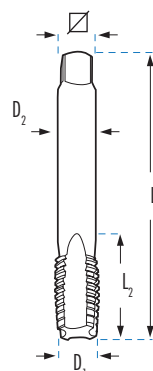
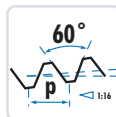
HSSCo
5%DIN
374FORMA
CFILETTATURA PER TUBI
AMERICANA CONICA A TENUTA STAGNA

								M1D	
		D1 mm	\emptyset	L1 x L2 x D2 x ∇ mm					€
NPSF	1/8-27h.	10,05	8,75	D 90 x 16 x 7 x 5,5					165,92
NPSF	1/4-18h.	13,33	11,30	D 100 x 22 x 11 x 9,0					228,71
NPSF	3/8-18h.	16,78	14,70	D 100 x 22 x 12 x 9,0					325,36
NPSF	1/2-14h.	20,87	18,20	D 125 x 25 x 16 x 12,0					405,73
NPSF	3/4-14h.	26,23	23,50	D 140 x 28 x 20 x 16,0					664,04
NPSF	1"-11,5h.	32,81	29,50	D 160 x 30 x 25 x 20,0					

								M1D	
		D1 mm	\emptyset	L1 x L2 x D2 x ∇ mm					€
NPTF	1/16-27h.	7,87	6,20	D 90 x 14 x 12,0 x 6					
NPTF	1/8-27h.	10,22	8,50	D 90 x 15 x 12,0 x 7					105,77
NPTF	1/4-18h.	13,58	11,00	D 100 x 21 x 17,5 x 11					148,37
NPTF	3/8-18h.	17,02	14,50	D 110 x 21 x 17,6 x 12					190,62
NPTF	1/2-14h.	21,21	17,80	D 140 x 27 x 22,8 x 16					248,14
NPTF	3/4-14h.	26,56	23,00	D 140 x 27 x 23,0 x 20					384,41

MF

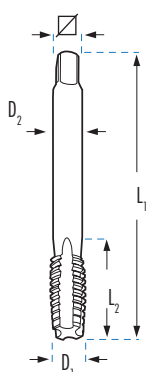
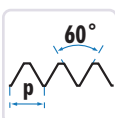
HSSCo
5%TOL
6HFORMA
CDIN
374FILETTATURA METRICA FINE PER TUBI DI
CONDUZIONE ELETTRICA
EN 60423

PG

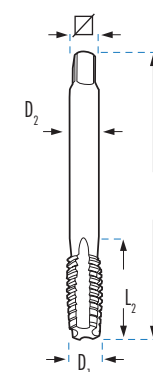
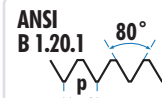
HSSCo
5%DIN
40430FORMA
CFILETTATURA PER TUBI
DI CONDUZIONE
ELETTRICA

								M1D	
		D1 mm	\emptyset	L1 x L2 x D2 x ∇ mm					€
MF	12 x 1,50	12	10,5	D 100 x 22 x 9 x 7,0					26,44
MF	16 x 1,50	16	14,5	D 100 x 22 x 12 x 9,0					37,24
MF	20 x 1,50	20	18,5	D 125 x 25 x 16 x 12,0					55,83
MF	25 x 1,50	25	23,5	D 140 x 28 x 18 x 14,5					121,43
MF	32 x 1,50	32	30,5	D 150 x 28 x 22 x 18,0					151,42
MF	40 x 1,50	40	38,5	D 170 x 30 x 32 x 24,0					255,01
MF	50 x 1,50	50	48,5	D 190 x 32 x 36 x 29,0					397,03
MF	63 x 1,50	63	61,5	D 275 x 36 x 50 x 39,0					

								M1D	
		D1 mm	\emptyset	L1 x L2 x D2 x ∇ mm					€
PG	7 - 20h.	12,5	11,50	D 100 x 22 x 9 x 7,0					49,19
PG	9 - 18h.	15,2	14,00	D 100 x 22 x 12 x 9,0					68,11
PG	11 - 18h.	18,6	17,25	D 110 x 25 x 14 x 11,0					88,65
PG	13,5 - 18h.	20,4	19,00	D 125 x 25 x 16 x 12,0					99,54
PG	16 - 18h.	22,5	21,25	D 125 x 25 x 18 x 14,5					117,15
PG	21 - 16h.	28,3	27,00	D 150 x 28 x 22 x 18,0					185,99
PG	29 - 16h.	37,0	35,50	D 170 x 30 x 28 x 22,0					314,39
PG	36 - 16h.	47,0	45,50	D 190 x 32 x 36 x 29,0					510,60
PG	42 - 16h.	54,0	52,50	D 190 x 32 x 40 x 32,0					810,94
PG	48 - 16h.	59,3	58,00	D 220 x 36 x 45 x 35,0					988,59

MASCHI PER FILETTARE A MACCHINA HSSCo

UNx8 HSSCo 5% DIN 374 FORMA C TOL 2B

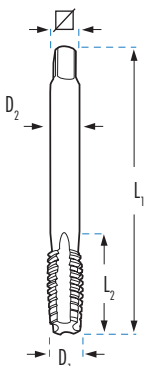
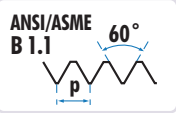

UNEF HSSCo 5% DIN 374 TOL 2B

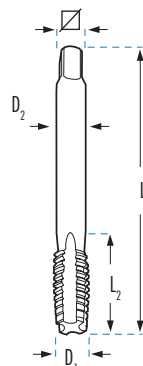
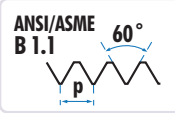

Icona	Ø	D2 mm	L1 x L2 x mm	M1D
				FORMA C
				€
UN 1" 1/8-8h.	25,40	22	180 x 45 x 18	307,69
UN 1" 1/4-8h.	28,50	22	180 x 48 x 18	396,95
UN 1" 3/8-8h.	31,75	28	200 x 56 x 22	450,29
UN 1" 1/2-8h.	35,00	32	200 x 58 x 22	537,46
UN 1" 5/8-8h.	38,10	32	200 x 65 x 24	628,71
UN 1" 3/4-8h.	41,25	36	200 x 50 x 29	765,89
UN 1" 7/8-8h.	44,45	36	225 x 53 x 29	856,95
UN 2"-8h.	47,63	40	225 x 50 x 32	902,69

Icona	Ø	D2 mm	L1 x L2 x mm	M2D	M4D
				FORMA B	35°
				€	€
UNEF 1/4-32h.	5,55	7,0	R 82 x 16 x 5,4	101,20	113,72
UNEF 5/16-32h.	7,15	8,4	R 85 x 21 x 6,1	111,49	125,27
UNEF 3/8-32h.	8,70	7,0	D 95 x 22 x 5,4	111,56	125,35
UNEF 7/16-28h.	10,20	8,0	D 100 x 22 x 6,2	148,06	166,37
UNEF 1/2-28h.	11,80	9,0	D 100 x 22 x 7,0	155,97	175,23
UNEF 9/16-24h.	13,20	12,0	D 100 x 24 x 9,0	195,39	219,56
UNEF 5/8-24h.	14,80	12,0	D 100 x 24 x 9,0	222,34	249,83
UNEF 3/4-20h.	17,80	14,0	D 110 x 27 x 11,0	289,18	324,94
UNEF 7/8-20h.	20,95	18,0	D 125 x 26 x 14,5	310,85	333,05
UNEF 1"-20h.	24,20	18,0	D 140 x 28 x 14,5	475,70	534,48

MASCHI PER FILETTARE A MACCHINA HSSCo A SINISTRA

M MF HSSCo 5% FORMA C TOL 6H

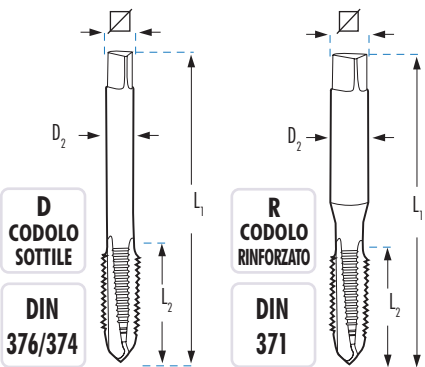
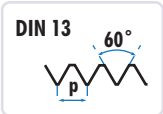

Icona	Ø	L1 x L2 x D2 x mm	M1R1
			FORMA C
			€
M 3x0,50	2,50	R 56 x 11 x 3,5 x 2,7	23,90
M 4x0,70	3,30	R 63 x 13 x 4,5 x 3,4	26,67
M 5x0,80	4,20	R 70 x 16 x 6,0 x 4,9	24,34
M 6x1,00	5,00	R 80 x 17 x 6,0 x 4,9	26,86
M 7x1,00	6,00	R 80 x 17 x 7,0 x 5,5	35,93
M 8x1,25	6,80	R 90 x 20 x 8,0 x 6,2	31,29
M 10x1,50	8,50	R 100 x 22 x 10,0 x 8,0	34,82

CODOLO SOTTILE			M1D1
			€
M 12x1,50	10,50	D 100 x 22 x 9,0 x 7,0	52,88
M 12x1,75	10,20	D 110 x 24 x 9,0 x 7,0	38,14
M 14x1,50	12,50	D 100 x 22 x 11,0 x 9,0	63,00
M 14x2,00	12,00	D 110 x 26 x 11,0 x 9,0	62,56
M 16x1,50	14,50	D 100 x 22 x 12,0 x 9,0	74,49
M 16x2,00	14,00	D 110 x 27 x 12,0 x 9,0	73,61
M 18x1,50	16,50	D 110 x 25 x 14,0 x 11,0	98,57
M 18x2,50	15,50	D 125 x 30 x 14,0 x 11,0	99,92
M 20x1,50	18,50	D 125 x 25 x 16,0 x 12,0	111,66
M 20x2,50	17,50	D 140 x 32 x 16,0 x 12,0	112,73
M 22x2,50	19,50	D 140 x 32 x 18,0 x 14,5	136,44
M 24x2,00	22,00	D 140 x 28 x 18,0 x 14,5	198,91
M 24x3,00	21,00	D 160 x 34 x 18,0 x 14,5	163,34
M 27x3,00	24,00	D 160 x 36 x 20,0 x 16,0	203,91
M 30x2,00	28,00	D 150 x 28 x 22,0 x 18,0	289,63
M 30x3,50	26,50	D 180 x 40 x 22,0 x 18,0	261,28
M 33x3,50	29,50	D 180 x 40 x 25,0 x 20,0	313,95
M 36x4,00	32,00	D 200 x 50 x 28,0 x 22,0	374,39

Consultare altre misure disponibili su richiesta.

MASCHI A MACCHINA METRICA NORMA ISO 529

M
MF

DIN 13

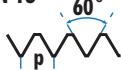

60°

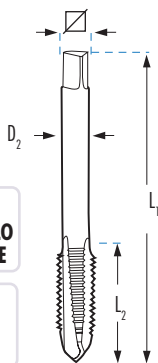
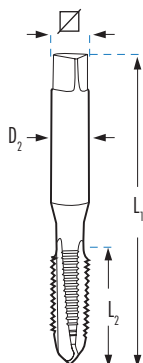
HSSCo
5%ISO
529TOL
6HD
CODOLO
SOTTILE
ISO
529R
CODOLO
RINFORZATO
ISO
529

		L1 x L2 x D2 x ∇ mm	M1RISO	M2RISO	M4RISO	M5RISO
			FORMA C	FORMA B	35°	DENTI ALTERNATI Al
			€	€	€	€
M 3x0,50	2,50	R 48 x 11 x 3,15 x 2,50	8,88	9,26	11,15	12,02
M 4x0,70	3,30	R 53 x 13 x 4,00 x 3,15	8,88	9,26	11,15	12,02
M 5x0,80	4,20	R 58 x 16 x 5,00 x 4,00	8,88	9,26	11,15	12,02
M 6x1,00	5,00	R 66 x 19 x 6,30 x 5,00	8,88	9,26	11,39	12,02
M 7x1,00	6,00	R 66 x 19 x 7,10 x 5,60		12,63	15,47	
M 8x1,00	7,00	R 69 x 19 x 8,00 x 6,30		16,34	16,16	
M 8x1,25	6,75	R 72 x 22 x 8,00 x 6,30	11,87	12,37	12,78	13,14
M 9x1,25	7,75	R 76 x 20 x 10,00 x 8,00		17,66	19,37	
M 10x1,00	9,00	R 76 x 20 x 10,00 x 8,00		18,75	20,49	
M 10x1,25	8,80	R 76 x 20 x 10,00 x 8,00		22,41	23,14	
M 10x1,50	8,50	R 80 x 24 x 10,00 x 8,00	15,09	15,72	16,46	16,57
CODOLO SOTTILE			M1DISO	M2DISO	M4DISO	M5DISO
M 12x1,00	11,00	D 84 x 24 x 9,00 x 7,10		27,91	28,33	
M 12x1,25	10,75	D 84 x 24 x 9,00 x 7,10		28,19	28,13	
M 12x1,50	10,50	D 89 x 29 x 9,00 x 7,10		25,17	26,09	
M 12x1,75	10,20	D 89 x 29 x 9,00 x 7,10	17,56	20,20	21,40	24,80
M 14x1,00	13,00	D 90 x 25 x 11,20 x 9,00		35,83	43,72	
M 14x1,25	12,80	D 90 x 25 x 11,20 x 9,00		31,41	39,48	
M 14x1,50	12,50	D 95 x 30 x 12,50 x 9,00		24,94	31,12	
M 14x2,00	12,00	D 95 x 30 x 11,20 x 9,00	23,18	24,15	29,24	
M 16x1,00	15,00	D 95 x 25 x 12,50 x 10,00		49,05	50,65	
M 16x1,25	14,75	D 102 x 32 x 12,50 x 10,00		49,49	50,85	
M 16x1,50	14,50	D 102 x 32 x 14,00 x 10,00		34,70	38,98	
M 16x2,00	14,00	D 102 x 32 x 12,50 x 10,00	28,79	29,99	33,92	
M 18x1,50	16,50	D 104 x 29 x 14,00 x 11,20		45,86	55,66	
M 18x2,50	15,50	D 112 x 37 x 14,00 x 11,20	43,35	45,15	56,45	
M 20x1,50	18,50	D 104 x 29 x 14,00 x 11,20		52,15	59,87	
M 20x2,50	17,50	D 112 x 37 x 14,00 x 11,20	48,45	50,47	59,52	
M 22x2,50	19,50	D 118 x 38 x 16,00 x 12,50	56,03	58,36	72,95	
M 24x3,00	21,00	D 130 x 45 x 18,00 x 14,00	63,29	65,93	82,40	
M 27x3,00	24,00	D 135 x 45 x 20,00 x 16,00	77,94	81,19	101,48	
M 30x3,50	26,50	D 138 x 48 x 20,00 x 16,00	115,79	120,62	142,24	

MASCHI A MACCHINA CORTI DIN 352

**M
MF**

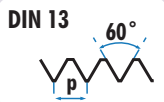

HSS

**HSSCo
5%**

**DIN
352**

**TOL
6H**

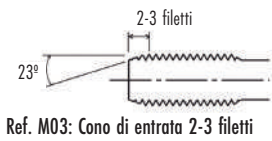

Ref. M03: Cono di entrata 2-3 filetti

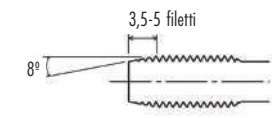

Ref. M02AT: Cono di entrata 3,5-5 filetti

**D
CODOLO
SOTTILE**

**DIN
352**

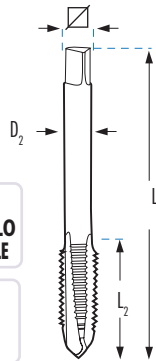

Icona	Ø	L1 x L2 x D2 x mm	M03	M02AT	M03X	M02DIN	M04DIN
			HSS €	ALTEZZA FINITA HSS €	INOX HSSCo €	FORMA B HSS €	35° HSS €
M 3x0,50	2,50	D 40 x 11 x 3,50 x 2,70	5,05	6,70	11,43	10,19	12,26
M 4x0,70	3,30	D 45 x 13 x 4,50 x 3,40	5,05	6,69	11,43	10,19	12,26
M 5x0,80	4,20	D 50 x 16 x 6,00 x 4,90	5,64	7,47	11,59	10,19	12,26
M 6x1,00	5,00	D 50 x 19 x 6,00 x 4,90	5,70	7,56	11,57	10,19	12,54
M 7x1,00	6,00	D 50 x 19 x 6,00 x 4,90	7,51				
M 8x1,00	7,00	D 56 x 18 x 6,00 x 4,90	10,63				
M 8x1,25	6,75	D 56 x 22 x 6,00 x 4,90	6,23	8,26	13,28	13,59	15,84
M 9x1,25	7,75	D 63 x 18 x 7,00 x 5,50	8,46				
M 10x1,00	9,00	D 63 x 18 x 7,00 x 5,50	12,50				
M 10x1,25	8,80	D 70 x 24 x 7,00 x 5,50	11,64				
M 10x1,50	8,50	D 70 x 24 x 7,00 x 5,50	8,02	10,64	17,76	17,28	19,31
M 12x1,00	11,00	D 70 x 20 x 9,00 x 7,00	20,49				
M 12x1,25	10,75	D 70 x 20 x 9,00 x 7,00	20,42				
M 12x1,50	10,50	D 70 x 20 x 9,00 x 7,00	18,84				
M 12x1,75	10,20	D 75 x 29 x 9,00 x 7,00	10,11	13,40	23,18	20,98	25,62
M 14x1,00	13,00	D 70 x 20 x 11,00 x 9,00	31,82				
M 14x1,25	12,80	D 70 x 20 x 11,00 x 9,00	23,74				
M 14x1,50	12,50	D 70 x 20 x 11,00 x 9,00	20,34				
M 14x2,00	12,00	D 80 x 30 x 11,00 x 9,00	13,02	17,25	29,24	26,57	32,16
M 16x1,00	15,00	D 70 x 20 x 12,00 x 9,00	34,70				
M 16x1,25	14,75	D 70 x 20 x 12,00 x 9,00	34,91				
M 16x1,50	14,50	D 70 x 20 x 12,00 x 9,00	25,00				
M 16x2,00	14,00	D 80 x 32 x 12,00 x 9,00	15,61		35,67	32,99	37,31
M 18x1,50	16,50	D 80 x 22 x 14,00 x 11,00	25,51				
M 18x2,50	15,50	D 95 x 40 x 14,00 x 11,00	20,74		46,72	48,84	55,89
M 20x1,50	18,50	D 80 x 22 x 16,00 x 12,00	27,63				
M 20x2,50	17,50	D 95 x 40 x 16,00 x 12,00	22,89		52,59	55,52	58,93
M 22x2,50	19,50	D 100 x 40 x 18,00 x 14,50	32,02			64,19	72,23
M 24x3,00	21,00	D 110 x 50 x 18,00 x 14,50	37,10			72,52	81,59
M 27x3,00	24,00	D 110 x 50 x 20,00 x 16,00	48,29			94,49	103,74
M 30x3,50	26,50	D 125 x 50 x 22,00 x 18,00	61,19			129,43	132,94

MASCHI A MACCHINA E FILIERE SERIE *Plus* E *Super Plus*

Maschi e Filiere

Rosa

Plus

DIN 13



60°

TOL
6H

PER LAVORAZIONI DI ALTA PRODUZIONE
FABBRICATI IN ACCIAIO SINTERIZZATO

DIN
22568

TOL
6g



		<i>Plus</i>		<i>Plus TiN</i>		<i>Plus LUBE</i>		<i>Super Plus ALTiN</i>				<i>C5P</i>	
		M2RP	M4RP	M2RT	M4RT	M2RHL	M4RHL	M2RSP	M4RSP				
QUALITÀ		★★	★★	★★★	★★★	★★★★	★★★★	★★★	★★★				
MATERIALE		HSS PM	HSS PM	HSSCo 5%	HSSCo 5%	HSS PM	HSS PM	HSS V3	HSS V3			HSS	
FINITURA		BRILLANTE	BRILLANTE	TiN	TiN	HARD LUBE	HARD LUBE	ALTiN	ALTiN			BRILLANTE	
ANGOLO DELL'ELICA		FORMA B	FORMA B 35°	FORMA B	FORMA B 35°	FORMA B	FORMA B 35°	FORMA B	FORMA B 41°				
L1 x L2 x D2 x Ø		mm	mm	mm	mm	mm	mm	mm	mm	mm	mm	mm	mm
		€	€	€	€	€	€	€	€	€	€	€	€
M 3x0,50	2,50	R	56 x 11 x 3,5 x 2,7	14,31	17,68	20,78	23,37	23,88	25,86	44,51	46,58	25 x 9	26,85
M 4x0,70	3,30	R	63 x 13 x 4,5 x 3,4	14,62	17,68	21,91	24,41	24,23	26,21	44,51	46,58	25 x 9	26,85
M 5x0,80	4,20	R	70 x 16 x 6,0 x 4,9	14,62	16,96	21,91	23,92	24,23	26,21	47,00	48,29	25 x 9	26,85
M 6x1,00	5,00	R	80 x 17 x 6,0 x 4,9	16,09	18,61	24,30	26,31	26,63	27,74	47,00	48,29	25 x 9	26,85
M 8x1,00	7,00	D	90 x 20 x 6,0 x 4,9	22,94	27,24	31,74	35,31	37,46	41,70			25 x 9	36,07
M 8x1,25	6,80	R	90 x 20 x 8,0 x 6,2	18,84	21,63	28,14	30,88	31,42	35,29	59,66	63,58	25 x 9	28,06
M 10x1,00	9,00	D	90 x 16 x 7,0 x 5,5	25,60	32,11	37,07	42,57	43,75	51,70			30 x 10	44,09
M 10x1,50	8,50	R	100 x 22 x 10,0 x 8,0	22,14	25,19	33,60	36,65	38,94	43,92	71,10	75,84	30 x 10	40,04
CODOLO SOTTILE		M2DP	M4DP	M2DT	M4DT	M2DHL	M4DHL	M2DSP	M4DSP				
M 12x1,50	10,50	D	100 x 22 x 9,0 x 7,0	30,37	36,70	42,43	47,80	48,97	56,18			38 x 10	49,88
M 12x1,75	10,20	D	110 x 24 x 9,0 x 7,0	28,54	33,88	41,63	46,52	43,49	52,68	89,46	97,05	38 x 14	44,03
M 14x1,50	12,50	D	100 x 22 x 11,0 x 9,0	35,96	45,11	49,00	56,20	57,60	66,05			38 x 10	52,14
M 14x2,00	12,00	D	110 x 26 x 11,0 x 9,0	35,69	41,38	50,89	55,95	58,21	63,98	91,35	122,99	38 x 14	44,89
M 16x1,50	14,50	D	100 x 22 x 12,0 x 9,0	45,00	55,48	58,87	67,34	64,46	66,38			45 x 14	71,61
M 16x2,00	14,00	D	110 x 27 x 12,0 x 9,0	41,99	50,00	58,12	65,46	66,44	73,45	124,69	132,63	45 x 18	60,29
M 18x2,50	15,50	D	125 x 30 x 14,0 x 11,0	59,49	67,23	73,63	80,33	88,57	99,74	185,06	200,22	45 x 18	60,29
M 20x2,50	17,50	D	140 x 32 x 16,0 x 12,0	64,30	71,67	83,92	90,42	98,64	112,30	197,23	208,48	45 x 18	60,29
M 22x2,50	19,50	D	140 x 32 x 18,0 x 14,5	77,79	88,43	98,42	107,40	115,67	126,22			55 x 22	90,48
M 24x3,00	21,00	D	160 x 34 x 18,0 x 14,5	92,48	105,87	110,91	122,86	130,34	144,38			55 x 22	90,48

MASCHI A MACCHINA PER LAVORAZIONI SPECIALI HSS-PM

INOX

M

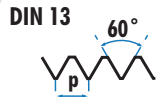

TOL
6H

Vc
6 m/min

Vc
10 m/min

Vc
12 m/min

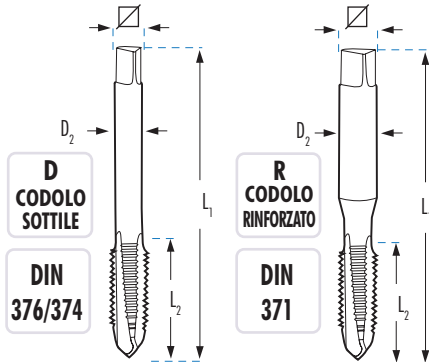

QUALITÀ	M2RX		M4RX		M2RXT		M4RXT		M2RXHL		M4RXHL	
	★★		★★		★★★		★★★		★★★★		★★★★	
MATERIALE	HSS PM		HSS PM		HSSCo 5%		HSSCo 5%		HSS PM		HSS PM	
FINITURA	OX		OX		TIN		TIN		HARD LUBE		HARD LUBE	
ANGOLO DELL'ELICA	FORMA B		35°		FORMA B		35°		FORMA B		35°	
	$L_1 \times L_2 \times D_2 \times \varnothing$ mm											
	€		€		€		€		€		€	
M 3x0,50	2,50	R	56 x 11 x 3,5 x 2,7	17,72	20,57	20,72	24,36	27,94	32,87			
M 4x0,70	3,30	R	63 x 13 x 4,5 x 3,4	17,96	20,57	21,75	25,26	29,36	34,40			
M 5x0,80	4,20	R	70 x 16 x 6,0 x 4,9	18,62	21,99	21,75	25,48	29,36	34,40			
M 6x1,00	5,00	R	80 x 17 x 6,0 x 4,9	18,72	22,68	23,81	26,80	32,14	36,16			
M 8x1,00	7,00	D	90 x 20 x 6,0 x 4,9	39,04	42,78							
M 8x1,25	6,80	R	90 x 20 x 8,0 x 6,2	21,95	26,16	26,59	30,57	35,89	41,24			
M 10x1,00	9,00	D	90 x 16 x 7,0 x 5,5	40,24	42,96							
M 10x1,50	8,50	R	100 x 22 x 10,0 x 8,0	25,49	30,66	32,49	36,23	43,85	48,89			
CODOLO SOTTILE			M2DX	M4DX	M2DXT	M4DXT	M2DXHL	M4DXHL				
M 12x1,00	11,00	D	100 x 22 x 9,0 x 7,0	45,63	52,35							
M 12x1,50	10,50	D	100 x 22 x 9,0 x 7,0	46,32	54,77							
M 12x1,75	10,20	D	110 x 24 x 9,0 x 7,0	32,35	46,07	41,73	52,20	58,78	68,84			
M 14x2,00	12,00	D	110 x 26 x 11,0 x 9,0	42,42	60,55	55,45	65,29	78,12	86,51			
M 16x2,00	14,00	D	110 x 27 x 12,0 x 9,0	46,55	66,39	61,36	83,61	86,99	104,64			
M 18x2,50	15,50	D	125 x 30 x 14,0 x 11,0	66,69	94,45	94,36	117,02	139,59	148,88			
M 20x2,50	17,50	D	140 x 32 x 16,0 x 12,0	68,80	111,28	108,82	120,40	148,38	157,19			
M 22x2,50	19,50	D	140 x 32 x 18,0 x 14,5	130,49	137,88	148,21	176,54					
M 24x3,00	21,00	D	160 x 34 x 18,0 x 14,5	137,19	157,47	151,10	180,56					
M 27x3,00	24,00	D	160 x 36 x 20,0 x 16,0	179,71	206,27							
M 30x3,50	26,50	D	180 x 40 x 22,0 x 18,0	229,81	263,78							



- Lubrificazione: **CUT MAGIC XTHICK**
- Si raccomanda l'applicazione dell'olio da taglio CUT MAGIC XTHICK per ottimizzare il processo di filettatura in Inox, Inconel, Titanio, Duplex, ecc...

Ref. ACXT00250

MASCHI *Super Plus* PER FILETTATURA DI LEGHE REFRATTIVE



Maschi e Filere

Rosa

M **DIN 13** **60°** **TOL 6H** **INOX DUPLEX** **Ni** **INC** **Ti**

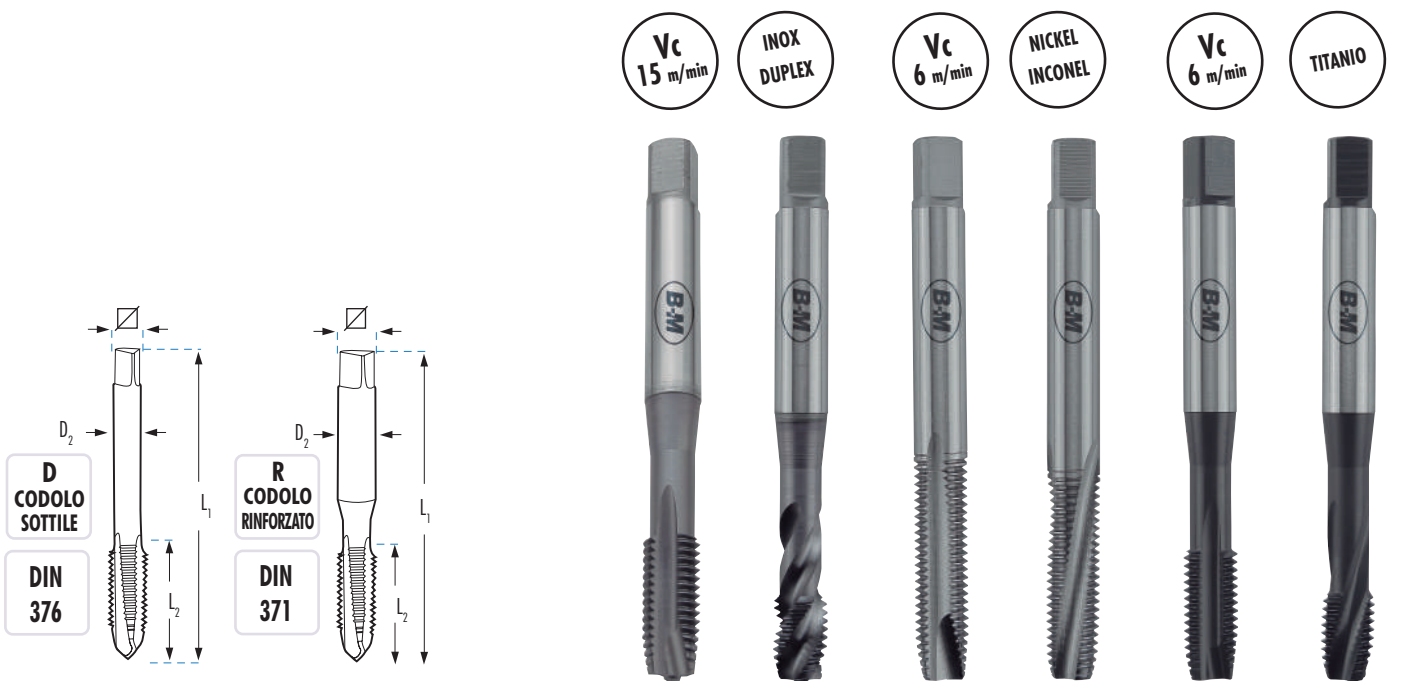
PARTICOLARMENTE RACCOMANDATO IN APPLICAZIONI AERONAUTICHE



			M2RDU	M4RDU	M2RNI	M3RNI	M2RTIT	M3RTIT
QUALITÀ			★★★★	★★★★	★★★★	★★★★	★★★★	★★★★
MATERIALE			HSS V3	HSS V3	HSS PM	HSS PM	HSS PM	HSS PM
FINITURA			TiCN	TiCN	BRILLANTE	BRILLANTE	OX	OX
ANGOLO DELL'ELICA			FORMA B	41°	FORMA B	15°	FORMA B	15°
		L1 x L2 x D2 x \square mm	€	€	€	€	€	€
M 3x0,50	2,50	R 56 x 11 x 3,5 x 2,7	45,12	46,22	83,85	85,68	62,24	68,70
M 4x0,70	3,30	R 63 x 13 x 4,5 x 3,4	45,12	46,52	85,68	87,99	64,20	68,70
M 5x0,80	4,20	R 70 x 16 x 6,0 x 4,9	46,63	47,54	88,69	90,78	65,81	73,19
M 6x1,00	5,00	R 80 x 17 x 6,0 x 4,9	47,93	48,96	89,40	91,92	65,81	74,20
M 8x1,25	6,80	R 90 x 20 x 8,0 x 6,2	66,94	69,78	101,02	103,71	76,04	85,68
M 10x1,50	8,50	R 100 x 22 x 10,0 x 8,0	86,75	89,01	120,04	123,70	94,19	103,23
CODOLO SOTTILE			M2DDU	M4DDU	M2DNI	M3DNI	M2DTIT	M3DTIT
M 12x1,75	10,20	D 110 x 24 x 9,0 x 7,0	117,30	126,65	154,38	170,71	118,20	128,28
M 14x2,00	12,00	D 110 x 26 x 11,0 x 9,0						
M 16x2,00	14,00	D 110 x 27 x 12,0 x 9,0	172,48	184,43				
M 18x2,50	15,50	D 125 x 30 x 14,0 x 11,0						
M 20x2,50	17,50	D 140 x 32 x 16,0 x 12,0	255,40	275,88				
M 22x2,50	19,50	D 140 x 32 x 18,0 x 14,5						
M 24x3,00	21,00	D 160 x 34 x 18,0 x 14,5	345,93	351,84				
M 27x3,00	24,00	D 160 x 36 x 20,0 x 16,0	444,42	465,86				
M 30x3,50	26,50	D 180 x 40 x 22,0 x 18,0	524,87	549,21				

MASCHI A MACCHINA PER ACCIAIO STRUTTURALI EXTRA DOLCE < DE 450 N/mm²

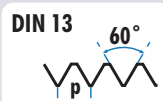

HSSCo
5%

OX

TOL
6H

APPLICAZIONI



ST52

Al

Geometria di taglio specifica per materiali morbidi, non genera sovradimensionamento e si adatta perfettamente a questo tipo di materiali in cui i maschi convenzionali possono causare allargamenti durante la generazione del filo.

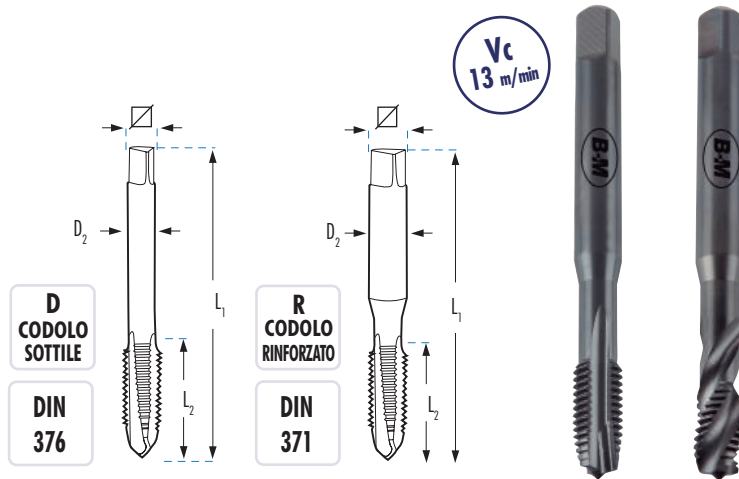

		$L_1 \times L_2 \times D_2 \times \square$ mm	M2RSS	M4RSS
			FORMA B	35°
			€	€
M 3 x 0,50	2,50	R 56 x 11 x 3,5 x 2,7	14,90	19,60
M 4 x 0,70	3,30	R 63 x 13 x 4,5 x 3,4	15,73	19,62
M 5 x 0,80	4,20	R 70 x 16 x 6,0 x 4,9	15,83	18,81
M 6 x 1,00	5,00	R 80 x 17 x 6,0 x 4,9	16,77	20,65
M 8 x 1,25	6,80	R 90 x 20 x 8,0 x 6,2	19,39	23,90
M 10 x 1,50	8,50	R 100 x 22 x 10,0 x 8,0	23,88	28,30
CODOLO SOTTILE			M2DSS	M4DSS
M 12 x 1,75	10,20	D 110 x 24 x 9,0 x 7,0	27,09	32,80
M 14 x 2,00	12,00	D 110 x 26 x 11,0 x 9,0	38,68	45,51
M 16 x 2,00	14,00	D 110 x 27 x 12,0 x 9,0	43,16	52,52
M 18 x 2,50	15,50	D 125 x 30 x 14,0 x 11,0	61,48	74,00
M 20 x 2,50	17,50	D 140 x 32 x 16,0 x 12,0	71,97	78,99
M 22 x 2,50	19,50	D 140 x 32 x 18,0 x 14,5	86,38	96,29
M 24 x 3,00	21,00	D 160 x 34 x 18,0 x 14,5	101,77	117,02
M 27 x 3,00	24,00	D 160 x 36 x 20,0 x 16,0	128,71	143,99
M 30 x 3,50	26,50	D 180 x 40 x 22,0 x 18,0	165,36	184,53

MASCHI A MACCHINA PER LAVORAZIONI SPECIALI HSS-V3

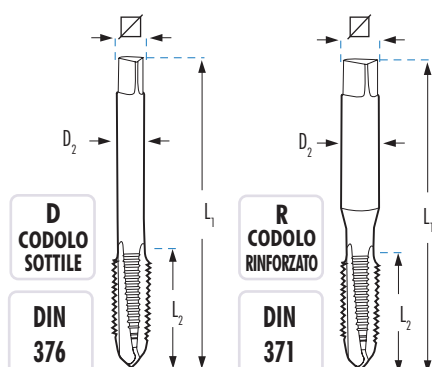
HSS
V3TOL
6HMATERIALI
DURIVc
7 m/minVc
9 m/min

				M2RMD	M4RMD	M2RMDTX	M4RMDTX
QUALITÀ				★★★	★★★	★★★★	★★★★
MATERIALE				HSS V3	HSS V3	HSS V3	HSS V3
FINITURA				OX	OX	TINALOX	TINALOX
ANGOLO DELL'ELICA				FORMA B	35°	FORMA B	35°
			L1 x L2 x D2 x \square mm	€	€	€	€
M 3x0,50	2,50	R	56 x 11 x 3,5 x 2,7	18,35	21,08	26,17	30,77
M 4x0,70	3,30	R	63 x 13 x 4,5 x 3,4	19,07	21,08	27,49	32,21
M 5x0,80	4,20	R	70 x 16 x 6,0 x 4,9	19,07	20,97	27,49	32,21
M 6x1,00	5,00	R	80 x 17 x 6,0 x 4,9	20,90	23,06	30,10	33,87
M 8x1,25	6,80	R	90 x 20 x 8,0 x 6,2	23,55	25,78	33,61	38,64
M 10x1,50	8,50	R	100 x 22 x 10,0 x 8,0	27,14	29,97	42,53	47,44
		CODOLO SOTTILE		M2DMD	M4DMD	M2DMDTX	M4DMDTX
M 12x1,75	10,20	D	110 x 24 x 9,0 x 7,0	38,69	42,29	56,64	66,30
M 14x2,00	12,00	D	110 x 26 x 11,0 x 9,0	48,11	55,89	80,61	88,48
M 16x2,00	14,00	D	110 x 27 x 12,0 x 9,0	56,76	67,61	89,79	107,04
M 18x2,50	15,50	D	125 x 30 x 14,0 x 11,0	80,24	96,20	132,00	149,49
M 20x2,50	17,50	D	140 x 32 x 16,0 x 12,0	86,71	101,58	142,66	157,79

MASCHI A MACCHINA PER MATERIALI TEMPRATI (HARDOX 450/500)

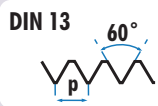
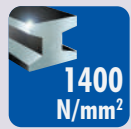

TOL
6H

HSSE

HSS
PM

MD

MATERIALI
MOLTO
DURI

48
HRc

48-62
HRc



MD

Vc
5 m/min

48
HRc

48-62
HRc

Materiali molto duri

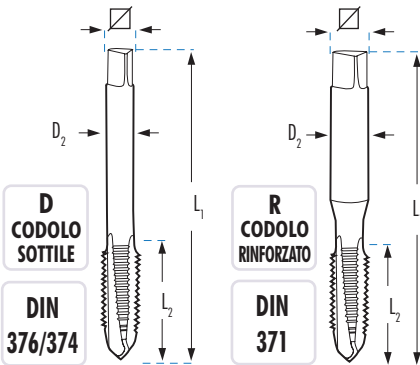

MATERIALE	M2RC	M3RC	M2HRC	M4HRC	M1RCM		M1RHMC			
	HSSE	HSSE	HSS PM	HSS PM	HSS PM		MD			
FINITURA	TiAIN	TiAIN	TINALOX	TINALOX	TiCN		TiCN			
FORMA	FORMA B	FORMA B 15°	FORMA B	FORMA B 35°	FORMA C		FORMA C			
Ø	€	€	€	€	Ø	€	Ø	€		
M 3 x 0,50	2,50	R 56 x 11 x 3,5 x 2,7	29,52	31,41	41,71	46,70	2,60	47,28	2,60	122,41
M 4 x 0,70	3,30	R 63 x 13 x 4,5 x 3,4	29,58	33,44	43,31	48,52	3,40	41,59	3,40	122,41
M 5 x 0,80	4,20	R 70 x 16 x 6,0 x 4,9	29,85	32,68	43,73	48,97	4,30	46,47	4,30	122,41
M 6 x 1,00	5,00	R 80 x 17 x 6,0 x 4,9	32,28	36,18	45,61	51,08	5,10	59,50	5,10	153,01
M 8 x 1,25	6,80	R 90 x 20 x 8,0 x 6,2	37,29	42,55	56,70	63,50	6,90	66,00	6,90	172,21
M 10 x 1,50	8,50	R 100 x 22 x 10,0 x 8,0	44,64	52,71	67,86	71,25	8,60	85,56	8,60	264,23
CODOLO SOTTILE			M2DC	M3DC	M2HDC	M4HDC	M1RCM		M1DHMC	
M 12 x 1,75	10,20	D 110 x 24 x 9,0 x 7,0	66,74	79,22	103,59	112,92	10,40	113,20 *	10,40	413,84
M 14 x 2,00	12,00	D 110 x 26 x 11,0 x 9,0	90,11	105,40	122,84	133,90	12,10	143,12 *	12,10	532,91
M 16 x 2,00	14,00	D 110 x 27 x 12,0 x 9,0	101,68	121,07	136,59	148,89	14,10	153,09 *	16,10	695,86
M 18 x 2,50	15,50	D 125 x 30 x 14,0 x 11,0	128,75	140,20	144,48	157,48			15,75	850,13
M 20 x 2,50	17,50	D 140 x 32 x 16,0 x 12,0	155,93	162,29	199,67	217,64			17,75	1.344,76
M 22 x 2,50	19,50	D 140 x 32 x 18,0 x 14,5	220,88	230,33						
M 24 x 3,00	21,00	D 160 x 34 x 18,0 x 14,5	226,13	236,63	269,93	294,22				
M 27 x 3,00	24,00	D 160 x 36 x 20,0 x 16,0	241,76	254,48						
M 30 x 3,50	26,50	D 180 x 40 x 22,0 x 18,0	253,31	268,13						

* Codolo Rinforzato: M12 - Ø 12 x 9
M14 - Ø 14 x 11
M16 - Ø 16 x 12



- Lubrificazione: **CUT MAGIC XTHICK**
- Si raccomanda di filettare il pezzo sulla stessa attrezzatura utilizzata per la foratura precedente e nella stessa posizione, per garantire co-assialità tra il maschio e il preforo.

Ref. ACXT00250

HRc	Vc (m/min)
48 Hrc	8 m/min
56 Hrc	6 m/min
62 Hrc	3 m/min

MASCHI A MACCHINA QUALSIASI TERRENO

QUALSIASI
TERRENOHSSCo
5%

TiN

TOL
6H

APPLICAZIONI

1200
N/mm²

Al

GHISA

Ti

INOX

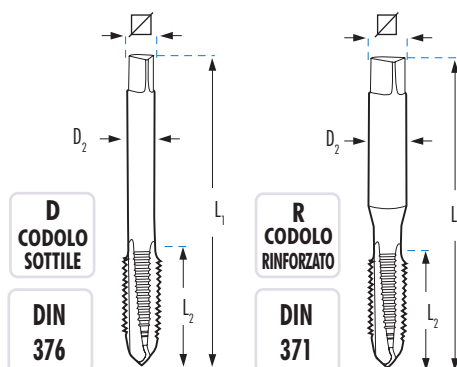
Vc
13 m/min

			L1 x L2 x D2 x ∇ mm	M2RD	M4RD
				FORMA B	
				€	€
M 3 x 0,50	2,50	R	56 x 11 x 3,5 x 2,7	21,91	26,79
M 4 x 0,70	3,30	R	63 x 13 x 4,5 x 3,4	23,22	26,79
M 5 x 0,80	4,20	R	70 x 16 x 6,0 x 4,9	26,91	30,60
M 6 x 1,00	5,00	R	80 x 17 x 6,0 x 4,9	27,83	31,75
M 8 x 1,25	6,80	R	90 x 20 x 8,0 x 6,2	32,61	36,24
M 10 x 1,50	8,50	R	100 x 22 x 10,0 x 8,0	37,63	42,90
CODOLO SOTTILE				M2DD	M4DD
M 12 x 1,75	10,20	D	110 x 24 x 9,0 x 7,0	47,42	56,44
M 14 x 2,00	12,00	D	110 x 26 x 11,0 x 9,0	61,92	68,05
M 16 x 2,00	14,00	D	110 x 27 x 12,0 x 9,0	69,38	75,10
M 18 x 2,50	15,50	D	125 x 30 x 14,0 x 11,0	94,67	111,18
M 20 x 2,50	17,50	D	140 x 32 x 16,0 x 12,0	110,43	114,59

MASCHI A MACCHINA PER LAVORAZIONI SPECIALI HSSCo

Maschi e Filiere
Rosa

Al

GHISA

OTTONE

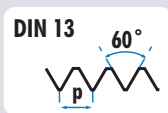

HSSCo
5%

MD

TOL
6H

Vc
18 m/min

Vc
11 m/min

Vc
21 m/min

Vc
16 m/min

Vc
19 m/min

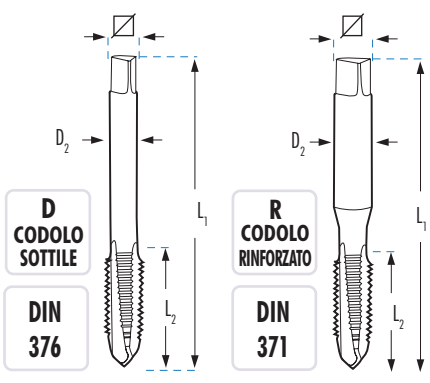

			M5R	M6R	M1RFM	MHM1R	M1RL	M1RLCRN
APPLICAZIONE			Al	Al	GHISA	GHISA	OTTONE	OTTONE
MATERIALE			HSSCo 5%	HSSCo 5%	HSSCo 5%	MD	HSSCo 5%	HSSCo 5%
FINITURA			BRILLANTE	BRILLANTE	OX	BRILLANTE	BRILLANTE	CrN
FORMA			DENTI ALTERNATI	2 CANALI	FORMA C	FORMA C	FORMA C	FORMA C
		L1 x L2 x D2 x \square mm	€	€	€	€	€	€
M 3x0,50	2,50	R 56 x 11 x 3,5 x 2,7	17,28	19,96	14,84	82,76	17,61	19,99
M 4x0,70	3,30	R 63 x 13 x 4,5 x 3,4	17,26	19,96	15,35	82,76	18,70	22,05
M 5x0,80	4,20	R 70 x 16 x 6,0 x 4,9	18,02	20,36	15,35	82,76	18,70	22,11
M 6x1,00	5,00	R 80 x 17 x 6,0 x 4,9	17,97	22,02	17,42	94,38	20,48	24,16
M 8x1,25	6,80	R 90 x 20 x 8,0 x 6,2	21,82	26,39	19,52	105,40	23,35	29,38
M 10x1,50	8,50	R 100 x 22 x 10,0 x 8,0	25,92	31,22	22,31	132,08	28,09	35,75
CODOLO SOTTILE			M5D	M6D	M1DFM	MHM1D	M1DL	M1DLCRN
M 12x1,75	10,20	D 110 x 24 x 9,0 x 7,0	33,19	40,36	28,60	187,77	33,40	44,00
M 14x2,00	12,00	D 110 x 26 x 11,0 x 9,0	42,87	51,09	47,00	292,55	41,00	53,64
M 16x2,00	14,00	D 110 x 27 x 12,0 x 9,0	47,64	66,87	55,31	348,04	47,17	59,98
M 18x2,50	15,50	D 125 x 30 x 14,0 x 11,0			77,37	426,63	61,89	75,97
M 20x2,50	17,50	D 140 x 32 x 16,0 x 12,0			77,66	516,62	69,46	84,58



- Lubrificazione: **CUT MAGIC ALUMINIO**
- Si raccomanda l'applicazione dell'olio da taglio CUT MAGIC ALUMINIO per ottimizzare il processo di filettatura in alluminio e le sue ghise.

Ref. ACAL00250

MASCHI PER FILETTARE A MACCHINA PER LAMINAZIONE



HSSCo
5%

HSSCo
8%

TOL
6HX

APPLICAZIONI



Al

GHISA



INOX

Plus

R
CODOLO
RINFORZATO

DIN
2174

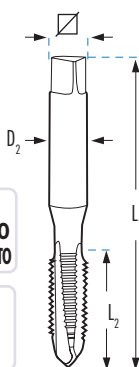

				M07R	M07RT	M07RCR	M07RCCR	M09RCCR	M07RXTCR
		APPLICAZIONE		LAMINAZIONE	LAMINAZIONE	LAMINAZIONE	LAMINAZIONE	LAMINAZIONE	LAMINAZIONE
		MATERIALE		HSSCo 5%	HSSCo 5%	HSSCo 5%	HSSCo 5%	HSSCo 8%	HSSCo 5%
		FINITURA		OX	TiN	OX	TiCN	TiCN	TiN
		FORMA							
			L1 x L2 x D2 x \square mm	€	€	€	€	€	€
M 3x0,50	2,75	R	56 x 11 x 3,5 x 2,7	26,22	36,87	33,96	51,72	117,35	87,52
M 3,5x0,60	3,20	R	56 x 11 x 3,5 x 2,7	27,56	39,15	37,20	54,73		
M 4x0,70	3,65	R	63 x 13 x 4,5 x 3,4	28,70	38,46	33,61	53,94	118,83	87,52
M 5x0,80	4,60	R	70 x 16 x 6,0 x 4,9	28,70	38,46	35,99	53,94	120,41	94,45
M 6x1,00	5,50	R	80 x 17 x 6,0 x 4,9	29,32	40,64	36,63	57,00	122,33	94,45
M 8x1,25	7,40	R	90 x 20 x 8,0 x 6,2	35,32	53,63	42,72	75,24	135,69	113,03
M 10x1,50	9,30	R	100 x 22 x 10,0 x 8,0	41,46	60,14	50,36	82,82	162,02	138,00
CODOLO SOTTILE				M07D	M07DT	M07DCR	M07DCCR	M09DCCR	M07DXTCR
M 12x1,75	11,20	D	110 x 24 x 9,0 x 7,0	50,88	75,74	59,34	105,64	191,78	179,71
M 14x2,00	13,05	D	110 x 26 x 11,0 x 9,0	91,75	124,22	98,97	169,37	238,67	258,51
M 16x2,00	15,05	D	110 x 27 x 12,0 x 9,0	107,72	139,90	116,18	198,74	328,27	262,99
M 18x2,50	16,80	D	125 x 30 x 14,0 x 11,0	131,01	161,08	141,31	211,83	388,95	
M 20x2,50	18,80	D	140 x 32 x 16,0 x 12,0	172,63	243,85	186,20	347,39	430,62	

MASCHI A MACCHINA HSSCo A TOLLERANZA SPECIALE E SOVRAMISURA

Maschi e Filiere

Rosa

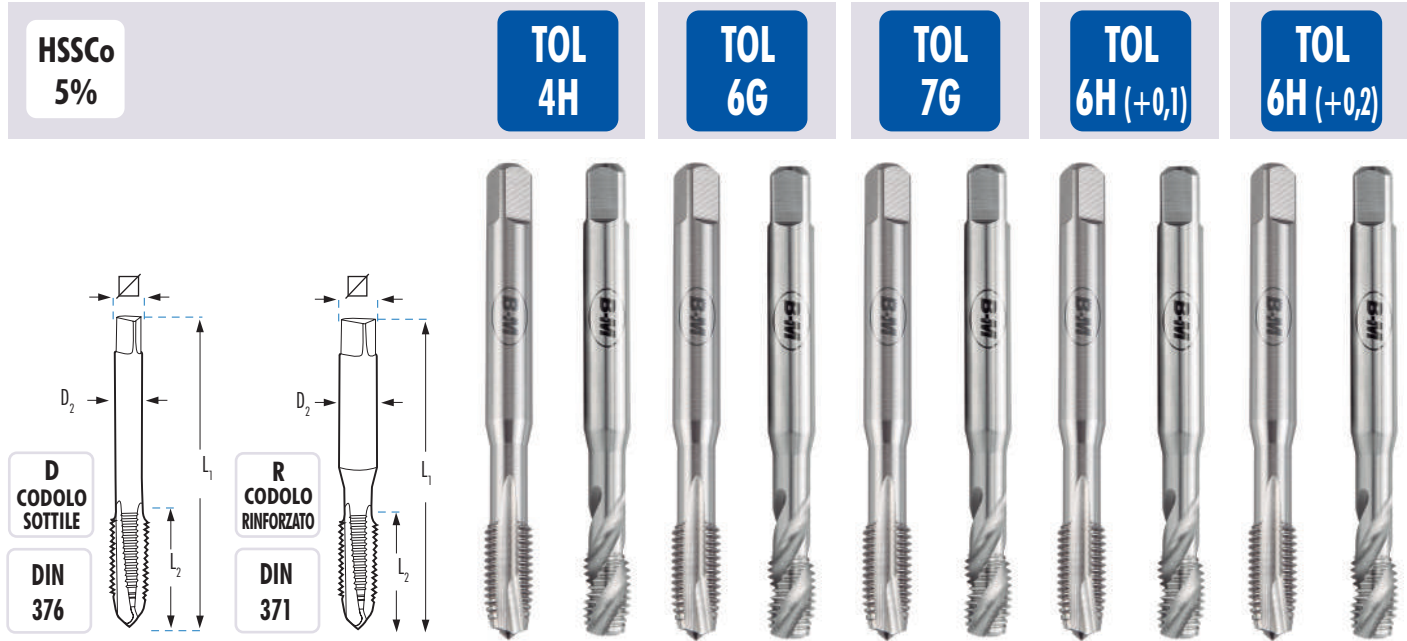

		M2R4H	M4R4H	M2R6G	M4R6G	M2R7G	M4R7G	M2R+0,1	M4R+0,1	M2R+0,2	M4R+0,2		
		TOL 4H	TOL 4H	TOL 6G	TOL 6G	TOL 7G	TOL 7G	TOL 6H (+0,1)	TOL 6H (+0,1)	TOL 6H (+0,2)	TOL 6H (+0,2)		
		HSSCo 5%	HSSCo 5%	HSSCo 5%	HSSCo 5%	HSSCo 5%	HSSCo 5%	HSSCo 5%	HSSCo 5%	HSSCo 5%	HSSCo 5%		
		BRILLANTE	BRILLANTE	BRILLANTE	BRILLANTE	BRILLANTE	BRILLANTE	BRILLANTE	BRILLANTE	BRILLANTE	BRILLANTE		
		FORMA B	FORMA B 35°	FORMA B	FORMA B 35°	FORMA B	FORMA B 35°	FORMA B	FORMA B 35°	FORMA B	FORMA B 35°		
		€	€	€	€	€	€	€	€	€	€		
M	3x0,50	2,50	R 56 x 11 x 3,5 x 2,7	20,51	25,37	14,48	17,66	17,42	21,54	17,19	21,81	26,50	32,81
M	4x0,70	3,30	R 63 x 13 x 4,5 x 3,4	20,98	25,37	14,48	17,66	17,82	21,54	17,19	21,81	27,11	28,95
M	5x0,80	4,20	R 70 x 16 x 6,0 x 4,9	20,98	24,31	15,23	18,43	17,82	20,63	17,19	20,90	27,11	31,43
M	6x1,00	5,00	R 80 x 17 x 6,0 x 4,9	23,06	26,68	15,17	18,55	19,59	22,64	17,25	22,92	29,80	34,48
M	8x1,00	7,00	D 90 x 20 x 6,0 x 4,9			35,83	39,64						
M	8x1,25	6,75	R 90 x 20 x 8,0 x 6,2	25,82	30,45	19,29	22,87	21,91	25,84	21,15	26,17	29,47	39,36
M	10x1,00	9,00	D 90 x 16 x 7,0 x 5,5			42,30	49,23						
M	10x1,50	8,50	R 100 x 22 x 10,0 x 8,0	31,74	36,13	22,87	26,18	26,95	34,08	26,01	31,03	36,24	41,20
		CODOLO SOTTILE		M2D4H	M4D4H	M2D6G	M4D6G	M2D7G	M4D7G	M2D+0,1	M4D+0,1	M2D+0,2	M4D+0,2
M	12x1,50	10,50	D 100 x 22 x 9,0 x 7,0			74,85	88,74						
M	12x1,75	10,20	D 110 x 24 x 9,0 x 7,0	40,95	48,62	26,72	28,97	32,83	38,98	32,10	49,12	46,68	55,45
M	14x2,00	12,00	D 110 x 26 x 11,0 x 9,0			38,93	41,70			69,54	82,91	86,29	100,02
M	16x2,00	14,00	D 110 x 27 x 12,0 x 9,0			43,48	44,25			81,80	100,19	89,60	106,68
M	18x2,50	15,50	D 125 x 30 x 14,0 x 11,0			60,49	64,88			119,16	134,91	143,78	151,40
M	20x2,50	17,50	D 140 x 32 x 16,0 x 12,0			74,52	85,48			128,77	143,57	155,35	163,13

4H.-Per filettature molto precise. Regolazione più esatta.
 6G.- Per filettature con rivestimenti. Spessore tra 20 – 40 μ
 7G.-Per filettature con rivestimenti. Spessore tra 20 – 50 μ
 6H. (+0,1)- Per ottenere filettature con sovrasure o per compensare deformazioni da trattamenti termici.
 6H. (+0,2)- Per ottenere filettature con sovrasure o per compensare deformazioni da trattamenti termici.

MASCHI A MACCHINA EXTRA LUNGI HSSCo

FORMA
BHSSCo
5%

BRILLANTE

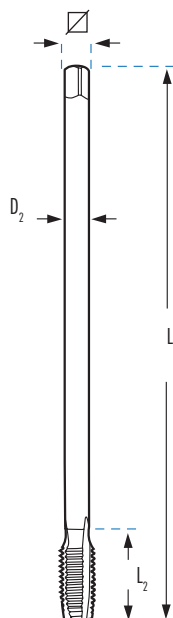
TOL
6HR
CODOLO
RINFORZATODIN
371D
CODOLO
SOTTILEDIN
376

				M2L	
				FORMA B	€
			L1 x L2 x D2 x mm		
M2LM03X0,50	M 3x0,50	2,50	R 100 x 10 x 3,5 x 2,7	18,62	
M2LM04X0,70	M 4x0,70	3,30	R 120 x 12 x 4,5 x 3,4	19,04	
M2LM05X0,80	M 5x0,80	4,20	R 140 x 14 x 6,0 x 4,9	22,40	
M2LM06X1,00-120	M 6x1,00	5,00	R 120 x 16 x 6,0 x 4,9	21,01	
M2LM06X1,00	M 6x1,00	5,00	R 160 x 16 x 6,0 x 4,9	22,43	
M2LM07X1,00	M 7x1,00	6,00	R 160 x 17 x 7,0 x 5,5	27,20	
M2LM08X1,25-150	M 8x1,25	6,80	R 150 x 18 x 8,0 x 6,2	25,41	
M2LM08X1,25	M 8x1,25	6,80	R 180 x 18 x 8,0 x 6,2	27,33	
				M2L-D	
					€
			D L1 x L2 x D2 x mm		
M2LM06X1,00D	M 6x1,00	5,00	D 160 x 16 x 4,5 x 3,4	24,89	
M2LM08X1,25D	M 8x1,25	6,80	D 180 x 18 x 6,2 x 5,0	29,19	
M2LM10X1,50-150	M 10x1,50	8,50	D 150 x 20 x 7,0 x 5,5	29,51	
M2LM10X1,50	M 10x1,50	8,50	D 200 x 20 x 7,0 x 5,5	31,45	
M2LM12X1,75-150	M 12x1,75	10,20	D 150 x 22 x 8,5 x 6,5	33,51	
M2LM12X1,75	M 12x1,75	10,20	D 220 x 22 x 8,5 x 6,5	35,60	
M2LM14X2,00	M 14x2,00	12,00	D 220 x 25 x 10,5 x 8,0	66,02	
M2LM16X2,00	M 16x2,00	14,00	D 220 x 28 x 12,5 x 10,0	77,68	
M2LM18X2,50	M 18x2,50	15,50	D 250 x 32 x 14,0 x 11,0	141,32	
M2LM20X2,50	M 20x2,50	17,50	D 250 x 32 x 16,0 x 12,0	152,76	
M2LM22X2,50	M 22x2,50	19,50	D 250 x 35 x 18,0 x 14,5	247,13	
M2LM24X3,00	M 24x3,00	21,00	D 250 x 38 x 18,0 x 14,5	311,18	

HSSCo
5%

BRILLANTE

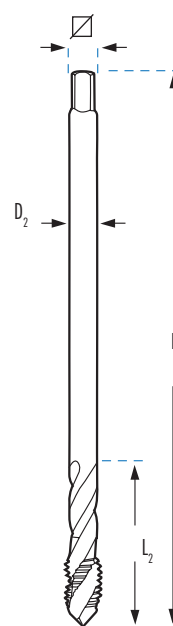
TOL
6HR
CODOLO
RINFORZATODIN
371D
CODOLO
SOTTILEDIN
376

				M4L	
				35°	€
			L1 x L2 x D2 x mm		
M4LM03X0,50	M 3x0,50	2,50	R 100 x 10 x 3,5 x 2,7	22,07	
M4LM04X0,70	M 4x0,70	3,30	R 120 x 12 x 4,5 x 3,4	23,04	
M4LM05X0,80	M 5x0,80	4,20	R 140 x 14 x 6,0 x 4,9	25,29	
M4LM06X1,00-120	M 6x1,00	5,00	R 120 x 16 x 6,0 x 4,9	25,01	
M4LM06X1,00	M 6x1,00	5,00	R 160 x 16 x 6,0 x 4,9	26,74	
M4LM07X1,00	M 7x1,00	6,00	R 160 x 17 x 7,0 x 5,5	31,50	
M4LM08X1,25-150	M 8x1,25	6,80	R 150 x 18 x 8,0 x 6,2	29,01	
M4LM08X1,25	M 8x1,25	6,80	R 180 x 18 x 8,0 x 6,2	31,27	
				M4L-D	
					€
			D L1 x L2 x D2 x mm		
M4LM06X1,00D	M 6x1,00	5,00	D 160 x 16 x 4,5 x 3,4	28,82	
M4LM08X1,25D	M 8x1,25	6,80	D 180 x 18 x 6,2 x 5,0	33,73	
M4LM10X1,50-150	M 10x1,50	8,50	D 150 x 20 x 7,0 x 5,5	35,85	
M4LM10X1,50	M 10x1,50	8,50	D 200 x 20 x 7,0 x 5,5	38,01	
M4LM12X1,75-150	M 12x1,75	10,20	D 150 x 22 x 8,5 x 6,5	37,11	
M4LM12X1,75	M 12x1,75	10,20	D 220 x 22 x 8,5 x 6,5	39,51	
M4LM14X2,00	M 14x2,00	12,00	D 220 x 25 x 10,5 x 8,0	73,99	
M4LM16X2,00	M 16x2,00	14,00	D 220 x 28 x 12,5 x 10,0	107,23	
M4LM18X2,50	M 18x2,50	15,50	D 250 x 32 x 14,0 x 11,0	160,03	
M4LM20X2,50	M 20x2,50	17,50	D 250 x 32 x 16,0 x 12,0	170,30	
M4LM22X2,50	M 22x2,50	19,50	D 250 x 35 x 18,0 x 14,5	278,63	
M4LM24X3,00	M 24x3,00	21,00	D 250 x 38 x 18,0 x 14,5	326,81	

MASCHIO A MACCHINA PER DADI FILETTATURA METRICA DIN 357



HSSCo
5%

BRILLANTE

TOL
6H

DIN
357

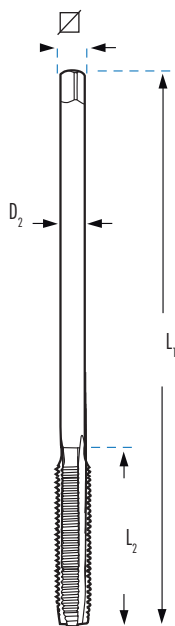

			MTU	
		$L1 \times L2 \times D2 \times \nabla$ mm	FORMA A	€
M	3x0,50**	2,50 D 70 x 22 x 2,2		24,00
M	4x0,70	3,30 D 90 x 25 x 2,8 x 2,1		24,00
M	5x0,80	4,20 D 100 x 28 x 3,5 x 2,7		24,00
M	6x1,00	5,00 D 110 x 32 x 4,5 x 3,4		24,00
M	8x1,25	6,80 D 125 x 40 x 6,0 x 4,9		29,27
M	10x1,50	8,50 D 140 x 45 x 7,0 x 5,5		31,50
M	12x1,75	10,20 D 180 x 50 x 9,0 x 7,0		51,73
M	14x2,00	12,00 D 200 x 56 x 11,0 x 9,0		60,26
M	16x2,00	14,00 D 200 x 63 x 12,0 x 9,0		74,62
M	18x2,50	15,50 D 220 x 63 x 14,0 x 11,0		100,39
M	20x2,50	17,50 D 250 x 70 x 16,0 x 12,0		127,26*
M	22x2,50	19,50 D 280 x 80 x 18,0 x 14,5		156,14*
M	24x3,00	21,00 D 280 x 80 x 18,0 x 14,5		212,43*

** Codolo cilindrico

*Fino ad esaurimento scorte

MASCHIO A MACCHINA PER FILETTATURA TRAPEZOIDALE HSS

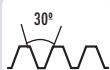

HSS

BRILLANTE



DIN
103

TOL
7H

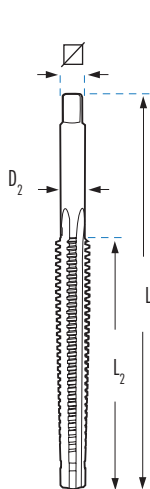

			MRTM	
		$L1 \times L2 \times D2 \times \nabla$ mm	€	
Tr	14 x 3	11,25 160 x 105 x 10,5 x 8,0	399,63	
Tr	16 x 4	12,25 205 x 110 x 11,5 x 9,0	434,12	
Tr	18 x 4	14,25 215 x 120 x 13,0 x 10,0	444,94	
Tr	20 x 4	16,25 230 x 130 x 15,0 x 12,0	466,17	
Tr	22 x 5	17,25 270 x 165 x 16,0 x 12,0	605,21	
Tr	24 x 5	19,25 280 x 165 x 18,0 x 14,5	696,01	
Tr	26 x 5	21,25 290 x 170 x 20,0 x 16,0	720,14	
Tr	28 x 5	23,25 300 x 180 x 22,0 x 18,0	804,59	
Tr	30 x 6	24,25 345 x 200 x 23,0 x 18,0	951,69	

PUNTA-MASCHIO HSSCo

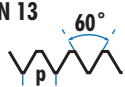

DIN 13

HSSCo
5%

BRILLANTE

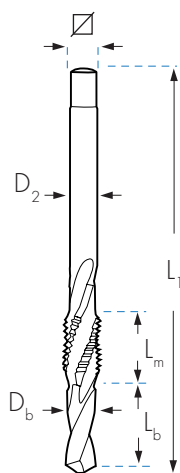
TOL
6HR
CODOLO
RINFORZATODIN
371D
CODOLO
SOTTILEDIN
376

								M8M
		Lb mm	Lm mm	L1 mm	Db mm	D2 mm	∅ mm	€
M 3x0,50	R	9,0	12,5	62,0	2,5	3,5	2,7	32,50
M 4x0,70	R	10,0	16,0	66,0	3,30	4,5	3,4	32,50
M 5x0,80	R	12,5	18,0	75,5	4,20	6,0	4,9	35,07
M 6x1,00	R	14,0	20,0	81,0	5,00	6,0	4,9	38,75
M 8x1,00	R	20,0	14,0	91,0	7,00	6,0	4,9	48,74
M 8x1,25	R	20,0	14,0	91,0	6,75	8,0	6,2	50,25

CODOLO SOTTILE

M 8x1,25	D	20,0	14,0	91,0	6,75	6,0	4,9	45,13
M 10x1,00	D	20,0	15,0	95,0	9,00	7,0	5,5	60,52
M 10x1,50	D	25,0	18,0	105,0	8,50	7,0	5,5	49,32
M 12x1,50	D	24,0	18,0	110,0	10,50	9,0	7,0	65,51
M 12x1,75	D	28,0	20,0	118,0	12,50	11,0	9,0	58,59
M 14x1,50	D	28,0	20,0	118,0	12,50	11,0	9,0	110,93
M 14x2,00	D	28,0	22,0	130,0	12,00	11,0	9,0	107,22
M 16x2,00	D	36,0	24,0	139,0	14,00	12,0	9,0	173,63
M 18x2,50	D	40,0	26,0	151,0	15,50	14,0	11,0	205,65
M 20x2,50	D	45,0	30,0	168,0	17,50	16,0	2,0	347,59

NOTA: Non utilizzare i Punta-Maschi in fori ciechi o passanti più profondi di Lb.

PUNTA MASCHIO SVASATRICE HSSCo STEP CUT

NEW

DIN 13

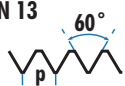
HSSCo
5%

BRILLANTE

TOL
6HD
CODOLO
SOTTILE

1/4"

STEP CUT

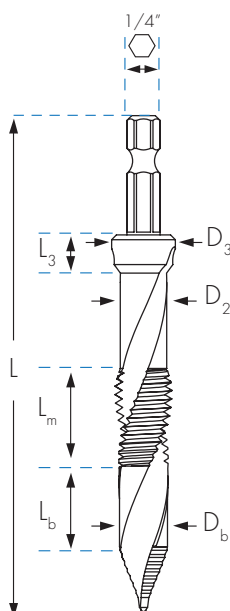

									MTKM	
		Lb mm	Lm mm	L3 mm	L mm	Db mm	D2 mm	D3 mm	∅ mm	€
M 3x0,50	D	7,0	6,0	6,0	57,0	2,5	2,2	7,3	1/4"	23,41
M 4x0,70	D	7,0	8,5	6,0	62,0	3,3	3,0	7,3	1/4"	23,41
M 5x0,80	D	9,0	10,0	6,0	69,0	4,2	3,7	7,3	1/4"	23,41
M 6x1,00	D	10,0	12,0	6,0	73,0	5,0	4,5	7,3	1/4"	23,41
M 8x1,25	D	12,0	16,0	6,0	87,0	6,8	6,3	9,4	1/4"	32,39
M 10x1,50	D	14,0	20,0	6,0	96,0	8,5	8,0	11,4	1/4"	39,05
M 12x1,75	D	16,0	24,0	8,0	112,0	10,3	9,8	13,4	1/4"	56,36

NOTA: Non utilizzare i Punta-Maschio Svasatrice in fori ciechi o passanti più profondi di Lb.

PLACCHETTE PER FILETTATURA ESTERNA

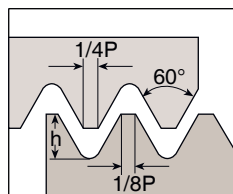
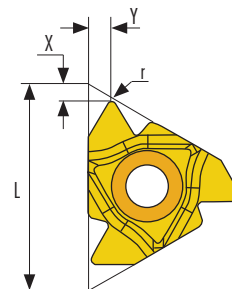
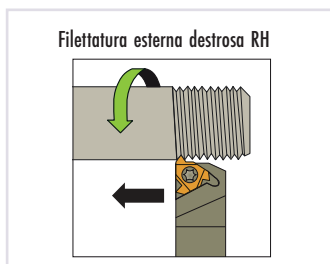
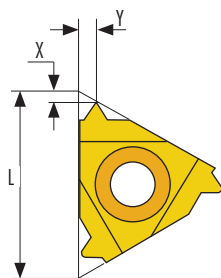

Norma: R262 (DIN 13)
Tolleranza classe: 6g/6H

Profilo totale

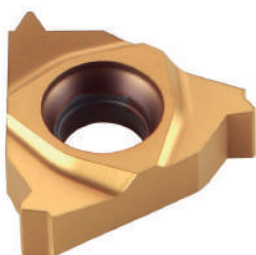
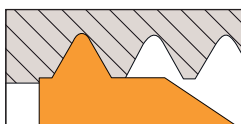

Profilo parziale

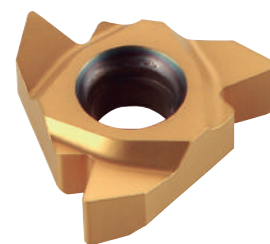
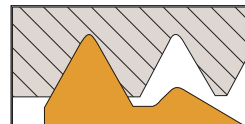

Filettare il profilo completo, terminando il diametro esterno della filettatura. Utilizzeremo una placchetta differente per ogni passo.

Non terminare il diametro esterno della filettatura.

La stessa placchetta può essere utilizzata per una gamma di differenti passi aventi lo stesso angolo di filettatura.

PROFILO TOTALE 60°

FILETTATURA ESTERNA	L	PASSO	h	X	Y	€
PRE-16-075	16	0,75	0,46	0,6	0,6	26,94*
PRE-16-100		1,00	0,61	0,7	0,7	26,94*
PRE-16-125		1,25	0,77	0,8	0,9	26,94*
PRE-16-150		1,50	0,92	0,8	1	26,94*
PRE-16-175		1,75	1,07	0,9	1,2	26,94*
PRE-16-200		2,00	1,23	1	1,3	26,94*
PRE-16-250		2,50	1,53	1,1	1,5	26,94*
PRE-16-300		3,00	1,84	1,2	1,6	26,94*

*Fino ad esaurimento scorte.

PROFILO PARZIALE 60°

FILETTATURA ESTERNA	L	INTERVALLI METRICI	INTERVALLI POLLICI	r	X	Y	€
PPRE-16-150	16	0,50-1,50	48 - 16	0,05	0,80	0,90	26,94*

*Fino ad esaurimento scorte.

PORTAUTENSILI DA FILETTATURA ESTERNA

FILETTATURA ESTERNA	H1=H=B=F	L1	L2	€
PEXT-25-16	25	153	30	197,03*

*Fino ad esaurimento scorte.

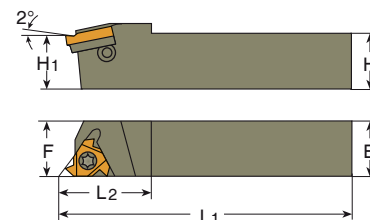

FORMULA MATEMATICA PER RICAIVARE LA VELOCITÀ DI GIRO DEL PEZZO (RPM)

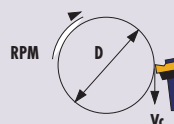

$$RPM = \frac{1000 \times Vc}{\pi \times D}$$

RPM: Rotazioni x minuto
Vc: Velocità di taglio (m/mm)
D: Diametro pezzo (mm)

le RPM si ricavano in funzione di Vc e D

	Vc		Vc
ACCIAIO DOLCE 70 kg/mm ²	25 m / min	ALLUMINIO	50 m / min
ACCIAIO TRATTATO 120 kg/mm ²	13 m / min	TITANIO	18 m / min
INOX	11 m / min	GHISA	25 m / min
		OTTONE	50 m / min

PLACCHETTE PER FILETTATURA INTERNA

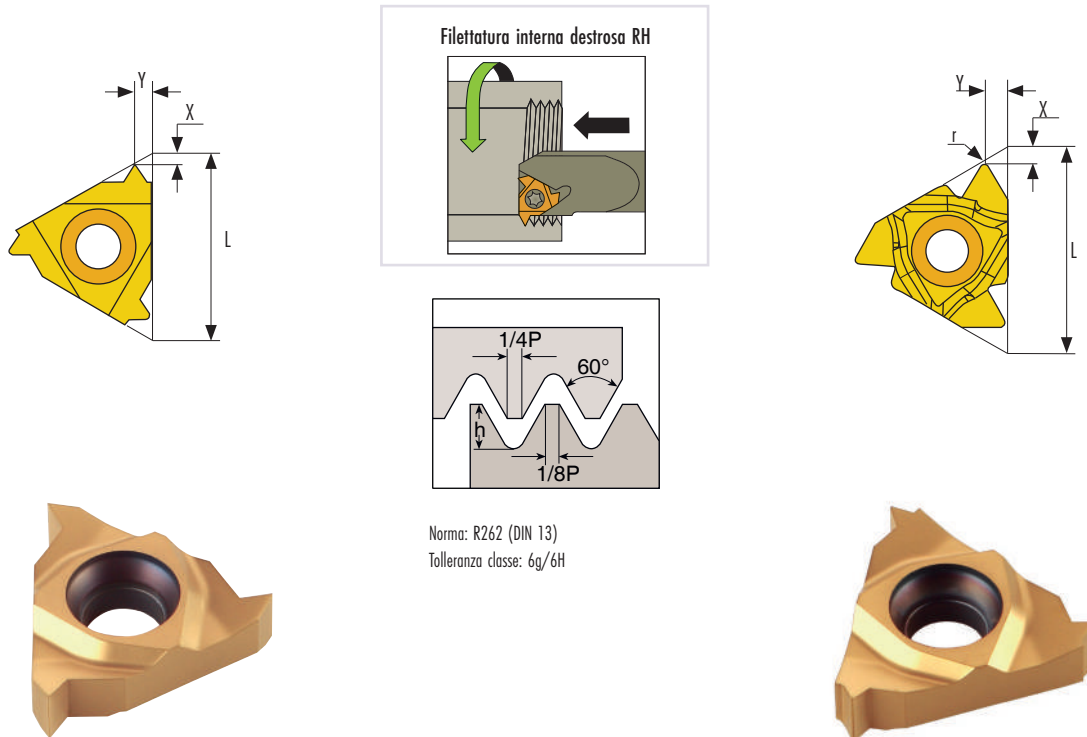

Norma: R262 (DIN 13)
Tolleranza classe: 6g/6H

PROFILO TOTALE 60°

FILETTATURA INTERNA	L	PASSO	h	X	Y	€
PRI-16-075	16	0,75	0,43	0,6	0,6	26,94*
PRI-16-100		1,00	0,58	0,6	0,7	26,94*
PRI-16-125		1,25	0,72	0,8	0,9	26,94*
PRI-16-150		1,50	0,87	0,8	1,0	26,94*
PRI-16-175		1,75	1,01	0,9	1,2	26,94*
PRI-16-200		2,00	1,15	1,0	1,3	26,94*
PRI-16-250		2,50	1,44	1,1	1,5	26,94*
PRI-16-300		3,00	1,73	1,1	1,5	26,94*

*Fino ad esaurimento scorte.

PROFILO PARZIALE 60°

FILETTATURA INTERNA	L	INTERVALLI METRICI	INTERVALLO POLLICI	r	X	Y	€
PPRI-16-150	16	0,50-1,50	48 - 16	0,05	0,80	0,90	26,94*
PPRI-16-300		1,75-3,00	14 - 8	0,16	1,20	1,70	26,94*

*Fino ad esaurimento scorte.

PORTAUTENSILI DA FILETTATURA INTERNA

FILETTATURA INTERNA	L	L1	D	D1	A	Ø MIN. FORO	€
PINT-25-16	200	45	25	24,6	22,6	29	237,45*

*Fino ad esaurimento scorte.

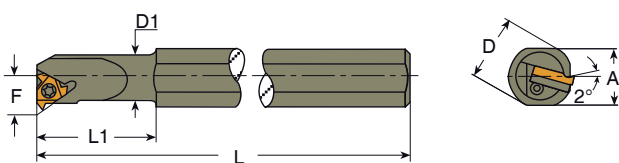

SET DI MASCHI A MACCHINA HSSCo IN SCATOLE METALLICHE

**USO
GENERALE**

**HSSCo
5%**

Maschi e Filiere

Rosa



Ref. JM6



Ref. JM2



Ref. JM8



Ref. JM4

CONTENUTO

	FORMA C	FORMA B	15°	35°	HSS	HSSCo 5% €
JM5	M3 - M4 - M5 - M6 M8 - M10 - M12	-	-	-	-	113,22
JM1	M3 - M4 - M5 - M6 M8 - M10 - M12	-	-	-	2.5/3.3/4.2/5.0/6.8/8.5/10.2 mm	139,26
JM6	-	M3 - M4 - M5 - M6 M8 - M10 - M12	-	-	-	119,97
JM2	-	M3 - M4 - M5 - M6 M8 - M10 - M12	-	-	2.5/3.3/4.2/5.0/6.8/8.5/10.2 mm	146,00
JM7	-	-	M3 - M4 - M5 - M6 M8 - M10 - M12	-	-	153,92
JM3	-	-	M3 - M4 - M5 - M6 M8 - M10 - M12	-	2.5/3.3/4.2/5.0/6.8/8.5/10.2 mm	179,96
JM8	-	-	-	M3 - M4 - M5 - M6 M8 - M10 - M12	-	141,82
JM4	-	-	-	M3 - M4 - M5 - M6 M8 - M10 - M12	2.5/3.3/4.2/5.0/6.8/8.5/10.2 mm	167,86



ASSORTIMENTI DI MASCHI A MACCHINA IN SCATOLE METALLICHE

Plus





Ref. JMPT2

CONTENUTO

	FORMA B	BRILLANTE	 35°	BRILLANTE	 HSSCo 5%	HSS PM €		TiN €
JMP6	M3 - M4 - M5 - M6 M8 - M10 - M12		-		-	135,78	JMPT6	196,64
JMP2	M3 - M4 - M5 - M6 M8 - M10 - M12		-		2.5/3.3/4.2/5.0/6.8/8.5/10.2 mm	183,80	JMPT2	244,66
JMP8	-		M3 - M4 - M5 - M6 M8 - M10 - M12		-	157,86	JMPT8	215,51
JMP4	-		M3 - M4 - M5 - M6 M8 - M10 - M12		2.5/3.3/4.2/5.0/6.8/8.5/10.2 mm	205,87	JMPT4	263,53



INOX

CONTENUTO

	FORMA B	OX	 35°	OX	 HSSCo 5%	HSS PM €		TiN €
JMX6	M3 - M4 - M5 - M6 M8 - M10 - M12		-		-	152,95	JMXT6	186,12
JMX2	M3 - M4 - M5 - M6 M8 - M10 - M12		-		2.5/3.3/4.2/5.0/6.8/8.5/10.2 mm	200,96	JMXT2	234,14
JMX8	-		M3 - M4 - M5 - M6 M8 - M10 - M12		-	187,01	JMXT8	215,67
JMX4	-		M3 - M4 - M5 - M6 M8 - M10 - M12		2.5/3.3/4.2/5.0/6.8/8.5/10.2 mm	235,03	JMXT4	263,68

1200
N/mm²

CONTENUTO

	FORMA B	OX	 35°	OX	 HSSCo 5%	HSS V3 €		TINALOX €
JMMD6	M3 - M4 - M5 - M6 M8 - M10 - M12		-		-	170,08	JMMDT6	243,27
JMMD2	M3 - M4 - M5 - M6 M8 - M10 - M12		-		2.5/3.3/4.2/5.0/6.8/8.5/10.2 mm	218,10	JMMDT2	291,29
JMMD8	-		M3 - M4 - M5 - M6 M8 - M10 - M12		-	186,61	JMMDT8	278,66
JMMD4	-		M3 - M4 - M5 - M6 M8 - M10 - M12		2.5/3.3/4.2/5.0/6.8/8.5/10.2 mm	234,63	JMMDT4	326,69

ASSORTIMENTI DI MASCHI A MACCHINA IN SCATOLE METALLICHE



Ref. JMC2

CONTENUTO

	FORMA B	TiCN	15°	TiCN	HSSCo 5%	HSS-PM
						€
JMC6	M3 - M4 - M5 - M6 - M8 - M10 - M12		-		-	278,89
JMC2	M3 - M4 - M5 - M6 - M8 - M10 - M12		-		2.5/3.3/4.2/5.0/6.8/8.5/10.2 mm	326,91
JMC8	-		M3 - M4 - M5 - M6 - M8 - M10 - M12		-	314,79
JMC4	-		M3 - M4 - M5 - M6 - M8 - M10 - M12		2.5/3.3/4.2/5.0/6.8/8.5/10.2 mm	362,82

QUALSIASI TERRENO

CONTENUTO

	FORMA B	TiN	35°	TiN	HSSCo 5%	HSSCo 5%
						€
JMD6	M3 - M4 - M5 - M6 - M8 - M10 - M12		-		-	230,93
JMD2	M3 - M4 - M5 - M6 - M8 - M10 - M12		-		2.5/3.3/4.2/5.0/6.8/8.5/10.2 mm	278,93
JMD8	-		M3 - M4 - M5 - M6 - M8 - M10 - M12		-	263,58
JMD4	-		M3 - M4 - M5 - M6 - M8 - M10 - M12		2.5/3.3/4.2/5.0/6.8/8.5/10.2 mm	311,61

AI

CONTENUTO

	DENTI ALTERNATI	BRILLANTE	2 CANALI	BRILLANTE	HSS	HSSCo 5%
						€
JMAL6	M3 - M4 - M5 - M6 - M8 - M10 - M12		-		-	162,92
JMAL2	M3 - M4 - M5 - M6 - M8 - M10 - M12		-		2.5/3.3/4.2/5.0/6.8/8.5/10.2 mm	189,68
JMAL8	-		M3 - M4 - M5 - M6 - M8 - M10 - M12		-	191,59
JMAL4	-		M3 - M4 - M5 - M6 - M8 - M10 - M12		2.5/3.3/4.2/5.0/6.8/8.5/10.2 mm	217,64

MASCHI A MACCHINA IN ASTUCCI

USO
GENERALE

CONTENUTO

	FORMA B	BRILLANTE	35°	BRILLANTE	HSSCo 5%	€
PT01	M4 - M5 - M6 - M8 - M10		M4 - M5 - M6 - M8 - M10			154,07



Ref. PT01

Plus

CONTENUTO

	FORMA B	BRILLANTE	35°	BRILLANTE	HSS PM	TiN	€
PT02	M4 - M5 - M6 - M8 - M10		M4 - M5 - M6 - M8 - M10				169,53
PT03							248,92



Ref. PT03

INOX

CONTENUTO

	FORMA B	OX	35°	OX	HSS PM	TiN	€
PT05	M4 - M5 - M6 - M8 - M10		M4 - M5 - M6 - M8 - M10				197,15
PT13							237,02



Ref. PT05

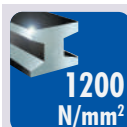

CONTENUTO

	FORMA B	OX	35°	OX	HSS V3	TINALOX	€
PT04	M4 - M5 - M6 - M8 - M10		M4 - M5 - M6 - M8 - M10				209,19
PT14							313,56



Ref. PT04

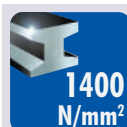

CONTENUTO

	FORMA B	TiCN	15°	TiCN	HSS PM	€
PT11	M4 - M5 - M6 - M8 - M10		M4 - M5 - M6 - M8 - M10			361,60



Ref. PT11

MASCHI A MACCHINA IN ASTUCCI

Maschi e Filiere

Rosa

AI



Ref. PT06

CONTENUTO

	DENTI ALTERN.	2 CANALI	HSSCo 5% €
PT06	M4 - M5 - M6 M8 - M10	M4 - M5 - M6 M8 - M10	209,87

GHISA



Ref. PT07

CONTENUTO

	FORMA C	HSSCo 5% €
PT07	M4 - M5 - M6 - M8 - M10 M4 - M5 - M6 - M8 - M10	170,90

OTTONE



Ref. PT10

CONTENUTO

	FORMA C	HSSCo 5% €
PT10	M4 - M5 - M6 - M8 - M10 M4 - M5 - M6 - M8 - M10	207,73

LAMINAZIONE



Ref. PT08

CONTENUTO

		HSSCo 5% €
PT08	M4 - M5 - M6 - M8 - M10 M4 - M5 - M6 - M8 - M10	347,00





Ref. PT09

CONTENUTO

		HSSCo 5% €
PT09	M4 - M5 - M6 - M8 - M10 M4 - M5 - M6 - M8 - M10	384,99

TOL 6G



Ref. PT12

CONTENUTO

	FORMA B	 35°	HSSCo 5% €
PT12	M4 - M5 - M6 M8 - M10	M4 - M5 - M6 M8 - M10	186,32

ESPOSITORI IN METACRILATO PER MASCHI A MACCHINA

ESPOSITORE IN METACRILATO

MM-03

Composizione: Maschi a macchina, Serie Normale

HSSCo
5%FORMA
B

Fori passanti, Ref. M2

M4	M5	M6	M8	M10	M12	M14
5	10	10	10	10	5	4



Fori ciechi, Ref. M4

M4	M5	M6	M8	M10	M12	M14
5	10	10	10	10	5	4

Dimensioni: larghezza 240 x profondità 240 x altezza 245 mm

2.016,85 €



Ref. MM-03



Ref. MM-04

ESPOSITORE IN METACRILATO

MM-04

Composizione: Maschi a macchina, Serie Plus
Fabbricati in acciaio sinterizzato PMHSS
PM

Plus

FORMA
B

Fori passanti, Ref. M2

M4	M5	M6	M8	M10	M12	M14
5	10	10	10	10	5	4



Fori ciechi, Ref. M4

M4	M5	M6	M8	M10	M12	M14
5	10	10	10	10	5	4

Dimensioni: larghezza 240 x profondità 240 x altezza 245 mm

2.322,55 €

ESPOSITORE IN METACRILATO

MM-05

Composizione: Maschi a macchina per lavorazioni speciali

FORMA
B

Fori passanti Ref. M2



M4	M5	M6	M8	M10	M12	M14
1	2	2	2	2	1	1



M4	M5	M6	M8	M10	M12	M14
1	2	2	2	2	1	1



M4	M5	M6	M8	M10	M12	M14
1	2	2	2	2	1	1



M4	M5	M6	M8	M10	M12	M14
1	2	2	2	2	1	1



M4	M5	M6	M8	M10	M12
1	2	2	2	2	1



Fori ciechi, Ref. M4



M4	M5	M6	M8	M10	M12	M14
1	2	2	2	2	1	1



M4	M5	M6	M8	M10	M12	M14
1	2	2	2	2	1	1



M4	M5	M6	M8	M10	M12	M14
1	2	2	2	2	1	1



M4	M5	M6	M8	M10	M12	M14
1	2	2	2	2	1	1



M4	M5	M6	M8	M10	M12
1	2	2	2	2	1

Dimensioni: larghezza 240 x profondità 240 x altezza 245 mm

3.097,38 €