

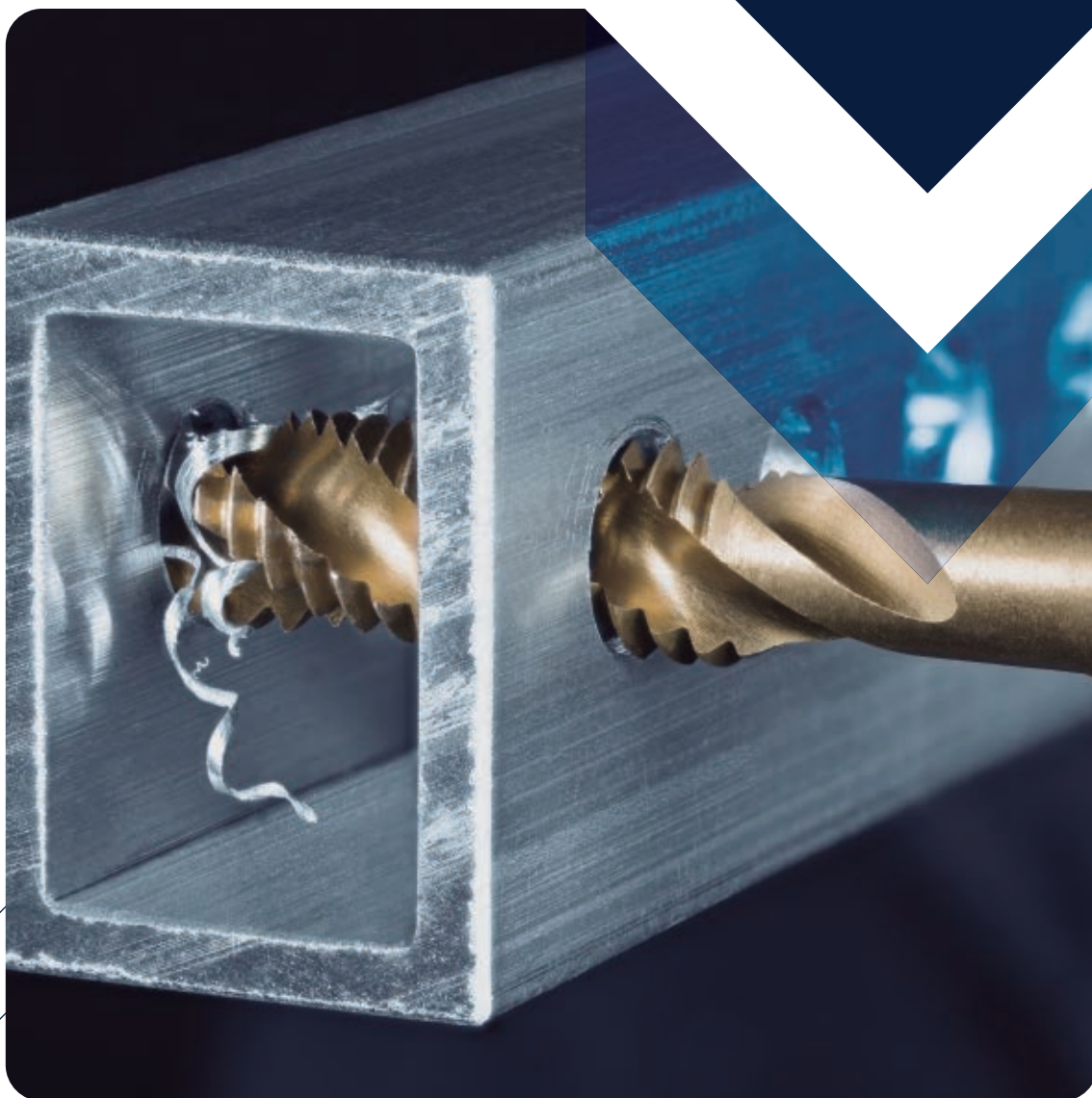

BLUE-MASTER[®]
by *CE/ESA*



MACHOS
E CAÇONETES

JOGOS DE MACHOS E CAÇONETES HSS PARA ROSCAGEM MANUAL

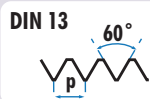

Ref. M0

HSS

(M)

DIN
352

(MF)

DIN
2181TOL
6H

Ref. C5

HSS

DIN
223TOL
6g

Para materiais até 38HRc

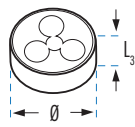
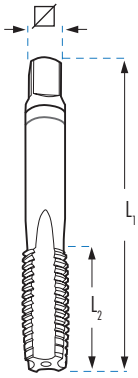

Uds.	Ø	L1 x L2 x mm	M0		C5	
			€	Ø x L3 mm	€	€
M 5,5x0,90	3	4,60	50 x 16 x 4,9	95,70	25 x 9	109,86
M 6x0,50	2	5,50	50 x 14 x 4,9	32,50	20 x 5	42,50
M 6x0,75	2	5,25	50 x 14 x 4,9	27,43	25 x 9	34,86
M 6x1,00	3	5,00	50 x 19 x 4,9	24,29*	25 x 9	31,02*
M 6x1,25	3	4,75	50 x 19 x 4,9	157,01	25 x 9	112,49
M 7x0,75	2	6,25	50 x 14 x 4,9	36,01	25 x 9	34,51
M 7x1,00	3	6,00	50 x 19 x 4,9	29,59*	25 x 9	32,56*
M 7x1,25	3	5,75	50 x 19 x 4,9	109,10	25 x 9	135,20
M 8x0,50	2	7,50	50 x 16 x 4,9	57,32	25 x 9	51,53
M 8x0,75	2	7,25	50 x 16 x 4,9	37,73	25 x 9	37,32
M 8x1,00	2	7,00	56 x 18 x 4,9	27,30*	25 x 9	35,98*
M 8x1,25	3	6,80	56 x 22 x 4,9	29,56*	25 x 9	32,91*
M 8x1,50	3	6,50	56 x 22 x 4,9	106,11	25 x 9	117,54
M 9x1,00	2	8,00	63 x 18 x 5,5	39,97	25 x 9	39,99
M 9x1,25	3	7,80	63 x 22 x 5,5	48,43*	25 x 9	38,25*
M 10x0,50	2	9,50	63 x 18 x 5,5	59,10	30 x 10	129,87
M 10x0,75	2	9,25	63 x 18 x 5,5	60,43	30 x 11	63,85
M 10x1,00	2	9,00	63 x 18 x 5,5	29,23	38 x 10	42,34
M 10x1,25	2	8,80	70 x 24 x 5,5	29,63	38 x 10	45,16
M 10x1,50	3	8,50	70 x 24 x 5,5	36,45*	38 x 10	44,05*
M 11x0,75	2	10,25	63 x 18 x 6,2	88,73	30 x 11	140,31
M 11x1,00	2	10,00	63 x 18 x 6,2	55,90	30 x 11	66,82
M 11x1,25	2	9,75	63 x 20 x 6,2	55,90	30 x 11	66,81
M 11x1,50	3	9,50	70 x 24 x 6,2	60,76	38 x 10	53,37
M 12x0,75	2	11,25	70 x 20 x 7,0	80,68	38 x 10	72,45
M 12x1,00	2	11,00	70 x 20 x 7,0	51,83	38 x 10	63,85
M 12x1,25	2	10,75	70 x 20 x 7,0	51,68	38 x 10	61,56
M 12x1,50	2	10,50	70 x 20 x 7,0	44,03*	38 x 10	55,21*
M 12x1,75	3	10,20	75 x 29 x 7,0	51,28*	38 x 14	47,86*
M 13x0,75	2	12,25	70 x 20 x 9,0	91,18	38 x 10	127,74
M 13x1,00	2	12,00	70 x 20 x 9,0	87,78	38 x 10	67,84
M 13x1,25	2	11,75	70 x 20 x 9,0	80,13	38 x 10	90,71
M 13x1,50	2	11,50	70 x 20 x 9,0	80,13	38 x 10	71,31
M 13x1,75	3	11,25	70 x 20 x 9,0	92,72	38 x 14	76,41
M 14x0,75	2	13,25	70 x 20 x 9,0	104,78	38 x 10	119,77
M 14x1,00	2	13,00	70 x 20 x 9,0	80,78	38 x 10	71,61
M 14x1,25	2	12,80	70 x 20 x 9,0	63,10*	38 x 10	71,61*
M 14x1,50	2	12,50	70 x 20 x 9,0	49,07	38 x 10	60,96
M 14x1,75	2	12,25	70 x 20 x 9,0	98,13	38 x 14	203,96
M 14x2,00	3	12,00	80 x 30 x 9,0	56,73*	38 x 14	47,39*
M 15x1,00	2	14,00	70 x 20 x 9,0	113,18	45 x 14	77,11
M 15x1,25	2	13,75	70 x 20 x 9,0	117,27	45 x 14	119,46
M 15x1,50	2	13,50	70 x 20 x 9,0	104,99	45 x 14	82,61
M 15x2,00	3	13,00	80 x 30 x 9,0	113,43	45 x 14	103,55
M 16x1,00	2	15,00	70 x 20 x 9,0	107,16	45 x 14	87,31
M 16x1,25	2	14,75	70 x 20 x 9,0	112,80	45 x 14	73,46
M 16x1,50	2	14,50	70 x 20 x 9,0	61,06*	45 x 14	68,58*
M 16x2,00	3	14,00	80 x 32 x 9,0	81,17*	45 x 18	64,25*
M 17x1,00	2	16,00	70 x 20 x 9,0	173,07	45 x 14	124,94
M 17x1,25	2	15,75	70 x 20 x 9,0	173,07	45 x 14	124,94
M 17x1,50	2	15,50	70 x 20 x 9,0	173,07	45 x 14	124,94
M 18x1,00	2	17,00	80 x 22 x 11,0	119,14	45 x 14	92,32
M 18x1,25	2	16,75	80 x 22 x 11,0	170,07	45 x 14	96,02

* Consulte o preço dos jogos de machos e caçonetes à esquerda disponíveis na Pag.188

* Sobrecusto por caçonetes abertos +20% sobre os preços indicados.

JOGOS DE MACHOS E CAÇONETES HSS PARA ROSCAGEM MANUAL

DIN 13

60°

Ref. M0

(M)
HSS

DIN
352

DIN
2181

TOL
6H

Ref. C5

HSS

DIN
223

TOL
6g

		M0					C5							M0					C5				
		Uds.	Ø	L1 x L2 x mm	€	Ø x L3 mm	Uds.	Ø	L1 x L2 x mm	€	Ø x L3 mm			Uds.	Ø	L1 x L2 x mm	€	Ø x L3 mm	Uds.	Ø	L1 x L2 x mm	€	Ø x L3 mm
M 18x1,50	2	16,50	80 x 22 x 11,0	80,44	45 x 14	83,06	M 33x3,50	3	29,5	125 x 50 x 20,0	390,08*	65 x 25	147,36*										
M 18x2,00	2	16,00	80 x 22 x 11,0	128,40*	45 x 14	92,80*	M 34x1,50	2	32,5	100 x 25 x 22,0	400,85	65 x 18	168,65										
M 18x2,50	3	15,50	95 x 40 x 11,0	107,13*	45 x 18	64,28*	M 34x2,00	2	32,0	100 x 25 x 22,0	479,38	65 x 18	384,96										
M 19x1,00	2	18,00	80 x 22 x 11,0	251,18	45 x 14	154,96	M 35x1,50	2	33,5	100 x 25 x 22,0	427,97	65 x 18	174,93										
M 19x1,25	2	17,75	80 x 22 x 11,0	251,18	45 x 14	175,26	M 35x2,00	2	33,0	100 x 25 x 22,0	479,38	65 x 18	300,20										
M 19x1,50	2	17,50	80 x 22 x 11,0	251,18	45 x 14	154,96	M 36x1,50	2	34,5	100 x 25 x 22,0	417,83	65 x 18	165,60										
M 19x2,00	2	17,00	80 x 22 x 11,0	298,17	45 x 14	177,03	M 36x2,00	2	34,0	125 x 33 x 22,0	550,33	65 x 18	172,71										
M 20x1,00	2	19,00	80 x 22 x 12,0	162,19	45 x 14	92,32	M 36x3,00	2	33,0	125 x 33 x 22,0	713,13*	65 x 25	173,28*										
M 20x1,25	2	18,75	80 x 22 x 12,0	250,26	45 x 14	200,36	M 36x4,00	3	32,0	150 x 53 x 22,0	502,21*	65 x 25	150,23*										
M 20x1,50	2	18,50	80 x 22 x 12,0	100,74	45 x 14	84,98	M 38x1,50	2	36,5	100 x 25 x 22,0	482,93	75 x 20	253,02										
M 20x2,00	2	18,00	80 x 22 x 12,0	136,00*	45 x 14	92,32*	M 38x2,00	2	36,0	125 x 25 x 22,0	649,97	75 x 20	373,86										
M 20x2,50	3	17,50	95 x 40 x 12,0	120,18*	45 x 18	63,27*	M 39x1,50	2	37,5	110 x 25 x 24,0	639,19	75 x 20	251,67										
M 21x1,00	2	20,00	80 x 22 x 12,0	321,81	45 x 14	189,84	M 39x2,00	2	37,0	125 x 23 x 24,0	639,19	75 x 20	265,78										
M 21x1,25	2	19,75	80 x 22 x 12,0	321,81	45 x 14	189,84	M 39x3,00	2	36,0	125 x 33 x 24,0	616,56*	75 x 30	271,46*										
M 21x1,50	2	19,50	80 x 22 x 12,0	250,52	45 x 14	200,68	M 39x4,00	3	35,0	150 x 53 x 24,0	561,94*	75 x 30	228,51*										
M 22x1,00	2	21,00	80 x 22 x 14,5	181,77	55 x 16	124,27	M 40x1,50	2	38,5	110 x 25 x 24,0	567,12	75 x 20	264,37										
M 22x1,25	2	20,75	80 x 22 x 14,5	247,85	55 x 16	202,51	M 40x2,00	2	38,0	125 x 33 x 24,0	624,51	75 x 20	245,49										
M 22x1,50	2	20,50	80 x 22 x 14,5	110,80	55 x 16	106,90	M 40x3,00	2	37,0	125 x 33 x 24,0	622,22	75 x 30	267,74										
M 22x2,00	2	20,00	80 x 22 x 14,5	176,74*	55 x 16	118,94*	M 42x1,50	2	40,5	110 x 25 x 24,0	616,44	75 x 20	293,95										
M 22x2,50	3	19,50	100 x 40 x 14,5	160,08*	55 x 22	95,08*	M 42x2,00	2	40,0	125 x 33 x 24,0	730,75	75 x 20	310,82										
M 23x1,00	2	22,00	80 x 22 x 14,5	324,61	55 x 16	205,35	M 42x3,00	2	39,0	125 x 33 x 24,0	733,90	75 x 30	293,95										
M 23x1,50	2	21,50	80 x 22 x 14,5	323,35	55 x 16	243,45	M 42x4,50	3	37,5	150 x 53 x 24,0	703,09	75 x 30	228,49										
M 24x1,00	2	23,00	90 x 22 x 14,5	196,13	55 x 16	121,20	M 45x1,50	2	43,5	110 x 25 x 29,0	673,32	90 x 22	343,49										
M 24x1,25	2	22,75	90 x 22 x 14,5	320,56	55 x 16	160,91	M 45x2,00	2	43,0	125 x 33 x 29,0	877,59	90 x 22	372,89										
M 24x1,50	2	22,50	90 x 22 x 14,5	141,24	55 x 16	108,92	M 45x3,00	2	42,0	125 x 33 x 29,0	877,59	90 x 36	389,06										
M 24x2,00	2	22,00	90 x 22 x 14,5	210,75*	55 x 16	121,20*	M 45x4,50	3	40,5	160 x 60 x 29,0	811,67	90 x 36	354,06										
M 24x3,00	3	21,00	110 x 50 x 14,5	190,94*	55 x 22	95,08*	M 48x1,50	2	46,5	140 x 33 x 29,0	751,72	90 x 22	335,65										
M 25x1,00	2	24,00	90 x 22 x 14,5	276,69	55 x 16	183,94	M 48x2,00	2	46,0	140 x 33 x 29,0	1.146,95	90 x 22	367,66										
M 25x1,25	2	23,75	90 x 22 x 14,5	362,36	55 x 16	242,19	M 48x3,00	2	45,0	140 x 33 x 29,0	1.063,46	90 x 36	354,68										
M 25x1,50	2	23,50	90 x 22 x 14,5	261,04	55 x 16	158,22	M 48x5,00	3	43,0	180 x 65 x 29,0	977,24	90 x 36	354,48										
M 25x2,00	2	23,00	90 x 22 x 14,5	471,88	55 x 16	235,47	M 50x1,50	2	48,5	140 x 33 x 29,0	822,10	90 x 22	350,00										
M 26x1,00	2	25,00	90 x 22 x 14,5	247,33	55 x 16	182,31	M 50x3,00	2	57,0	140 x 33 x 29,0	1.097,87	90 x 22	381,44										
M 26x1,50	2	24,50	90 x 22 x 14,5	232,06	55 x 16	146,98	M 52x1,50	2	50,5	140 x 33 x 32,0	862,35	90 x 22	357,40										
M 26x2,00	2	24,00	90 x 22 x 14,5	272,28	55 x 16	206,02	M 52x2,00	2	50,0	140 x 33 x 32,0	1.251,19	90 x 22	415,35										
M 27x1,00	2	26,00	90 x 22 x 16,0	272,30	65 x 18	164,00	M 52x3,00	2	49,0	140 x 33 x 32,0	1.151,95	90 x 36	453,25										
M 27x1,50	2	25,50	90 x 22 x 16,0	262,92	65 x 18	164,70	M 52x5,00	3	47,0	180 x 65 x 32,0	1.170,45	90 x 36	354,48										
M 27x2,00	2	25,00	90 x 22 x 16,0	292,08*	65 x 18	179,13*	M 56x4,00	2	52,0	180 x 47 x 32,0	1.284,50	105 x 36											
M 27x3,00	3	24,00	110 x 50 x 16,0	241,45*	65 x 25	144,22*	M 56x5,50	3	50,5	200 x 85 x 35,0	1.816,67	105 x 36											
M 28x1,00	2	27,00	90 x 22 x 16,0	459,59	65 x 18	212,00	M 60x5,50	3	54,5	200 x 85 x 35,0	1.887,89	105 x 36											
M 28x1,50	2	26,50	90 x 22 x 16,0	257,79	65 x 18	149,31	M 64x4,00	2	60,0	180 x 50 x 35,0	1.809,03	120 x 36											
M 28x2,00	2	26,00	90 x 22 x 16,0	308,43	65 x 18	209,93	M 64x6,00	3	58,0	220 x 90 x 39,0	2.233,84	120 x 36											
M 30x1,00	2	29,00	90 x 22 x 18,0	286,27	65 x 18	173,80	M 68x6,00	3	62,0	220 x 90 x 39,0	2.674,33	120 x 36											
M 30x1,50	2	28,50	90 x 22 x 18,0	274,73	65 x 18	164,69	M 72x6,00	3	66,0	235 x 90 x 39,0	2.897,34	120 x 36											
M 30x2,00	2	28,00	90 x 22 x 18,0	316,74	65 x 18	182,52																	
M 30x3,00	2	27,00	125 x 56 x 18,0	309,64*	65 x 25	203,31*																	
M 30x3,50	3	26,50	125 x 50 x 18,0	310,65*	65 x 25	144,59*																	
M 32x1,00	2	31,00	90 x 22 x 18,0	377,52	65 x 18	224,48																	
M 32x1,50	2	30,50	90 x 22 x 18,0	327,12	65 x 18	170,81																	
M 32x2,00	2	30,00	90 x 22 x 18,0	468,23	65 x 18	208,05																	
M 33x1,00	2	32,00	100 x 25 x 20,0	602,47	65 x 18	237,69																	
M 33x1,50	2	31,50	100 x 25 x 20,0	349,86	65 x 18	161,63																	
M 33x2,00	2	31,00	100 x 25 x 20,0	441,71	65 x 18	162,74																	
M 33x3,00	2	30,00	125 x 56 x 20,0	557,35*	65 x 25	251,14*																	

CAÇONETES COM MEDIDA EXTERIOR EM POLEGADAS									
					C5				
		Ø x L3 mm	€			Ø x L3 mm	€		
M 3x0,50	25,4 x 9,5	26,59	M 8x1,25	38,1 x 12,7	28,22				
M 4x0,70	25,4 x 9,5	26,59	M 10x1,50	25,4 x 9,50	35,72				
M 5x0,80	25,4 x 9,5	27,09	M 10x1,50	38,1 x 12,7	35,72				
M 6x1,00	25,4 x 9,5	26,59	M 12x1,75	25,4 x 9,50	43,04				
M 8x1,25	25,4 x 9,5	28,22	M 12x1,75	38,1 x 12,7	43,04				

* Consulte o preço dos jogos de machos e caçonetes à esquerda disponíveis na Pag.188
* Sobrecusto por caçonetes abertos +20% sobre os preços indicados.

JOGOS DE MACHOS E CAÇONETES HSS PARA ROSCAGEM MANUAL

UNC

Ref. M0

HSS

DIN
351TOL
2B

Ref. C5

HSS

DIN
223TOL
2a

UNF

Ref. M0

HSS

DIN
2181TOL
2B

Ref. C5

HSS

DIN
223TOL
2a

Icon	Uds.	D1 mm	Ø	L1 x L2 x mm	M0		C5	
					€	Ø x L3 mm	€	€
UNC n°1-64h.	3	1,85	1,50	36x8x2,1	113,74	16x5		
UNC n°2-56h.	3	2,18	1,80	36x9x2,1	80,38	16x5		
UNC n°3-48h.	3	2,51	2,10	40x9x2,1	80,38	16x5		
UNC n°4-40h.	3	2,84	2,25	40x11x2,7	60,87	20x5	45,17	
UNC n°5-40h.	3	3,17	2,60	40x11x2,7	58,20	20x5	45,29	
UNC n°6-32h.	3	3,50	2,75	45x13x3,0	58,20	20x7	45,29	
UNC n°8-32h.	3	4,17	3,50	45x13x3,4	58,20	20x7	45,29	
UNC n°10-24h.	3	4,83	3,90	50x16x4,9	58,20	20x7	45,29	
UNC n°12-24h.	3	5,49	4,50	50x19x4,9	58,20	20x7	45,29	
UNC 1/4-20h.	3	6,35	5,10	50x19x4,9	49,87*	20x7	42,68*	
UNC 5/16-18h.	3	7,94	6,60	56x22x4,9	56,62*	25x9	43,80*	
UNC 3/8-16h.	3	9,52	8,00	70x24x5,5	64,42*	30x11	60,89*	
UNC 7/16-14h.	3	11,11	9,40	70x24x6,2	83,88	38x14	60,89	
UNC 1/2-13h.	3	12,70	10,75	75x29x7,0	96,51*	38x14	62,59*	
UNC 9/16-12h.	3	14,28	12,20	80x30x9,0	113,94	38x14	65,51	
UNC 5/8-11h.	3	15,87	13,50	80x32x9,0	157,14*	45x18	88,80*	
UNC 3/4-10h.	3	19,05	16,50	95x40x11,0	214,11*	45x18	88,80*	
UNC 7/8-9h.	3	22,22	19,50	100x40x14,5	263,57	55x22	123,97	
UNC 1"-8h.	3	25,40	22,25	110x50x14,5	355,91*	55x22	119,19*	
UNC 1.1/8-7h.	3	28,57	25,00	125x56x18,0	536,62	65x25	177,06	
UNC 1.1/4-7h.	3	31,75	28,00	125x56x18,0	675,44	65x25	177,06	
UNC 1.3/8-6h.	3	34,92	30,75	150x63x22,0	856,88	65x25	177,06	
UNC 1.1/2-6h.	3	38,10	34,00	150x63x24,0	1.052,07	75x30	276,06	
UNC 2"-4,5h.	3	50,80	45,00	180x75x32,0	1.430,05	90x36		

Icon	Uds.	D1 mm	Ø	L1 x L2 x mm	M0		C5	
					€	Ø x L3 mm	€	€
UNF n°2-64h.	2	2,18	1,85	36x8x2,1	72,83			
UNF n°3-56h.	2	2,51	2,15	40x9x2,1	72,83			
UNF n°4-48h.	2	2,84	2,35	40x9x2,7	45,38	20x5	46,94	
UNF n°5-44h.	2	3,17	2,70	45x10x2,7	45,38	20x5	45,29	
UNF n°6-40h.	2	3,50	2,95	45x16x3,0	43,37	20x5	45,29	
UNF n°8-36h.	2	4,17	3,50	50x12x3,4	43,37	20x7	45,29	
UNF n°10-32h.	2	4,83	4,10	50x12x4,9	43,37	20x7	45,29	
UNF n°12-28h.	2	5,49	4,60	50x12x4,9	45,38	20x7	45,29	
UNF 1/4-28h.	2	6,35	5,50	50x14x4,9	33,10*	25x9	39,98*	
UNF 5/16-24h.	2	7,94	6,90	56x22x4,9	35,44*	25x9	44,63*	
UNF 3/8-24h.	2	9,52	8,50	63x20x5,5	40,92*	38x10	60,89*	
UNF 7/16-20h.	2	11,11	9,90	63x20x6,2	54,30	38x10	59,74	
UNF 1/2-20h.	2	12,70	11,50	70x22x7,0	55,56*	38x10	65,09*	
UNF 9/16-18h.	2	14,29	12,90	70x22x9,0	72,40	38x10	68,13	
UNF 5/8-18h.	2	15,87	14,50	70x22x9,0	93,52*	45x14	88,80*	
UNF 3/4-16h.	2	19,05	17,50	80x22x11,0	125,62*	45x14	88,80*	
UNF 7/8-14h.	2	22,22	20,40	80x22x14,5	161,44*	55x16	119,19*	
UNF 1"-12h.	2	25,40	23,25	90x22x16,0	214,06	55x16	119,19	
UNF 1"-14h.	2	25,40	23,60	90x22x14,5	237,14*	55x16	129,51*	
UNF 1.1/8-12h.	2	28,57	26,50	90x22x18,0	315,95	65x18	145,16	
UNF 1.1/4-12h.	2	31,75	29,50	90x22x20,0	385,87	65x18	184,14	
UNF 1.3/8-12h.	2	34,92	32,80	125x35x22,0	520,58	65x18	192,76	
UNF 1.1/2-12h.	2	38,10	36,00	125x40x22,0	657,67	75x20	276,06	
UNF 2"-12h.	2	50,80	48,38	140x40x29,0	1.627,34	90x22		

JOGOS DE MACHOS E CAÇONETES HSS E HSSCO PARA ROSCAGEM MANUAL

BSP (GAS) Ref. M0 **DIN 5157** **TOL ISO 228** Ref. C5 **DIN 5158** Ref. MOT Ref. MOX **DIN 5157** **TOL 6H** Ref. CST Ref. C5X **DIN 5158** **TOL 6g**



Tubo	Uds.	D1 mm	L1 x L2 x mm	M0		C5		MOT		CST		MOX		C5X	
				HSS	€	HSS	€	HSS	€	HSS	€	HSSCo	€	HSSCo	€
G 1/8-28h.	2	9,73	8,80	63 x 20 x 5,5	37,01*	38 x 10	54,45*	G 1/8-28 h.	2	80,55	101,51	92,55	69,02		
G 1/4-19h.	2	13,16	11,80	70 x 22 x 9,0	52,16*	38 x 10	54,16*	G 1/4-19 h.	2	146,54	105,05	166,30	71,19		
G 3/8-19h.	2	16,66	15,25	70 x 22 x 9,0	65,48*	45 x 14	71,73*	G 3/8-19 h.	2	178,79	118,17	206,59	84,69		
G 1/2-14h.	2	20,95	19,00	80 x 22 x 12,0	91,83*	45 x 14	71,73*	G 1/2-14 h.	2	251,98	133,77	278,74	93,71		
G 5/8-14h.	2	22,91	21,00	80 x 22 x 14,5	117,50*	55 x 16	99,51*								
G 3/4-14h.	2	26,44	24,50	90 x 22 x 16,0	143,35*	55 x 16	129,53*	G 3/4-14 h.	2	330,58	217,94	400,09	159,84		
G 7/8-14h.	2	30,20	28,25	90 x 22 x 18,0	192,98	65 x 18	154,20								
G 1"-11h.	2	33,25	30,75	100 x 25 x 20,0	227,25*	65 x 18	155,69*	G 1" -11 h.	2	576,15	291,11	658,06	190,95		
G 1.1/8-11h.	2	37,90	35,50	125 x 40 x 22,0	362,65	75 x 20	219,74								
G 1.1/4-11h.	2	41,91	39,50	125 x 40 x 24,0	395,20*	75 x 20	215,70*								
G 1.3/8-11h.	2	44,32	42,00	125 x 40 x 29,0	536,77	90 x 22	338,02								
G 1.1/2-11h.	2	47,80	45,25	140 x 40 x 29,0	597,26	90 x 22	325,60								
G 1.3/4-11h.	2	53,75	51,25	140 x 40 x 32,0	992,93	105 x 22	338,02								
G 2"-11h.	2	59,61	57,00	160 x 40 x 35,0	1.104,06	105 x 22	406,80								
G 2.1/4-11h.	2	65,71	63,00	160 x 40 x 39,0	1.823,79	105 x 22									
G 2.1/2-11h.	2	75,18	72,50	160 x 40 x 39,0	2.741,36	120 x 22									
G 2.3/4-11h.	2	81,53	79,00	160 x 40 x 39,0	3.324,15	120 x 22									
G 3"-11h.	2	87,88	85,50	160 x 40 x 39,0	3.459,76	150 x 25									
G 4"-11h.	2	113,03	110,50	180 x 45 x 44,0	5.247,27	180 x 25									

UNF 3B Ref. M0 **HSS** **DIN 2181** **TOL 3B**

Tubo	Uds.	D1 mm	L1 x L2 x mm	MO-3B
UNF nº4-48-3B	2	2,84	40x9x2,7	57,80
UNF nº5-44-3B	2	3,17	45x10x2,7	57,80
UNF nº6-40-3B	2	3,50	45x16x3,0	54,53
UNF nº8-36-3B	2	4,17	50x12x3,4	54,53
UNF nº10-32-3B	2	4,83	50x12x4,9	54,53
UNF nº12-28-3B	2	5,49	50x12x4,9	57,80
UNF 1/4-28-3B	2	6,35	50x14x4,9	42,16
UNF 5/16-24-3B	2	7,94	56x22x4,9	45,13
UNF 3/8-24-3B	2	9,52	63x20x5,5	52,11
UNF 7/16-20-3B	2	11,11	63x20x6,2	69,17
UNF 1/2-20-3B	2	12,70	70x22x7,0	70,76

* Consulte o preço dos jogos de machos e caçonetes à esquerda disponíveis na Pag.188

Machos e Caçonetes
Verde
Rosa

JOGOS DE MACHOS E CAÇONETES HSS PARA ROSCAGEM MANUAL

Machos e Caçonetes

Rosa Verde

BSW Ref. M0 HSS DIN 351 TOL Classe 2
Ref. C5 HSS DIN 223

DIN BS84 55°

BSF Ref. M0 HSS DIN 5157 TOL ISO 228
Ref. C5 HSS DIN 223

DIN BS84 55°

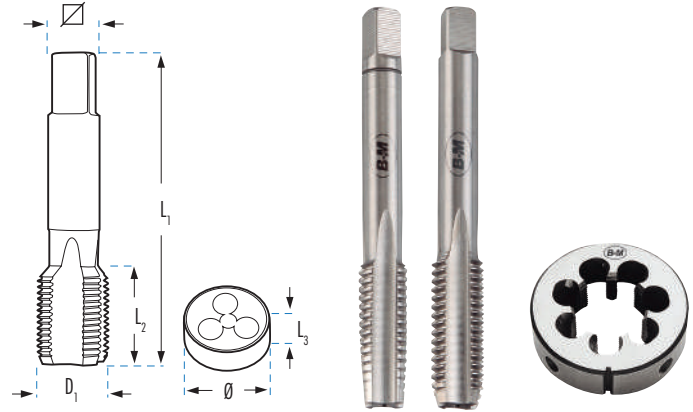

Icon	Uds.	D1 mm	Ø	L1 x L2 x mm	M0		C5	
					€	Ø x L3 mm	€	€
W 1/16-60h.	3	1,59	1,15	32x8x2,1	62,53	16x5	84,15	
W 3/32-48h.	3	2,38	1,80	40x9x2,1	45,72	20x5	43,42	
W 1/8-40h.	3	3,17	2,55	40x14x2,7	32,84*	25x9	34,27*	
W 5/32-32h.	3	3,97	3,10	45x17x3,4	33,18	25x9	34,96	
W 3/16-24h.	3	4,76	3,60	50x19x4,9	32,84	25x9	34,27	
W 7/32-24h.	3	5,55	4,40	50x19x4,9	54,01	25x9	44,76	
W 1/4-20h.	3	6,35	5,10	50x20x4,9	36,99*	25x9	34,96*	
W 5/16-18h.	3	7,94	6,50	56x20x4,9	45,18*	25x9	36,46*	
W 3/8-16h.	3	9,52	7,90	63x22x5,5	49,64*	38x10	52,77*	
W 7/16-14h.	3	11,11	9,25	70x22x6,2	66,63	38x10	52,84	
W 1/2-12h.	3	12,70	10,50	75x25x7,0	71,50	38x14	51,85	
W 9/16-12h.	3	14,29	12,00	80x26x9,0	97,27	38x14	63,32	
W 5/8-11h.	3	15,87	13,40	80x27x9,0	111,86*	45x18	75,30*	
W 11/16-11h.	3	17,46	15,25	95x32x11,0	263,61	45x18	124,04	
W 3/4-10h.	3	19,05	16,50	95x32x11,0	159,24*	45x18	75,42*	
W 7/8-9h.	3	22,22	19,25	100x32x14,5	217,47*	55x22	110,89*	
W 1" - 8h.	3	25,40	21,75	110x36x14,5	266,51*	55x22	111,90*	
W 1.1/8-7h.	3	28,57	24,75	125x40x18,0	395,03	65x25	176,20	
W 1.1/4-7h.	3	31,75	27,75	125x40x18,0	477,94	65x25	176,27	
W 1.3/8-6h.	3	34,92	30,50	150x50x22,0	594,34	65x25	179,53	
W 1.1/2-6h.	3	38,10	33,50	150x50x24,0	715,56	75x30	272,90	
W 1.5/8-5h.	3	41,27	46,50	150x56x24,0	996,00	75x30	339,81	
W 1.3/4-5h.	3	44,45	39,00	160x58x29,0	1.225,84	90x36	427,66	
W 1.7/8-4,5h.	3	47,62	42,00	180x65x29,0	1.583,24	90x36	467,95	
W 2" - 4,5h.	3	50,80	44,50	180x65x32,0	1.662,13	90x36	490,41	
W 2.1/4-4h.	3	57,15	50,00	200x85x35,0	2.754,08	105x36		
W 2.1/2-4h.	3	63,50	56,50	220x85x39,0	3.350,38	120x36		
W 2.3/4-3,5h.	3	69,85	62,00	250x90x44,0	4.783,95	120x36		
W 3" - 3,5h.	3	76,20	68,00	250x90x44,0	5.534,50	140x36		

Icon	Uds.	D1 mm	Ø	L1 x L2 x mm	M0		C5	
					€	Ø x L3 mm	€	€
BSF 3/16-32h.	2	4,76	4,0	50x19x4,9	89,99	20x7	45,09	
BSF 1/4-26h.	2	6,35	5,2	50x20x4,9	50,26	20x7	49,93	
BSF 5/16-22h.	2	7,94	6,6	56x20x4,9	58,61	25x9	50,50	
BSF 3/8-20h.	2	9,52	8,1	63x22x5,5	67,83	30x11	97,01	
BSF 7/16-18h.	2	11,11	9,5	70x22x6,2	81,39	30x11	96,11	
BSF 1/2-16h.	2	12,70	11,0	75x25x7,0	92,08	38x10	83,87	
BSF 9/16-16h.	2	14,29	12,5	80x26x9,0	110,37	38x10	88,51	
BSF 5/8-14h.	2	15,88	14,0	80x26x9,0	144,44	45x14	137,98	
BSF 3/4-12h.	2	19,05	16,5	95x33x11,0	220,77	45x14	139,26	
BSF 7/8-11h.	2	22,23	19,5	100x33x14,5	263,50	55x22	186,75	
BSF 1" - 10h.	2	25,40	22,5	110x40x14,5	369,88	55x22	184,68	
BSF 1.1/8-9h.	2	28,57	25,5	110x40x16,0	834,60			
BSF 1.1/4-9h.	2	31,75	28,5	125x46x18,0	952,85			
BSF 1.1/2-8h.	2	38,10	34,5	150x55x22,0	1.452,21			

BSW **INOX** **TiN**

Icon	Uds.	L1 x L2 x mm	M0T		C5T	
			€	Ø x L3 mm	€	€
W 3/16-24 h.	3	50 x 19 x 4,90	62,70	25x9	62,67	
W 1/4-20 h.	3	50 x 20 x 4,90	70,18	25x9	63,82	
W 5/16-18 h.	3	56 x 20 x 4,90	76,90	25x9	66,34	
W 3/8-16 h.	3	63 x 22 x 5,50	90,51	38x10	78,42	
W 1/2-12 h.	3	75 x 25 x 7,00	127,72	38x14	105,36	



* Consulte o preço dos jogos de machos e caçonetes à esquerda disponíveis na Pag.188

MACHOS E CAÇONETES HSS PARA ROSCAGEM MANUAL

NPTF

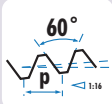

Rosca AMERICANA
Rosca Cônica estanque

Ref. MO

HSS

Ref. C5

HSS

DIN 223

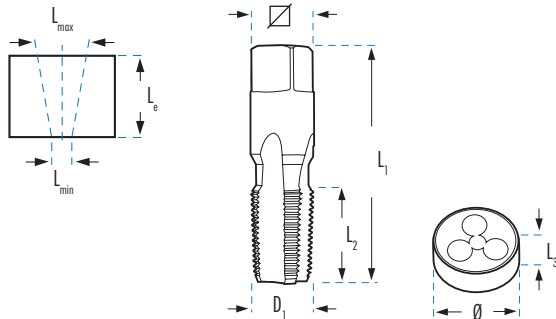

Uds.	D1 mm	Ø	L min x L max mm	Le mm	L1 x L2 x mm	MO		C5	
						€	Ø x L3 mm	€	
NPTF 1/8-27 h.	1	10,22	8,5	8,30 x 8,76	12,0	54 x 19 x 8,0	100,75	38 x 10	220,02
NPTF 1/4-18 h.	1	13,58	11,0	10,70 x 11,40	17,5	62 x 27 x 11,0	141,21	38 x 15	220,02
NPTF 3/8-18 h.	1	17,02	14,5	14,20 x 14,84	17,6	65 x 27 x 13,0	194,93	45 x 14	287,28
NPTF 1/2-14 h.	1	21,21	17,8	17,40 x 18,33	22,8	80 x 35 x 13,0	272,58	45 x 20	287,28
NPTF 3/4-14 h.	1	26,56	23,0	22,80 x 23,68	23,0	83 x 35 x 17,0	416,66	55 x 22	547,53
NPTF 1"-11,5 h.	1	33,19	29,0	28,60 x 29,72	27,4	110 x 38 x 20,0	554,99		

NPT

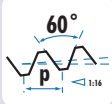

Rosca AMERICANA
Rosca cônica não estanque

Ref. MO

HSS

Ref. C5

HSS

DIN 223

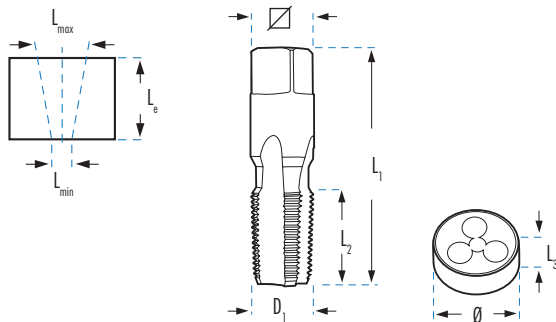

Uds.	D1 mm	Ø	L min x L max mm	Le mm	L1 x L2 x mm	MO		C5		
						€	Ø x L3 mm	€		
NPT 1/16-27 h.	1	7,89	6,20	EMNPT1/16	6,00 x 6,38	12,0	54 x 18 x 6,0	38,25	25 x 9	126,47
NPT 1/8-27 h.	1	10,24	8,50	EMNPT1/8	8,30 x 8,73	12,0	65 x 19 x 5,5	38,25	30 x 11	93,51
NPT 1/4-18 h.	1	13,62	11,00	EMNPT1/4	10,70 x 11,35	17,5	62 x 27 x 11,0	53,67	38 x 14	93,51
NPT 3/8-18 h.	1	17,05	14,50	EMNPT3/8	14,20 x 14,80	17,6	65 x 27 x 13,0	74,07	45 x 18	122,08
NPT 1/2-14 h.	1	21,23	17,80	EMNPT1/2	17,40 x 18,32	22,8	80 x 35 x 13,0	103,57	45 x 18	122,08
NPT 3/4-14 h.	1	26,57	23,00	-	22,80 x 23,66	23,0	83 x 35 x 17,0	158,33	55 x 22	223,32
NPT 1"-11,5 h.	1	33,23	29,00	-	28,60 x 29,69	27,4	95 x 44 x 21,0	176,34	65 x 25	268,47
NPT 1.1/4-11,5 h.	1	41,98	37,50	-	37,40 x 38,45	28,1	125 x 33 x 24,0	289,12	75 x 26	333,62
NPT 1.1/2-11,5 h.	1	48,05	44,00	-	43,40 x 44,52	28,4	140 x 33 x 29,0	439,33	90 x 27	465,46
NPT 2"-11,5 h.	1	60,09	56,00	-	55,50 x 56,56	28,4	160 x 33 x 35,0	685,88	105 x 36	648,03
NPT 2.1/2"-8h.	1	73,03	67,00	-	68,68 x 69,08	28,9	200 x 45 x 39,0	838,07		
NPT 3"-8h.	1	88,90	82,00	-	84,45 x 84,86	30,5	220 x 48 x 39,0	1.178,01		

* Veja mandril previo pag.137.

MACHOS E CAÇONETES HSS PARA ROSCAGEM MANUAL

PG

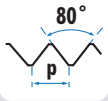

Ref. M0

HSS

DIN
40430

Ref. C5

HSS

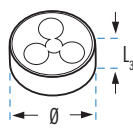
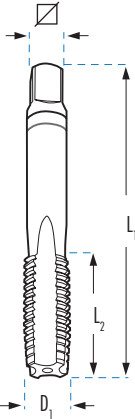
DIN
223

	Uds.	D1 mm	Ø	L1 x L2 x mm	M0		C5	
					€	Ø x L3 mm	€	
Pg 7	20h.	1	12,5	11,50	70x20x7,0	36,68	38x10	67,44
Pg 9	18h.	1	15,2	14,00	70x20x9,0	46,63	38x10	67,44
Pg 11	18h.	1	18,6	17,25	80x22x11,0	64,75	45x14	84,44
Pg 13,5	18h.	1	20,4	19,00	80x22x12,0	71,00	45x14	84,44
Pg 16	18h.	1	22,5	21,25	80x22x14,5	85,27	55x16	108,93
Pg 21	16h.	1	28,3	27,00	90x22x18,0	125,39	65x18	154,84
Pg 29	16h.	1	37,0	35,50	100x25x22,0	248,98	65x18	154,84
Pg 36	16h.	1	47,0	45,50	140x32x29,0	408,60	90x22	396,87
Pg 42	16h.	1	54,0	52,50	140x36x32,0	485,24	105x22	396,87
Pg 48	16h.	1	59,3	58,00	160x36x35,0	611,98	105x22	526,29

NPSF

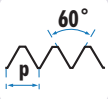
Rosca AMERICANA
Rosca Cilíndrica estanque

Ref. M0

HSS

Ref. C5

HSS

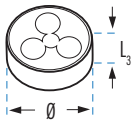
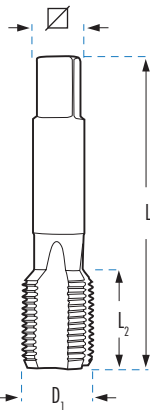
DIN
223

	Uds.	D1 mm	Ø	L1 x L2 x mm	M0		C5	
					€	Ø x L3 mm	€	
NPSF 1/8-27 h.	1	10,05	8,75	63x18x5,5	151,72	38x10	264,30	
NPSF 1/4-18 h.	1	13,35	11,30	70x20x9,0	219,24	38x10	264,30	
NPSF 3/8-18 h.	1	16,78	14,70	70x20x9,0	303,25	45x14	336,22	
NPSF 1/2-14 h.	1	20,87	18,20	80x22x12,0	396,43	45x14	336,22	
NPSF 3/4-14 h.	1	26,23	23,50	90x22x16,0	603,18	55x16	726,76	

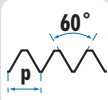
NPS
(M)Rosca AMERICANA
Rosca Cilíndrica não estanque

Ref. M0

HSS

Ref. C5

HSS

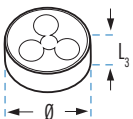
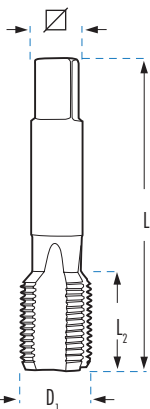
DIN
223

	Uds.	D1 mm	Ø	L1 x L2 x mm	M0		C5	
					€	Ø x L3 mm	€	
NPS 1/8-27 h.	1	10,20	8,9	63x18x5,5	125,71	38x10	220,19	
NPS 1/4-18 h.	1	13,60	11,7	70x20x9,0	100,04	38x10	220,19	
NPS 3/8-18 h.	1	17,00	15,0	70x20x9,0	138,37	45x14	280,17	
NPS 1/2-14 h.	1	21,20	18,6	80x22x12,0	180,86	45x14	280,17	
NPS 3/4-14 h.	1	26,55	24,0	90x22x16,0	262,64	55x16	555,02	
NPS 1"-11,5 h.	1	33,20	30,0	100x25x20,0	367,24	65x18	559,34	

JOGOS DE MACHOS E CAÇONETES HSS PARA ROSCAGEM MANUAL

BSPT

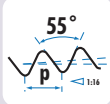

Ref. MO

HSS

DIN 5157

Ref. C5

HSS

DIN 223

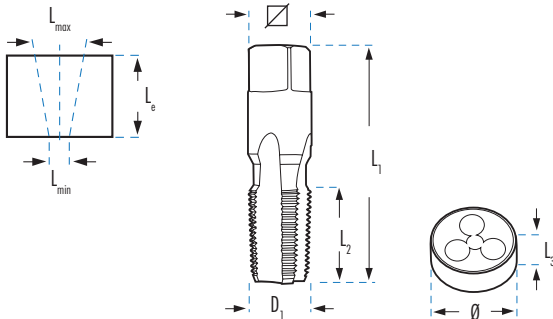

Icon	Uds.	D1 mm	Ø	L min x L max mm	L _e mm	L1 x L2 x L3 mm	MO		C5	
							€	Ø x L3 mm	€	
	1	9,73	8,30	8,00 x 8,50	10,1	65 x 19 x 5,5	34,25	30 x 11	102,09	
	1	13,16	11,00	10,70 x 11,35	15,0	70 x 25 x 9,0	48,26	38 x 14	102,09	
	1	16,66	14,50	14,15 x 14,25	15,4	70 x 25 x 9,0	67,01	45 x 16	132,96	
	1	20,95	18,10	17,60 x 18,50	20,5	80 x 31 x 12,0	93,83	55 x 22	132,96	
	1	22,91	20,00	19,50 x 20,40	22,4	80 x 36 x 14,5	164,55	55 x 19	277,45	
	1	26,44	23,50	23,00 x 24,00	21,8	85 x 33 x 16,0	153,11	55 x 22	251,09	
	1	30,20	27,25	26,65 x 28,75	24,0	100 x 36 x 18,0	290,16	65 x 22	362,48	
	1	33,25	29,60	29,00 x 30,20	26,0	110 x 38 x 20,0	242,48	65 x 25	289,96	

BA

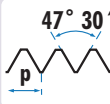

Ref. MO

HSS

DIN 352

Ref. C5

HSS

DIN 223

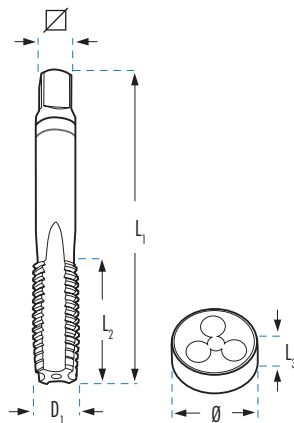

Icon	Uds.	D1 mm	Ø	L1 x L2 x L3 mm	MO		C5	
					€	Ø x L3 mm	€	
	1,00	3	6,0	5,1	50 x 18 x 4,9	213,39	20 x 5	166,83
	0,90	3	5,3	4,5	50 x 18 x 4,9	213,39	20 x 5	166,83
	0,81	3	4,7	4,0	50 x 17 x 4,9	213,39	20 x 5	166,83
	0,73	3	4,1	3,4	45 x 14 x 3,4	229,31	20 x 5	166,83
	0,66	3	3,6	3,0	45 x 14 x 3,0	229,31	20 x 5	166,83
	0,59	3	3,2	2,6	45 x 14 x 3,0	273,99	20 x 5	166,83
	0,53	3	2,8	2,3	40 x 12 x 2,7	273,99	20 x 5	166,83
	0,48	3	2,5	2,0	40 x 10 x 2,1	301,23	20 x 5	166,83
	0,43	3	2,2	1,8	36 x 10 x 2,1	301,23	20 x 5	166,83

JOGOS DE MACHOS E CAÇONETES HSS PARA ROSCAGEM MANUAL

UNx8

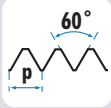

Rosca AMERICANA

Ref. MO

HSS

DIN
2181TOL
2B

Ref. C5

HSS

DIN
223TOL
2a

UN	Uds.	D1 mm	Ø	L1 x L2 x mm	MO		C5	
					€	Ø x L3 mm	€	
UN 1"1/8-8h.	2	28,57	25,40	138x65x17,0	402,39	65x25	440,73	
UN 1"1/4-8h.	2	31,75	28,50	146x65x19,5	521,83	65x25	440,73	
UN 1"3/8-8h.	2	34,92	31,75	154x76x21,0	649,01	65x25	438,79	
UN 1"1/2-8h.	2	38,10	35,00	162x76x23,5	742,74	75x30	496,75	
UN 1"5/8-8h.	2	41,27	38,10	170x80x25,0	923,43	75x30	519,95	
UN 1"3/4-8h.	2	44,45	41,25	178x81x27,0	1.150,84	90x36	693,29	
UN 1"7/8-8h.	2	47,62	44,45	186x90x29,0	1.435,74	90x36	741,81	
UN 2"-8h.	2	50,80	47,63	194x90x31,5	1.364,97	90x36	751,06	
UN 2"1/4-8h.	2	57,15	54,00	208x90x36,0				
UN 2"1/2-8h.	2	63,50	60,35	220x100x36,0				
UN 2"3/4-8h.	2	69,85	66,70	234x104x39,0				
UN 3"-8h.	2	76,20	73,05	248x115x49,0				

UNEF

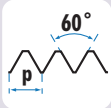

Rosca AMERICANA

Ref. MO

HSS

DIN
2181TOL
2B

Ref. C5

HSS

DIN
223TOL
2a

UNEF	Uds.	D1 mm	Ø	L1 x L2 x mm	MO		C5	
					€	Ø x L3 mm	€	
UNEF 1/4-32h.	2	6,35	5,55	65x28x4,9	108,15	20x7	109,81	
UNEF 5/16-32h.	2	7,94	7,15	70x30x6,0	120,83	25x9	109,81	
UNEF 3/8-32h.	2	9,52	8,70	75x33x7,0	138,28	30x11	170,51	
UNEF 7/16-28h.	2	11,11	10,20	81x38x6,0	176,02	30x11	170,51	
UNEF 1/2-28h.	2	12,70	11,80	86x44x7,0	198,89	38x10	170,51	
UNEF 9/16-24h.	2	14,29	13,20	92x44x8,0	162,59	38x10	170,51	
UNEF 5/8-24h.	2	15,87	14,80	93x47x9,0	167,47	45x14	273,30	
UNEF 3/4-20h.	2	19,05	17,80	108x52x11,0	184,31	45x14	273,30	
UNEF 7/8-20h.	2	22,22	20,95	120x58x13,0	279,71	55x16	325,10	
UNEF 1"-20h.	2	25,40	24,20	130x65x15,0	287,70	55x16	334,01	

JOGOS DE MACHOS E CAÇONETES PARA ROSCAGEM MANUAL APLICAÇÕES ESPECIAIS



Ref. MOMD

HSSCo
5%

DIN
352

OX



ESPECIAL MATERIAIS DUROS
(≤ 1100 N/mm²=40HRc)

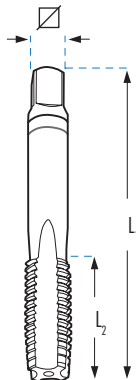

		MOMD		
	Uds.		L ₁ x L ₂ x mm	€
M 3 x 0,50	3	2,50	40 x 11 x 2,7	39,47
M 4 x 0,70	3	3,30	45 x 13 x 3,4	39,47
M 5 x 0,80	3	4,20	50 x 17 x 4,9	40,75
M 6 x 1,00	3	5,00	50 x 19 x 4,9	41,95
M 8 x 1,25	3	6,80	56 x 20 x 4,9	47,70
M 10 x 1,50	3	8,50	70 x 22 x 5,5	61,22
M 12 x 1,75	3	10,20	75 x 24 x 7,0	87,66
M 14 x 2,00	3	12,00	80 x 26 x 9,0	103,76
M 16 x 2,00	3	14,00	80 x 27 x 9,0	137,87
M 18 x 2,50	3	15,50	95 x 30 x 11,0	212,04
M 20 x 2,50	3	17,50	95 x 32 x 12,0	235,41

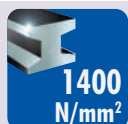

Ref. MOC

HSS
PM

TiAlSiN



ESPECIAL MATERIAIS MUITO DUROS
(≤ 1400 N/mm²=44HRc)

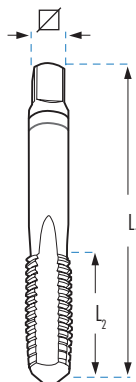

		MOC		
	Uds.		L ₁ x L ₂ x mm	€
M 3 x 0,50	3	2,50	40 x 11 x 2,7	85,89
M 4 x 0,70	3	3,30	45 x 13 x 3,4	92,67
M 5 x 0,80	3	4,20	50 x 17 x 4,9	93,83
M 6 x 1,00	3	5,00	50 x 19 x 4,9	93,83
M 8 x 1,25	3	6,80	56 x 20 x 4,9	105,76
M 10 x 1,50	3	8,50	70 x 22 x 5,5	130,73
M 12 x 1,75	3	10,20	75 x 24 x 7,0	158,91
M 14 x 2,00	3	12,00	80 x 26 x 9,0	190,66
M 16 x 2,00	3	14,00	80 x 27 x 9,0	233,64
M 18 x 2,50	3	15,50	95 x 30 x 11,0	323,93
M 20 x 2,50	3	17,50	95 x 32 x 12,0	356,52

AI

Ref. MOAL

HSS

BRILHANTE



ESPECIAL ALUMÍNIO

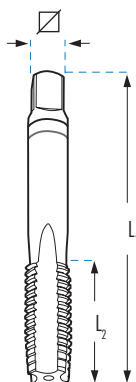

		MOAL		
	Uds.		L ₁ x L ₂ x mm	€
M 3 x 0,50	3	2,50	40 x 11 x 2,7	30,74
M 4 x 0,70	3	3,30	45 x 13 x 3,4	29,84
M 5 x 0,80	3	4,20	50 x 17 x 4,9	31,62
M 6 x 1,00	3	5,00	50 x 19 x 4,9	31,62
M 8 x 1,25	3	6,80	56 x 20 x 4,9	38,81
M 10 x 1,50	3	8,50	70 x 22 x 5,5	47,39
M 12 x 1,75	3	10,20	75 x 24 x 7,0	66,72
M 14 x 2,00	3	12,00	80 x 26 x 9,0	76,67
M 16 x 2,00	3	14,00	80 x 27 x 9,0	108,83
M 18 x 2,50	3	15,50	95 x 30 x 11,0	144,24
M 20 x 2,50	3	17,50	95 x 32 x 12,0	162,61

JOGOS DE MACHOS E CAÇONETES PARA ROSCAGEM MANUAL DE INOXIDÁVEL

M

INOX

Ref. MOT
Ref. MOXDIN
352TOL
6H

TiN

Ref. C5T
Ref. C5XDIN
223TOL
6g

OX

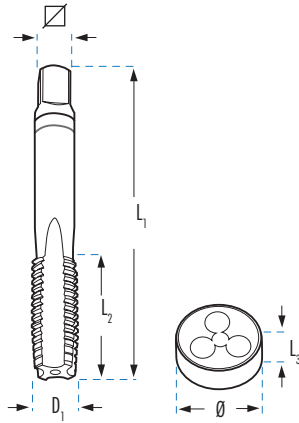

		Uds.	L1 x L2 x L3 mm	MOT	C5T	MOX	C5X	Ø x L3 mm
				HSS TiN	HSS TiN	HSSCo OX	HSSCo OX	
				€	€	€	€	
M	3 x 0,50	3	40 x 11 x 2,70	44,01	64,71	40,59	35,15	20 x 5
M	4 x 0,70	3	45 x 13 x 3,40	46,24	64,71	40,59	35,15	20 x 5
M	5 x 0,80	3	50 x 16 x 4,90	49,06	64,71	42,26	36,85	20 x 7
M	6 x 1,00	3	50 x 19 x 4,90	49,06	64,71	42,13	37,37	20 x 7
M	8 x 1,00	2	50 x 19 x 4,90	43,13				
M	8 x 1,25	3	56 x 22 x 4,90	56,58	66,34	49,03	40,53	25 x 9
M	10 x 1,00	2	63 x 18 x 5,50	49,76				
M	10 x 1,50	3	70 x 24 x 5,50	75,35	87,10	63,08	51,43	30 x 11
M	12 x 1,50	2	70 x 20 x 7,00	63,36				
M	12 x 1,75	3	75 x 29 x 7,00	87,43	96,57	90,33	54,33	38 x 14
M	14 x 1,50	2	70 x 20 x 9,00	76,08				
M	14 x 2,00	3	80 x 30 x 9,00	105,73	96,57	100,03	54,33	38 x 14
M	16 x 2,00	3	80 x 32 x 9,00	132,78	119,01	137,09	72,94	45 x 18
M	18 x 2,50	3	95 x 40 x 11,00	164,59		187,23		
M	20 x 2,50	3	95 x 40 x 12,00	170,68		207,82		
M	22 x 2,50	3	100 x 40 x 14,50	215,91				
M	24 x 3,00	3	110 x 50 x 14,50	260,17				

M

CAÇONETES SEXTAVADOS HSS PARA ROSCAGEM MANUAL

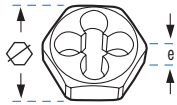

M **HSS** **DIN 382**

		C5HM	
			€
M 3 x 0,35		18 x 5	41,87
M 3 x 0,50		19 x 5	41,87
M 3,5 x 0,60		18 x 5	41,87
M 4 x 0,50		18 x 5	41,87
M 4 x 0,70		19 x 5	41,87
M 5 x 0,50		18 x 5	41,87
M 5 x 0,75		18 x 5	41,87
M 5 x 0,80		19 x 7	41,87
M 6 x 0,75		18 x 7	41,87
M 6 x 1,00		19 x 7	41,87
M 7 x 0,75		21 x 9	44,51
M 7 x 1,00		21 x 9	44,51
M 8 x 0,75		21 x 9	44,51
M 8 x 1,00		21 x 9	44,51
M 8 x 1,25		22 x 9	44,51
M 9 x 0,75		21 x 9	52,39
M 9 x 1,00		21 x 9	52,39
M 9 x 1,25		22 x 9	52,39
M 10 x 1,00		27 x 11	52,39
M 10 x 1,25		27 x 11	52,39
M 10 x 1,50		27 x 11	52,39
M 11 x 1,00		27 x 11	87,29
M 11 x 1,50		27 x 11	87,29
M 12 x 1,25		36 x 10	87,29
M 12 x 1,50		36 x 10	87,29
M 12 x 1,75		36 x 10	73,34
M 14 x 1,25		36 x 14	99,19
M 14 x 1,50		36 x 10	99,19
M 14 x 2,00		36 x 10	73,34
M 15 x 1,00		36 x 14	115,05
M 15 x 1,50		41 x 14	115,05
M 16 x 1,00		41 x 14	115,05
M 16 x 1,50		41 x 14	115,05

		C5HM	
			€
M 16 x 2,00		41 x 18	115,05
M 18 x 1,00		41 x 14	115,05
M 18 x 1,50		41 x 14	115,05
M 18 x 2,50		41 x 18	115,05
M 20 x 1,00		41 x 14	115,05
M 20 x 1,50		41 x 14	115,05
M 20 x 2,00		41 x 18	115,05
M 20 x 2,50		41 x 18	115,05
M 22 x 1,00		50 x 16	145,47
M 22 x 1,50		50 x 16	145,47
M 22 x 2,00		50 x 16	145,47
M 22 x 2,50		50 x 16	145,47
M 24 x 1,00		50 x 16	177,17
M 24 x 1,50		50 x 16	177,17
M 24 x 2,00		50 x 16	177,17
M 24 x 3,00		50 x 22	145,47
M 27 x 1,50		60 x 18	196,69
M 27 x 2,00		60 x 18	196,69
M 27 x 3,00		60 x 25	163,90
M 30 x 1,00		60 x 18	196,69
M 30 x 1,50		60 x 18	196,69
M 30 x 2,00		60 x 18	196,69
M 30 x 3,00		60 x 18	196,69
M 30 x 3,50		60 x 25	163,90
M 33 x 1,50		60 x 18	220,23
M 33 x 2,00		60 x 18	220,23
M 33 x 3,50		60 x 25	183,54
M 35 x 1,50		60 x 18	227,04
M 36 x 1,50		60 x 18	227,04
M 36 x 2,00		60 x 18	227,04
M 36 x 3,00		60 x 18	227,04
M 36 x 4,00		60 x 25	189,20

BSP (GAS) **HSS** **DIN 382**

		C5HG	
			€
G 1/8 x 28h.		27 x 11	92,20
G 1/4 x 19h.		36 x 10	92,20
G 3/8 x 19h.		41 x 14	115,30
G 1/2 x 14h.		41 x 14	115,30
G 5/8 x 14h.		50 x 16	271,47
G 3/4 x 14h.		50 x 16	271,47
G 7/8 x 14h.		60 x 18	273,88
G 1" x 11h.		60 x 18	273,88
G1.1/4 x 11h.		70 x 20	365,18
G1.1/2 x 11h.		85 x 22	616,07
G 2" x 11h.		100 x 22	927,05

UNC **HSS** **DIN 382**

		C5HNC	
			€
UNC 1/4-20h		18 x 7	38,18
UNC 5/16-18h		21 x 9	47,51
UNC 3/8-16h		27 x 11	57,35
UNC 7/16-14h		27 x 11	84,64
UNC 1/2-13h		36 x 14	84,95
UNC 9/16-12h		36 x 14	101,52
UNC 5/8-11h		41 x 18	78,65
UNC 3/4-10h		41 x 18	125,11
UNC 7/8-9h		50 x 22	177,55
UNC 1"-8h		50 x 22	177,55
UNC 1.1/8-7h		60 x 25	234,75
UNC 1.1/4-7h		60 x 25	234,75

UNF **HSS** **DIN 382**

		C5HNF	
			€
UNF 1/4-28h.		18 x 7	40,47
UNF 5/16-24h.		21 x 9	50,60
UNF 3/8-24h.		27 x 11	60,88
UNF 7/16-20h.		27 x 11	89,70
UNF 1/2-20h.		36 x 10	91,08
UNF 9/16-18h.		36 x 10	101,52
UNF 5/8-18h.		41 x 14	126,65
UNF 3/4-16h.		41 x 14	132,63
UNF 7/8-14h.		50 x 16	167,75
UNF 1"-12h.		50 x 16	175,84
UNS 1"-14h.		50 x 16	175,84
UNF 1.1/8-12h.		60 x 18	234,75
UNF 1.1/4-12h.		60 x 18	234,75

BSW **HSS** **DIN 382**

		C5HW	
			€
BSW 1/8 x 40h.		19 x 5	52,39
BSW 3/16 x 24h.		19 x 7	52,39
BSW 1/4 x 20h.		19 x 7	52,39
BSW 5/16 x 18h.		22 x 9	54,99
BSW 3/8 x 16h.		27 x 11	65,47
BSW 7/16 x 14h.		27 x 11	65,47
BSW 1/2 x 12h.		36 x 14	78,59

		C5HW	
			€
BSW 9/16 x 12h.		36 x 14	78,59
BSW 5/8 x 11h.		41 x 18	116,13
BSW 3/4 x 10h.		41 x 18	116,13
BSW 7/8 x 9h.		50 x 22	170,21
BSW 1" x 8h.		50 x 22	170,21
BSW 1.1/8 x 7h.		60 x 25	293,37

JOGOS DE MACHOS E CAÇONETES HSS PARA ROSCAGEM MANUAL, ROSCA ESQUERDA

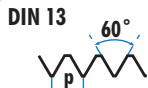
M
MF

Ref. MOI

HSS

DIN
352DIN
2181TOL
6H

Ref. CSI

HSS

DIN
223TOL
6g

Para materiais até 38HRC



ESQUERDA

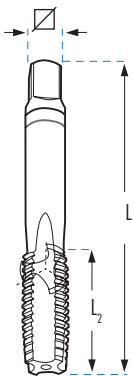

Uds.

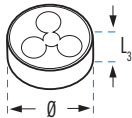

UNC



	Uds.	D1 mm	Ø	L1 x L2 x mm	MOI		CSI	
					€	Ø x L3 mm	€	
UNC 1/4-20h.	3	6,35	5,10	50x19x4,9	99,75	20x7	85,37	
UNC 5/16-18h.	3	7,94	6,60	56x22x4,9	113,24	25x9	87,59	
UNC 3/8-16h.	3	9,52	8,00	70x24x5,5	128,83	30x11	121,79	
UNC 1/2-13h.	3	12,70	10,75	75x29x7,0	193,02	38x14	125,19	
UNC 5/8-11h.	3	15,87	13,50	80x32x9,0	314,27	45x18	177,59	
UNC 3/4-10h.	3	19,05	16,50	95x40x11,0	428,21	45x18	177,59	
UNC 1"-8h.	3	25,40	22,25	110x50x14,5	711,81	55x22	238,38	

UNF



	Uds.	D1 mm	Ø	L1 x L2 x mm	MOI		CSI	
					€	Ø x L3 mm	€	
UNF 1/4-28h.	2	6,35	5,50	50x14x4,9	66,21	25x9	79,97	
UNF 5/16-24h.	2	7,94	6,90	56x22x4,9	70,88	25x9	89,26	
UNF 3/8-24h.	2	9,52	8,50	63x20x5,5	81,84	38x10	121,79	
UNF 1/2-20h.	2	12,70	11,50	70x22x7,0	111,12	38x10	130,17	
UNF 5/8-18h.	2	15,87	14,50	70x22x9,0	187,05	45x14	177,59	
UNF 3/4-16h.	2	19,05	17,50	80x22x11,0	251,24	45x14	177,59	
UNS 1"-14h.	2	25,40	23,60	90x22x14,5	474,27	55x16	259,02	

BSP
(GAS)

	Uds.	D1 mm	Ø	L1 x L2 x mm	MOI		CSI	
					€	Ø x L3 mm	€	
G 1/8-28h.	2	9,73	8,80	63 x 20 x 5,5	74,02	38x10	108,89	
G 1/4-19h.	2	13,16	11,80	70 x 22 x 9,0	104,32	38x10	108,31	
G 3/8-19h.	2	16,66	15,25	70 x 22 x 9,0	130,95	45x14	143,46	
G 1/2-14h.	2	20,95	19,00	80 x 22 x 12,0	183,67	45x14	143,46	
G 5/8-14h.	2	22,91	21,00	80 x 22 x 14,5	235,00	55x16	199,02	
G 3/4-14h.	2	26,44	24,50	90 x 22 x 16,0	286,69	55x16	259,07	
G 1"-11h.	2	33,25	30,75	100 x 25 x 20,0	454,50	65x18	311,39	
G 1.1/4-11h.	2	41,91	39,50	125 x 40 x 24,0	790,40	75x20	431,41	

BSW



	Uds.	D1 mm	Ø	L1 x L2 x mm	MOI		CSI	
					€	Ø x L3 mm	€	
W 1/8-40h.	3	3,17	2,55	40x14x2,7	65,67	25x9	68,54	
W 1/4-20h.	3	6,35	5,10	50x20x4,9	73,97	25x9	69,92	
W 5/16-18h.	3	7,94	6,50	56x20x4,9	90,35	25x9	72,92	
W 3/8-16h.	3	9,52	7,90	63x22x5,5	99,27	38x10	105,53	
W 5/8-11h.	3	15,87	13,40	80x27x9,0	223,72	45x18	150,61	
W 3/4-10h.	3	19,05	16,50	95x32x11,0	318,48	45x18	150,83	
W 7/8-9h.	3	22,22	19,25	100x32x14,5	434,95	55x22	221,78	
W 1"-8h.	3	25,40	21,75	110x36x14,5	533,03	55x22	223,80	

	Uds.	Ø	L1 x L2 x mm	MOI		CSI	
				€	Ø x L3 mm	€	
M 2x0,40	3	1,60	36x9,0x2,1	81,02	16x5	68,21	
M 3x0,50	3	2,50	40x11,0x2,7	45,48	25x9	62,03	
M 4x0,70	3	3,30	45x13,0x3,4	45,44	25x9	62,35	
M 5x0,80	3	4,20	50x16,0x4,9	48,57	25x9	61,99	
M 6x1,00	3	5,00	50x19x4,9	48,57	25x9	62,03	
M 7x1,00	3	6,00	50x19x4,9	59,18	25x9	65,12	
M 8x1,00	2	7,00	56x18x4,9	54,59	25x9	71,97	
M 8x1,25	3	6,80	56x22x4,9	59,12	25x9	65,81	
M 9x1,25	3	7,80	63x22x5,5	96,86	25x9	76,50	
M 10x1,50	3	8,50	70x24x5,5	72,90	38x10	88,10	
M 12x1,50	2	10,50	70x20x7,0	88,07	38x10	110,42	
M 12x1,75	3	10,20	75x29x7,0	102,57	38x14	95,72	
M 14x1,25	2	12,80	70x20x9,0	126,20	38x10	143,22	
M 14x2,00	3	12,00	80x30x9,0	113,46	38x14	94,77	
M 16x1,50	2	14,50	70x20x9,0	122,12	45x14	137,15	
M 16x2,00	3	14,00	80x32x9,0	162,35	45x18	128,50	
M 18x2,00	2	16,00	80x22x11,0	256,80	45x14	185,60	
M 18x2,50	3	15,50	95x40x11,0	214,26	45x18	128,56	
M 20x2,00	2	18,00	80x22x12,0	272,00	45x14	184,63	
M 20x2,50	3	17,50	95x40x12,0	240,36	45x18	126,55	
M 22x2,00	2	20,00	80x22x14,5	353,48	55x16	237,89	
M 22x2,50	3	19,50	100x40x14,5	320,17	55x22	190,16	
M 24x2,00	2	22,00	90x22x14,5	421,50	55x16	242,40	
M 24x3,00	3	21,00	110x50x14,5	381,88	55x22	190,16	
M 27x2,00	2	25,00	90x22x16,0	584,15	65x18	358,26	
M 27x3,00	3	24,00	110x50x16,0	482,91	65x25	288,44	
M 30x3,00	2	27,00	125x56x18,0	619,28	65x25	406,62	
M 30x3,50	3	26,50	125x50x18,0	621,30	65x25	289,17	
M 33x2,00	2	31,00	100x25x20,0	883,41	65x18	502,28	
M 33x3,50	3	29,50	125x50x20,0	780,16	65x25	294,71	
M 36x3,00	2	33,00	125x33x22,0	1.426,26	65x25	346,56	
M 36x4,00	3	32,00	150x53x22,0	1.004,41	65x25	300,47	
M 39x3,00	2	36,00	125x33x24,0	1.233,12	75x30	542,91	
M 39x4,00	3	35,00	150x53x24,0	1.123,87	75x30	457,02	

Consulte outras medidas disponíveis sob demanda.

MACHO Nº3 PARA ROSCAR A MÃO, ROSCA METRICA, ESQUERDA E DIREITA

**M
MF**

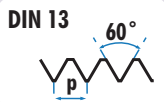

HSS

**DIN
352**

**TOL
6H**

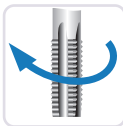

ESQUERDA

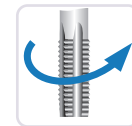

DIREITA

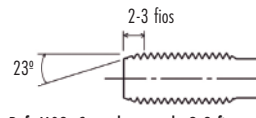

Ref. M03: Cone de entrada 2-3 fios

**D
CABO
FINO**

**DIN
352**

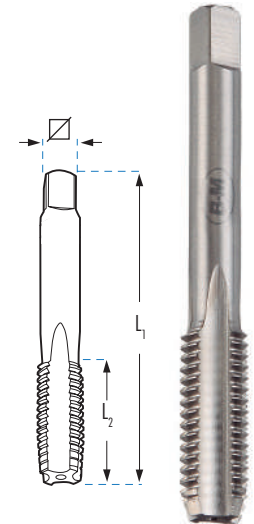

				M03I
		$L1 \times L2 \times D2 \times \nabla$ mm		€
M 3x0,50	2,50	D 40 x 11 x 3,50 x 2,70		15,16
M 4x0,70	3,30	D 45 x 13 x 4,50 x 3,40		15,15
M 5x0,80	4,20	D 50 x 16 x 6,00 x 4,90		16,19
M 6x1,00	5,00	D 50 x 19 x 6,00 x 4,90		16,19
M 7x1,00	6,00	D 50 x 19 x 6,00 x 4,90		19,73
M 8x1,25	6,75	D 56 x 22 x 6,00 x 4,90		19,71
M 10x1,50	8,50	D 70 x 24 x 7,00 x 5,50		24,30
M 12x1,75	10,20	D 75 x 29 x 9,00 x 7,00		34,19
M 14x2,00	12,00	D 80 x 30 x 11,00 x 9,00		37,82
M 16x2,00	14,00	D 80 x 32 x 12,00 x 9,00		54,12
M 18x2,50	15,50	D 95 x 40 x 14,00 x 11,00		71,42
M 20x2,50	17,50	D 95 x 40 x 16,00 x 12,00		80,12

Consulte outras medidas disponíveis sob demanda.

				M03
		$L1 \times L2 \times D2 \times \nabla$ mm		€
M 3x0,50	2,50	D 40 x 11 x 3,50 x 2,70		7,58
M 4x0,70	3,30	D 45 x 13 x 4,50 x 3,40		7,57
M 5x0,80	4,20	D 50 x 16 x 6,00 x 4,90		8,10
M 6x1,00	5,00	D 50 x 19 x 6,00 x 4,90		8,10
M 7x1,00	6,00	D 50 x 19 x 6,00 x 4,90		9,86
M 8x1,00	7,00	D 56 x 18 x 6,00 x 4,90		13,65
M 8x1,25	6,75	D 56 x 22 x 6,00 x 4,90		9,85
M 9x1,25	7,75	D 63 x 18 x 7,00 x 5,50		16,14
M 10x1,00	9,00	D 63 x 18 x 7,00 x 5,50		14,62
M 10x1,25	8,80	D 70 x 24 x 7,00 x 5,50		14,82
M 10x1,50	8,50	D 70 x 24 x 7,00 x 5,50		12,15
M 12x1,00	11,00	D 70 x 20 x 9,00 x 7,00		25,91
M 12x1,25	10,75	D 70 x 20 x 9,00 x 7,00		25,84
M 12x1,50	10,50	D 70 x 20 x 9,00 x 7,00		22,02
M 12x1,75	10,20	D 75 x 29 x 9,00 x 7,00		17,09
M 14x1,00	13,00	D 70 x 20 x 11,00 x 9,00		40,39
M 14x1,25	12,80	D 70 x 20 x 11,00 x 9,00		31,55
M 14x1,50	12,50	D 70 x 20 x 11,00 x 9,00		24,53
M 14x2,00	12,00	D 80 x 30 x 11,00 x 9,00		18,91
M 16x1,00	15,00	D 70 x 20 x 12,00 x 9,00		53,58
M 16x1,25	14,75	D 70 x 20 x 12,00 x 9,00		56,40
M 16x1,50	14,50	D 70 x 20 x 12,00 x 9,00		30,53
M 16x2,00	14,00	D 80 x 32 x 12,00 x 9,00		27,06
M 18x1,50	16,50	D 80 x 22 x 14,00 x 11,00		40,22
M 18x2,50	15,50	D 95 x 40 x 14,00 x 11,00		35,71
M 20x1,50	18,50	D 80 x 22 x 16,00 x 12,00		50,37
M 20x2,50	17,50	D 95 x 40 x 16,00 x 12,00		40,06
M 22x2,50	19,50	D 100 x 40 x 18,00 x 14,50		53,36
M 24x3,00	21,00	D 110 x 50 x 18,00 x 14,50		63,65
M 27x3,00	24,00	D 110 x 50 x 20,00 x 16,00		80,48
M 30x3,50	26,50	D 125 x 50 x 22,00 x 18,00		103,55

CONTA-FIOS PARA COMPROVAÇÃO DE PASSOS DE ROSCAS



TIPOS DE ROSCA	FAIXA DE PASSOS		GAM
	Métricos	Ingleses	€
GAM	Passos rosca métrica		12,27
GAMW	0,25 - 6,0	62h - 4h	22,23

CONJUNTO DE GUIAS PARA CAÇONETES M3-M12

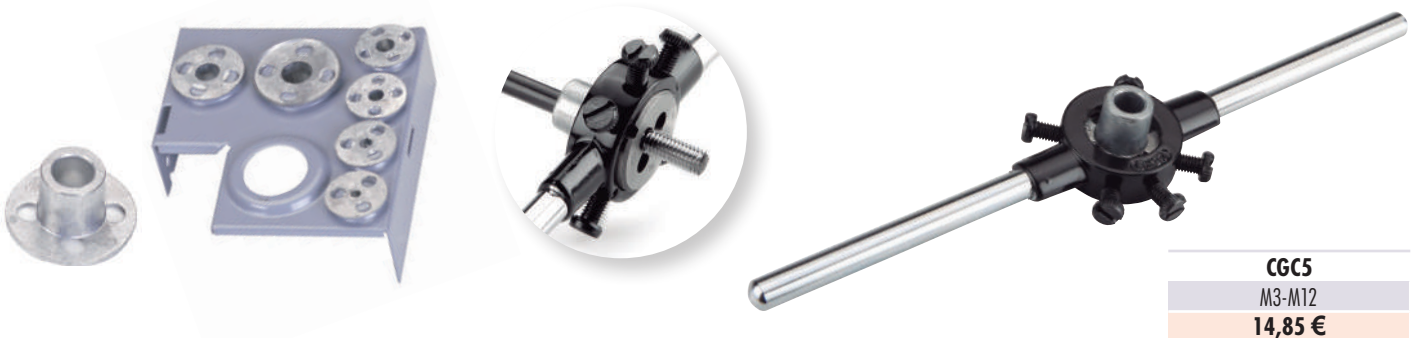

CGC5
M3-M12
14,85 €

EXTENSÃO DE MACHOS

DIN
377

DIN 10

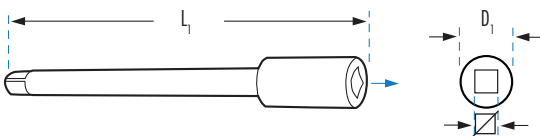

Mesma medida do quadrado nas zonas macho e fêmea.

	∅ x L1 mm	D1 mm	AL €
AL21	2,1 x 60	6,0	8,89
AL24	2,4 x 70	6,0	8,89
AL27	2,7 x 80	7,0	8,89
AL30	3,0 x 90	7,0	8,89
AL34	3,4 x 95	8,0	9,64
AL38	3,8 x 95	9,0	10,06
AL43	4,3 x 105	10,0	11,21
AL49	4,9 x 110	11,0	11,22
AL55	5,5 x 115	12,0	11,29
AL62	6,2 x 120	14,0	13,75
AL70	7,0 x 125	15,0	14,33
AL80	8,0 x 125	17,0	17,89
AL90	9,0 x 135	19,0	18,38

	∅ x L1 mm	D1 mm	AL €
AL100	10,0 x 140	21,0	25,39
AL110	11,0 x 150	23,0	25,74
AL120	12,0 x 160	25,0	27,72
AL130	13,0 x 165	27,0	43,36
AL145	14,5 x 175	29,0	43,97
AL160	16,0 x 185	30,0	46,53
AL180	18,0 x 195	33,0	53,01
AL200	20,0 x 220	36,0	70,71
AL220	22,0 x 220	40,0	103,34
AL240	24,0 x 235	42,0	158,27
AL260	26,0 x 245	45,0	167,12
AL290	29,0 x 260	55,0	192,82
AL320	32,0 x 280	55,0	237,36

DESANDADORES DE AÇO FORJADO

Máxima Resistência
150 kg/mm²

Ref. GAPRO

- Corpo de aço forjado
- Suporta esforços até 150 kg/mm²
- Máxima resistência e durabilidade

- Maior precisão e firmeza na amarração
- A sua rosca de precisão forma um conjunto sólido e robusto
- Cabo antidesslizante, maior aderência na oficina



GAPRO

Nº NORMA	Nº 0	Nº 1	Nº 1.1/2	Nº 2	Nº 3	Nº 4	Nº 5
	M1-M8 2,00-5,00	M1-M10 2,00-6,30	M1-M12 2,50-7,00	M1-M12 2,50-8,00	M5-M20 4,00-13,00	M5-M27 4,00-16,00	M9-M32 5,50-20,00
€	22,05	23,30	24,76	31,29	44,28	70,80	149,85

Ref. GA

- Corpo de liga de zinco
- Alta resistência e durabilidade
- Alta precisão e firmeza na amarração



GA

Nº NORMA	Nº 0	Nº 1	Nº 1.1/2	Nº 2	Nº 3	Nº 4	Nº 5	Nº 7	Nº 8
	M1-M8 1,50-5,00	M1-M10 2,00-7,00	M1-M12 2,00-8,00	M4-M12 2,50-10,00	M5-M20 3,50-14,00	M9-M27 4,00-15,00	M13-M32 5,50-19,00	M22-M52 14,00-34,00	M33-M64 16,00-40,00
€	18,53	19,59	20,81	26,29	37,20	59,50	125,93	248,77	406,43

DESANDADORES DE CAÇONETES PARA ROSCAGEM

Ref. VA

DIN 225



5

IMPORTANTE: no momento de fazer as suas encomendas de desandadores, indique a espessura que corresponda, conforme ao detalhe de espessuras indicadas na tabela de caçonetes.

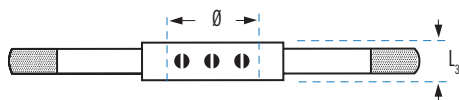

Ø x L3 mm	16x5	20x5	20x7	25x9	30x11	38x10	38x14	45x14	45x18	55x16	55x22	65x18	VA 65x25
€	10,29	11,39	11,39	13,00	15,75	20,59	20,56	25,28	25,46	32,67	34,22	46,81	46,81
Ø x L3 mm	75x20	75x30	90x22	90x36	105x22	105x36	120x22	120x36	130x25	130x36			
€	106,31	111,28	134,66	145,08	200,35	200,35	521,07	521,07	541,71	541,71			

Ref. VA

POLEGADAS



3



Ø mm	20,60	25,40	38,10	50,80	63,50	76,20	VA 88,90
POLEGADAS	13/16"	1"	1.1/2"	2"	2.1/2"	3"	3.1/2"
€	13,54	16,06	24,04	35,65	56,26	104,04	131,79

NOTA: os desandadores para caçonetes com Ø exteriores em polegadas estão em desuso.

DESANDADOR EM T COM ROQUETE

Ref. TC

TIPO
T

SERIE CURTA



	CAPACIDADE mm mín.-máx.	Para cabos de machos		L1 mm	PESO g	QUALIDADE	TC
		DIN	ISO				€
TC3B	2,6 - 5,5	M3 - 8	M3 - 6	85	180	1ª Qualidade	30,26
TC4B	4,6 - 8,0	M5 - 12	M6 - 12	110	300	1ª Qualidade	40,89
TC1B	2,6 - 5,5	M3 - 8	M3 - 6	85	180	2ª Qualidade	22,92
TC2B	4,6 - 8,0	M5 - 12	M6 - 12	110	300	2ª Qualidade	30,74

Ref. TL

TIPO
T

SERIE LONGA



	CAPACIDADE mm mín.-máx.	Para cabos de machos		L1 mm	PESO g	QUALIDADE	TL
		DIN	ISO				€
TL3	2,6 - 5,5	M3 - 8	M3 - 6	250	250	1ª Qualidade	46,03
TL4	4,6 - 8,0	M5 - 12	M6 - 12	300	440	1ª Qualidade	54,80
TL1	2,6 - 5,5	M3 - 10	M3 - 6	250	250	2ª Qualidade	36,35
TL2	4,6 - 8,0	M5 - 12	M6 - 12	300	440	2ª Qualidade	43,31

EXPOSITOR DE METACRILATO

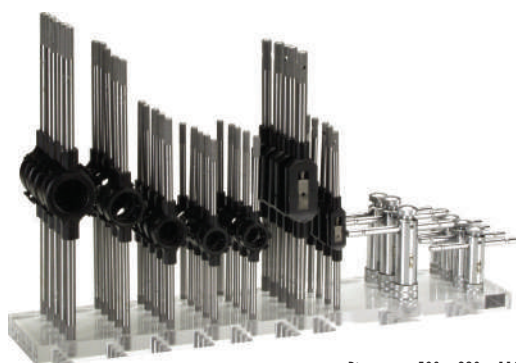

Dimensões: 500 x 320 x 110 mm

						GV-01	
	€	€	€	€	€	€	
GV-01	Nº 1 1/2 5	Nº 2 5	20 x 5 5	20 x 7 5	25 x 9 5	TC1 TC2 4 4	797,07
			30 x 11 5	38 x 14 5			

CONJUNTOS DE MACHOS E CAÇONETES HSS EM CAIXA METÁLICA



M3
M12

HSS



Ref. D624

CONTEÚDO

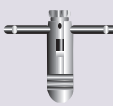
					Nº Peças	1ª Qualidade €	2ª Qualidade €
D624	M3 - M4 - M5 - M6 - M8 - M10 - M12	Nº 1.1/2	25 x 9	-	30	258,27	234,29

CONJUNTOS DE CAÇONETES HSS EM CAIXA METÁLICA



M3
M12

HSS



Ref. D671

CONTEÚDO

			Nº Peças	1ª Qualidade €	2ª Qualidade €		
D671	M3 - M4 - M5 - M6 - M8 - M10 - M12	20 x 5 30 x 11	20 x 7 38 x 14	25 x 9	12	254,76	215,79
D6711 (esq.)	 M3 - M4 - M5 - M6 - M8 - M10 - M12	20 x 5 30 x 11	20 x 7 38 x 14	25 x 9	12	458,57	388,41

CONJUNTOS DE MACHOS E CAÇONETES HSS E HSSCo EM CAIXA METÁLICA

M3
M12

HSS

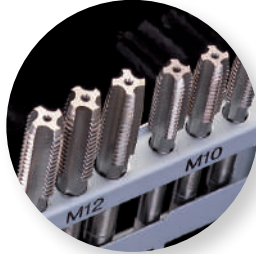
HSSCo
5%

Ref. D621



Ref. D655

CONTEÚDO

							Nº Peças	1ª Qualidade €	2ª Qualidade €
D621	M3 - M4 - M5 - M6 M8 - M10 - M12	2.5 / 3.3 / 4.2 / 5.0 6.8 / 8.5 / 10.2 mm	Nº 1 Nº 2	20 x 5 20 x 7 25 x 9 30 x 11 38 x 14		TC1	43	517,87	379,58
D652	M3 - M4 - M5 - M6 M8 - M10 - M12	2.5 / 3.3 / 4.2 / 5.0 6.8 / 8.5 / 10.2 mm	Nº 1 Nº 2	20 x 5 20 x 7 25 x 9 30 x 11 38 x 14		-	42	501,29	360,46
D662	M3-M4-M5-M6-M7 M8-M9-M10-M11-M12	-	Nº 1 Nº 2	20 x 5 20 x 7 25 x 9 30 x 11 38 x 14		TC1	48	771,48	678,57
D651	M3 - M4 - M5 - M6 M8 - M10 - M12	-	Nº 1 Nº 2	20 x 5 20 x 7 25 x 9 30 x 11 38 x 14		-	35	395,65	363,99
D655* (HSSCo)	M3 - M4 - M5 - M6 M8 - M10 - M12	2.5 / 3.3 / 4.2 / 5.0 6.8 / 8.5 / 10.2 mm	Nº 1 Nº 2	20 x 5 20 x 7 25 x 9 30 x 11 38 x 14		TC1	43	826,14	726,70
D621I (esq.)	M3 - M4 - M5 - M6 M8 - M10 - M12	2.5 / 3.3 / 4.2 / 5.0 6.8 / 8.5 / 10.2 mm	Nº 1 Nº 2	20 x 5 20 x 7 25 x 9 30 x 11 38 x 14		TC1	43	932,17	683,24

*

HSSCo
5%

CONJUNTOS DE MACHOS E CAÇONETES HSS E HSSCo EM CAIXA METÁLICA COM GUIAS PARA CAÇONETES

**M3
M12**



HSS

**HSSCo
5%**



Ref. D656



GUIAS



Ref. D657



GUIAS

CONTEÚDO

							Nº Peças	1ª Qualidade €	2ª Qualidade €
D656	M3 - M4 - M5 - M6 M8 - M10 - M12	2.5 / 3.3 / 4.2 / 5.0 6.8 / 8.5 / 10.2 mm	Nº 1 Nº 2	20 x 5 20 x 7 25 x 9 30 x 11 38 x 14	+ GUIAS	TC1	43	578,71	512,29
D657* (HSSCo)	M3 - M4 - M5 - M6 M8 - M10 - M12	2.5 / 3.3 / 4.2 / 5.0 6.8 / 8.5 / 10.2 mm	Nº 1 Nº 2	20 x 5 20 x 7 25 x 9 30 x 11 38 x 14		TC1	43	861,50	760,39

* **HSSCo 5%**

CONJUNTOS DE MACHOS E CAÇONETES HSS E HSSCo EM CAIXA METÁLICA

M3
M20M5
M20

HSS

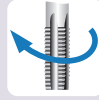
HSSCo
5%

Ref. D622



Ref. D623

CONTEÚDO

					Nº Peças	1ª Qualidade €	2ª Qualidade €
D622	M3 - M4 - M5 - M6 - M8 - M10 - M12 M14 - M16 - M18 - M20	Nº 1 Nº 3	20 x 5 20 x 7 25 x 9 30 x 11 38 x 14 45 x 18	TC1 TC2	54	885,75	695,91
D658	M3 - M4 - M5 - M6 - M8 - M10 - M12 M14 - M16 - M18 - M20	Nº 1 Nº 3	20 x 5 20 x 7 25 x 9 30 x 11 38 x 14 45 x 18	-	52	815,98	629,61
D6221 (esq.)	M3 - M4 - M5 - M6 - M8 - M10 - M12 M14 - M16 - M18 - M20	Nº 1 Nº 3	20 x 5 20 x 7 25 x 9 30 x 11 38 x 14 45 x 18	TC1 TC2	54	1594,35	1.252,64
D659* (HSSCo)	M3 - M4 - M5 - M6 - M8 - M10 - M12 M14 - M16 - M18 - M20	Nº 1 Nº 3	20 x 5 20 x 7 25 x 9 30 x 11 38 x 14 45 x 18	-	52	1839,88	1.618,36
D623	M5 - M6 - M8 - M10 - M12 M14 - M16 - M18 - M20	Nº 1 Nº 3	20 x 7 25 x 9 30 x 11 38 x 14 45 x 18	TC1 TC2	45	928,65	727,04
D663	M5 - M6 - M7 - M8 - M9 - M10 - M12 M14 - M16 - M18 - M20	Nº 1 Nº 3	20 x 7 25 x 9 30 x 11 38 x 14 45 x 18	-	51	1.238,09	1.113,64

*

HSSCo
5%

CONJUNTOS DE MACHOS E CAÇONETES HSS EM CAIXA METÁLICA

M1 M10
M5 M12
M3 M24
M5 M30
HSS



Ref. D628



Ref. D626

CONTEÚDO

					Nº Peças	1ª Qualidade €	2ª Qualidade €
D626	M1 - M1.2 - M1.4 - M1.7 - M2.0 - M2.3 M2.6 - M3 - M3.5 - M4 - M5 - M6 - M8 - M10	Nº 0 Nº 1	16 x 5 20 x 5 20 x 7 25 x 9 30 x 11	TC1	64	-	1.158,45
D627	M5 - M6 - M7 - M8 - M9 - M10 - M11 - M12	Nº 1 Nº 2	20 x 7 25 x 9 30 x 11 38 x 14	TC1	39	-	865,42
D625	M3 - M4 - M5 - M6 - M8 - M10 - M12 - M14 M16 - M18 - M20 - M22 - M24	Nº 1 Nº 4	20 x 5 20 x 7 25 x 9 30 x 11 38 x 14 45 x 18 55 x 22	-	61	2.044,04	1.508,17
D628	M5 - M6 - M8 - M10 - M12 - M14 - M16 M18 - M20 - M22 - M24 - M27 - M30	Nº 1 Nº 3 Nº 5	20 x 7 25 x 9 30 x 11 38 x 14 45 x 18 55 x 22 65 x 25	-	62	-	2.760,51

CONJUNTOS DE MACHOS E CAÇONETES HSS EM CAIXA METÁLICA

MF

HSS







Ref. D634

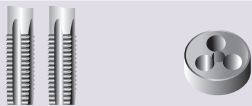

Ref. D636

CONTEÚDO

					Nº Peças	1ª Qualidade €	2ª Qualidade €
D634	MF 3 x 0.35 - 4 x 0.5 - 5 x 0.5 MF 6 x 0.75 - 8 x 0.75 - 8 x 1.0 MF 10 x 1.0 - 12 x 1.5	Nº 1 Nº 2	20 x 5 25 x 9 30 x 11 38 x 10	TC1	31	-	794,00
D635	MF 6 x 0.75 - 8 x 0.75 - 8 x 1.0 - 10 x 1.0 MF 12 x 1.0 - 12 x 1.5 - 14 x 1.25 - 14 x 1.5 MF 16 x 1.5 - 18 x 1.5 - 20 x 1.5	Nº 1 Nº 3	20 x 7 25 x 9 30 x 11 38 x 10 45 x 14	-	40	1.295,17	1.231,61
D636	MF 6 x 0.75 - 8 x 0.75 - 8 x 1.0 - 10 x 1.0 MF 12 x 1.0 - 12 x 1.5 - 14 x 1.25 - 14 x 1.5 MF 16 x 1.5 - 18 x 1.5 - 20 x 1.5 - 22 x 1.5 MF 24 x 1.5	Nº 1 Nº 4	20 x 7 25 x 9 30 x 11 38 x 10 45 x 14 55 x 16	-	47	1.776,74	1.642,72

CONJUNTOS DE MACHOS E CAÇONETES HSS EM CAIXA METÁLICA

**BSP
(GAS)**

HSS

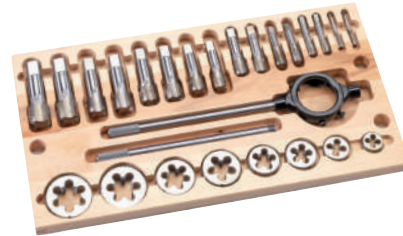

Ref. D638

CONTEÚDO

						Nº Peças	1ª Qualidade €	2ª Qualidade €
D637	G 1/8 - 1/4 - 3/8 - 1/2 - 3/4 - 1"	Nº 1 Nº 3 Nº 5	30 x 11 38 x 10 45 x 14 55 x 16 65 x 18	-	26	1.438,04	1.161,63	
D638	G 1/8 - 1/4 - 3/8 - 1/2 - 5/8 - 3/4 - 7/8 - 1"	Nº 1 Nº 3 Nº 5	30 x 11 38 x 10 45 x 14 55 x 16 65 x 18	-	32	1.951,57	1.703,58	
D639	G 1/4 - 3/8 - 1/2 - 3/4 - 1" - 1".1/4 - 1".1/2	Nº 2 Nº 4 Nº 7	38 x 10 45 x 14 55 x 16 65 x 18 75 x 20 90 x 22	-	30	3.600,32	3.037,02	

BSW

HSS

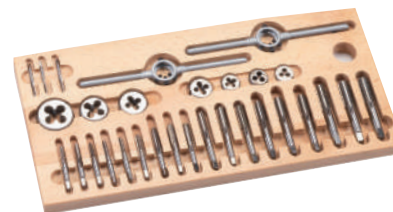

Ref. D640

CONTEÚDO

						Nº Peças	1ª Qualidade €	2ª Qualidade €
D640	BSW 1/8 - 3/16 - 1/4 - 5/16 - 3/8 - 7/16 - 1/2	Nº 1 Nº 2	20 x 5 20 x 7 25 x 9 30 x 11 38 x 14	TC1	36	802,23	685,78	
D641	BSW 1/4 - 5/16 - 3/8 - 7/16 - 1/2	Nº 1 Nº 2	20 x 7 25 x 9 30 x 11 38 x 14	TC1	27	661,33	557,02	
D642	BSW 1/4 - 5/16 - 3/8 - 7/16 - 1/2 - 5/8 - 3/4	Nº 1 Nº 3	20 x 7 25 x 9 30 x 11 38 x 14 45 x 18	-	35	1.183,54	1.079,93	
D643	BSW 1/4 - 5/16 - 3/8 - 7/16 1/2 - 5/8 - 3/4 - 7/8 - 1"	Nº 1 Nº 4	20 x 7 25 x 9 30 x 11 38 x 14 45 x 18 55 x 22	-	44	1.673,80	1.469,54	
D646	BSW 1/4 - 5/16 - 3/8 - 7/16 1/2 - 5/8 - 3/4 - 7/8 - 1" - 1".1/8 1".1/4 - 1".3/8 - 1".1/2	Nº 1 Nº 3 Nº 5	20 x 7 25 x 9 30 x 11 38 x 14 45 x 18 55 x 22 65 x 25	-	62	-	4.465,59	

CONJUNTOS DE MACHOS E CAÇONETES HSS EM CAIXA METÁLICA





BSF

HSS

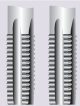

Ref. D648

CONTEÚDO

						Nº Peças	1ª Qualidade €	2ª Qualidade €
D664	BSF 1/4 - 5/16 - 3/8 - 7/16 - 1/2		Nº 1 Nº 2	20 x 7 25 x 9 30 x 11 38 x 10	TC1	22	739,56	650,51
D648	BSF 1/4 - 5/16 - 3/8 - 7/16 - 1/2 - 5/8 - 3/4		Nº 1 Nº 3	20 x 7 25 x 9 30 x 11 38 x 10 45 x 14	-	28	1.148,09	1.079,93
D665	BSF 1/4 - 5/16 - 3/8 - 7/16 1/2 - 5/8 - 3/4 - 7/8 - 1"		Nº 1 Nº 4	20 x 7 25 x 9 30 x 11 38 x 10 45 x 14 55 x 16	-	35	1.948,12	1.713,55



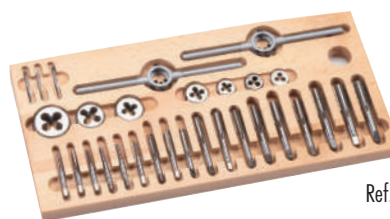

BSW
BSF

HSS

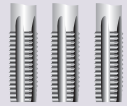

Ref. D666

CONTEÚDO

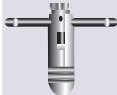
						Nº Peças	1ª Qualidade €	2ª Qualidade €
D666	BSW 1/4 - 5/16 - 3/8 - 7/16 - 1/2 - 5/8 - 3/4 BSF 1/4 - 5/16 - 3/8 - 7/16 - 1/2 - 5/8 - 3/4		Nº 1 Nº 3	20 x 7 25 x 9 30 x 11 38 x 14 45 x 18	-	63	2.200,66	1.935,68

CONJUNTOS DE MACHOS E CAÇONETES HSS EM CAIXA METÁLICA





NPT

HSS



Ref. D660

CONTEÚDO

						Nº Peças	1ª Qualidade €	2ª Qualidade €
D660	NPT 1/8 - 1/4 - 3/8 - 1/2 - 3/4 - 1"		Nº 1 Nº 3 Nº 5	30 x 11 38 x 14 45 x 18 55 x 22 65 x 25	-	20	2.080,19	1.973,16
D661	NPT 1/8 - 1/4 - 3/8 - 1/2 - 3/4 1" - 1".1/4 - 1".1/2 - 2"		Nº 2 Nº 4 Nº 7	30 x 11 38 x 14 45 x 18 55 x 22 65 x 25 75 x 30 90 x 36 105 x 36	-	29	6.227,02	5.850,26





UNC

HSS

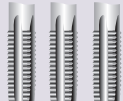

Ref. D650

CONTEÚDO

						Nº Peças	1ª Qualidade €	2ª Qualidade €
D650	UNC 1/4 - 5/16 - 3/8 - 7/16 - 1/2		Nº 1 Nº 2	20 x 7 25 x 9 30 x 11 38 x 14	TC1	27	806,09	723,50
D667	UNC 1/4 - 5/16 - 3/8 - 7/16 - 1/2 - 5/8 - 3/4		Nº 1 Nº 2	20 x 7 25 x 9 30 x 11 38 x 14 45 x 18	-	35	1.298,75	1.142,36
D654	UNC 1/4 - 5/16 - 3/8 - 7/16 1/2 - 5/8 - 3/4 - 7/8 - 1"		Nº 1 Nº 4	20 x 7 25 x 9 30 x 11 38 x 14 45 x 18 55 x 22	-	44	2.095,65	1.961,26
D668	UNC 1/4 - 5/16 - 3/8 - 7/16 - 1/2 - 5/8 - 3/4 7/8 - 1" - 1.1/8 - 1.1/4 - 1".3/8 - 1".1/2"		Nº 1 Nº 3 Nº 6	20 x 7 25 x 9 30 x 11 38 x 14 45 x 18 55 x 22 65 x 25	-	62	4.906,35	4.315,59

CONJUNTOS DE MACHOS E CAÇONETES HSS EM CAIXA METÁLICA





UNF

HSS



Ref. D644

CONTEÚDO

					Nº Peças	1ª Qualidade €	2ª Qualidade €
D644	UNF 1/4 - 5/16 - 3/8 - 7/16 - 1/2	Nº 1 Nº 2	20 x 7 25 x 9 30 x 11 38 x 10	TC1	22	631,65	547,58
D669	UNF 1/4-5/16 -3/8 -7/16 -1/2 -5/8 -3/4	Nº 1 Nº 3	20 x 7 25 x 9 30 x 11 38 x 10 45 x 14	-	28	1.190,50	1.047,16
D645	UNF 1/4 - 5/16 - 3/8 - 7/16 - 1/2 - 5/8 3/4 - 7/8 - 1"	Nº 1 Nº 4	20 x 7 25 x 9 30 x 11 38 x 10 45 x 14 55 x 16	-	34	1.459,80	1.323,60



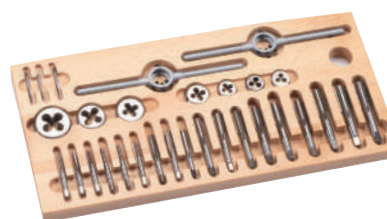

UNC
UNF

HSS

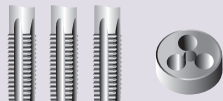

Ref. D670

CONTEÚDO

					Nº Peças	1ª Qualidade €	2ª Qualidade €
D670	UNC 1/4 - 5/16 - 3/8 - 7/16 - 1/2 - 5/8 - 3/4 UNF 1/4 - 5/16 - 3/8 - 7/16 - 1/2 - 5/8 - 3/4	Nº 1 Nº 3	20 x 7 25 x 9 30 x 11 38 x 14 45 x 18	-	35	2.200,66	1.935,68

JOGOS DE MACHOS MANUAIS HSS E TiN EM ESTOJOS METÁLICOS



Ref. JMB0



Ref. JMB2



Ref. JMBT2

CONTEÚDO

					HSS		TiN*
					€		€
JMB2	M3 - M4 - M5 - M6 M8 - M10 - M12	-	-	-	204,49	JMBT2	406,02
JMB0	M3 - M4 - M5 - M6 M8 - M10 - M12	2.5 / 3.3 / 4.2 / 5.0 6.8 / 8.5 / 10.2 mm	-	-	233,25	JMBT0	455,63
JMB1	M3 - M4 - M5 - M6 M8 - M10 - M12	2.5 / 3.3 / 4.2 / 5.0 6.8 / 8.5 / 10.2 mm	Nº 1.1/2	-	251,04	JMBT1	390,43
JMB5	M3 - M4 - M5 - M6 M8 - M10 - M12	2.5 / 3.3 / 4.2 / 5.0 6.8 / 8.5 / 10.2 mm	Nº 1.1/2	TC1	266,64	JMBT5	409,11
JMBI2 (esq.)	M3 - M4 - M5 - M6 M8 - M10 - M12	-	-	-	368,07	JMBIT2	730,83
JMBI0 (esq.)	M3 - M4 - M5 - M6 M8 - M10 - M12	2.5 / 3.3 / 4.2 / 5.0 6.8 / 8.5 / 10.2 mm	-	-	419,86	JMBIT0	820,14
JMBI1 (esq.)	M3 - M4 - M5 - M6 M8 - M10 - M12	2.5 / 3.3 / 4.2 / 5.0 6.8 / 8.5 / 10.2 mm	Nº 1.1/2	-	451,88	JMBIT1	702,78

MACHOS MANUAIS TERCEIROS HSS E TiN EM ESTOJOS METÁLICOS



Ref. JMB3



Ref. JMB4

CONTEÚDO

3°					HSS		TiN*
					€		€
JMB3	M3 - M4 - M5 - M6 M8 - M10 - M12	-	-	-	93,87	JMBT3	117,55
JMB4	M3 - M4 - M5 - M6 M8 - M10 - M12	2.5 / 3.3 / 4.2 / 5.0 6.8 / 8.5 / 10.2 mm	-	-	116,83	JMBT4	155,29
JMB7	M3 - M4 - M5 - M6 M8 - M10 - M12	2.5 / 3.3 / 4.2 / 5.0 6.8 / 8.5 / 10.2 mm	Nº 1.1/2	-	133,69	JMBT7	215,41
JMB6	M3 - M4 - M5 - M6 M8 - M10 - M12	2.5 / 3.3 / 4.2 / 5.0 6.8 / 8.5 / 10.2 mm	Nº 1.1/2	TC1	144,77	JMBT6	229,60
JMBI3 (esq.)	M3 - M4 - M5 - M6 M8 - M10 - M12	-	-	-	168,97	JMBIT3	211,60
JMBI4 (esq.)	M3 - M4 - M5 - M6 M8 - M10 - M12	2.5 / 3.3 / 4.2 / 5.0 6.8 / 8.5 / 10.2 mm	-	-	210,30	JMBIT4	279,53



MACHOS MANUAIS HSSCo EM ESTOJOS METÁLICOS

HSSCo
5%

Ref. JMBX0

CONTEÚDO

INOX	 MOX	 HSSCo			€
JMBX0	M3 - M4 - M5 - M6 M8 - M10 - M12	2.5 / 3.3 / 4.2 / 5.0 6.8 / 8.5 / 10.2 mm	-	-	322,33
JMBX1	M3 - M4 - M5 - M6 M8 - M10 - M12	2.5 / 3.3 / 4.2 / 5.0 6.8 / 8.5 / 10.2 mm	Nº 1.1/2	-	339,23
JMBX2	M3 - M4 - M5 - M6 M8 - M10 - M12	-	-	-	304,80

CONTEÚDO

 1100 N/mm ²	 MOMD	 HSSCo			€
JMBMD0	M3 - M4 - M5 - M6 M8 - M10 - M12	2.5 / 3.3 / 4.2 / 5.0 6.8 / 8.5 / 10.2 mm	-	-	336,62
JMBMD1	M3 - M4 - M5 - M6 M8 - M10 - M12	2.5 / 3.3 / 4.2 / 5.0 6.8 / 8.5 / 10.2 mm	Nº 1.1/2	-	354,13
JMBMD2	M3 - M4 - M5 - M6 M8 - M10 - M12	-	-	-	320,88

ESTOJOS DE CAÇONETES HSS EM CAIXAS METÁLICAS



Ref. C5B3



CONTEÚDO

		HSS €
C5B3	M3 - M4 - M5 - M6 - M8 - M10 - M12	244,31
C5B3I (esq.)	M3 - M4 - M5 - M6 - M8 - M10 - M12	439,75

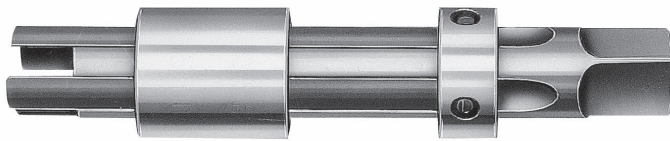

EXTRATOR DE MACHOS QUEBRADOS PARA MACHOS DE CANAIS RETOS, NÃO HELICOIDAIS



EXTRATORES SOLTOS

Ø MACHO A EXTRAIR		MACHOS MANUAIS	MACHOS DE MÁQUINA	€/ Ud.
BSW UNC	M			EXTRATOR INTEIRO
--	M3		W10043	46,59
1/8	M3,2		W10053	46,59
--	M3,5		W10063	46,59
5/32	M4		W10083	46,59
3/16	M5		W10103	46,59
--	M5,5	W10124	W10123	46,59
1/4	M6		W10253	47,96
5/16	M8	W10314	W10313	50,25
--	M9	W10374	W10373	49,78
3/8	M10	W10404	W10373	49,78
7/16	M11	W10434	W10433	52,55
1/2	M12	W10504	W10503	56,19
9/16	M14	W10564	W10563	77,65
5/8	M16	W10624	W10623	84,51
--	M18	W10684	W10753	104,71
3/4	M20	W10754	W10753	104,71
7/8	M22	W10874	W10873	114,58
1"	M25	W11004	W11003	127,77

VARETA DE REPOR

MACHOS MANUAIS	MACHOS DE MÁQUINA	€/ Ud.
		VARETA EXTRA
	W12043	2,48
	W12053	2,48
	W12063	2,48
	W12083	2,48
	W12103	3,70
	W12123	3,70
	W12253	4,51
W12314	W12313	5,09
W12374		5,09
W12404	W12373	5,25
W12434	W12433	5,34
W12504	W12503	6,72
W12564	W12563	7,49
W12624	W12623	9,58
W12684		9,58
W12754	W12753	10,14
W12874	W12873	13,13
W13004	W13003	21,86

3 SIMPLES PASSOS PARA EXTRAIR MACHOS QUEBRADOS DE CANAIS RETOS

Tirar toda a limança do macho quebrado. Introduzir as varetas do extrator nos canais do macho quebrado com firmeza até o fundo.

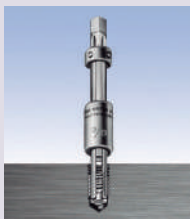

Empurre o suporte para baixo, até tocar o macho quebrado. Deslize o casquilho para baixo, até tocar a zona de trabalho.

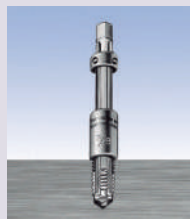

Aplicar ao quadrado do extrator um desandador. Gire a esquerdas umas quantas vezes até soltá-lo e então tire o macho quebrado.



JOGOS DE EXTRATORES PARA MACHOS QUEBRADOS (CANAIS RETOS)



Nº CANAIS	MEDIDAS INCLuíDAS PARA MACHOS DE MÁQUINA E MACHOS MANUAIS: 3 e 4 CANAIS	
W180013	3	M5- M6- M8- M10- M11- M12
W180014	4	3/16 - 1/4 - 5/16 - 3/8 - 7/16 - 1/2
W180023	3	M6- M8 -M10- M11- M12- M16
W180024	4	1/4 - 5/16 - 3/8 - 7/16 - 1/2 - 5/8
W180153	3	M3- M3,2- M3,5- M4-M5- M5,50- M6- M8
W180154	4	M9- M10- M12- M16- M18- M22- M25
		322,98
		363,37
		1.016,43

MACHOS PARA ROSCAGEM A MÁQUINA HSSCo

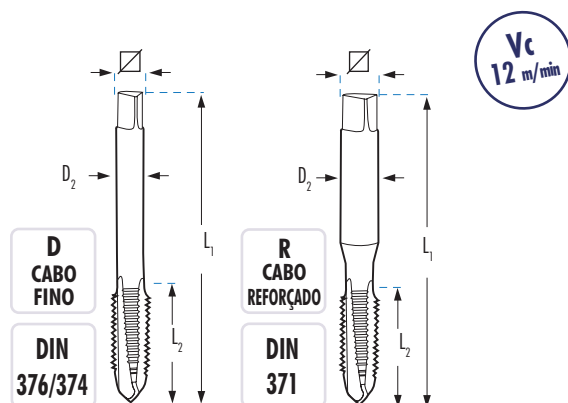
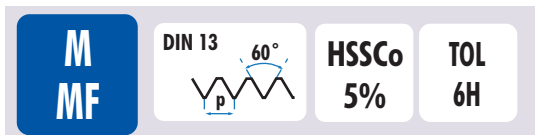





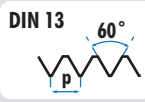

Machos	Ø	L1 x L2 x D2 x ∇ mm	M1D		M2D		M3D		M4D		M1R		M2R		M3R		M4R	
			FORMA C	FORMA B	FORMA C	FORMA B	FORMA C	FORMA B	FORMA C	FORMA B	FORMA C	FORMA B	FORMA C	FORMA B	FORMA C	FORMA B	FORMA C	FORMA B
			€	€	€	€	€	€	€	€	€	€	€	€	€	€	€	€
M 1x0,25	0,75	R 40 x 5,5 x 2,5 x 2,1										45,51						
M 1,1x0,25	0,85	R 40 x 6 x 2,5 x 2,1										44,27						
M 1,2x0,25	0,95	R 40 x 6 x 2,5 x 2,1										40,44						
M 1,4x0,30	1,10	R 40 x 7 x 2,5 x 2,1										40,44						
M 1,6x0,35	1,25	R 40 x 8 x 2,5 x 2,1										39,71						
M 1,7x0,35	1,35	R 40 x 8 x 2,5 x 2,1										38,24						
M 1,8x0,35	1,45	R 40 x 8 x 2,5 x 2,1										37,30						
M 2x0,40	1,60	R 40 x 8 x 2,8 x 2,1										17,96	19,90	22,25	22,67			
M 2,2x0,45	1,75	R 40 x 9 x 2,8 x 2,1										19,41						
M 2,3x0,40	1,90	R 40 x 9 x 2,8 x 2,1										17,88						
M 2,5x0,45	2,05	R 50 x 9 x 2,8 x 2,1										17,96	19,90	31,28	22,67			
M 2,6x0,45	2,10	R 50 x 9 x 2,8 x 2,1										17,99	20,25					37,68
M 3x0,50	2,50	R 56 x 11 x 3,5 x 2,7 D 56 x 11 x 2,2 x 1,8	11,90	12,88	17,93	15,46					11,90*	12,09	17,58	15,84				
M 3x0,60	2,40	R 56 x 11 x 3,5 x 2,7										21,15	23,08					30,48
M 3,5x0,60	2,90	R 56 x 12 x 4,0 x 3,0 D 56 x 12 x 2,5 x 2,1										17,29	18,00	23,25	21,82			
M 3,5x0,75	2,75	R 56 x 12 x 4,0 x 3,0										22,86						
M 4x0,50	3,50	R 63 x 13 x 4,5 x 3,4 D 63 x 13 x 2,8 x 2,1	26,05	28,69		30,33						24,90	27,70					32,07
M 4x0,70	3,30	R 63 x 13 x 4,5 x 3,4 D 63 x 13 x 2,8 x 2,1	12,11	13,02	19,23	15,31						13,53*	12,77	17,35	15,86			
M 4x0,75	3,25	R 63 x 13 x 4,5 x 3,4										18,93	20,21					
M 4x0,80	3,20	R 63 x 13 x 4,5 x 3,4										100,49						
M 4,5x0,50	4,00	R 70 x 14 x 6,0 x 4,9											32,22					
M 4,5x0,75	3,75	R 70 x 14 x 6,0 x 4,9										23,36	25,73					
M 5x0,50	4,50	R 70 x 14 x 6,0 x 4,9 D 70 x 11 x 3,5 x 2,7	26,83	29,47		30,67						25,64	28,46					34,21
M 5x0,75	4,50	R 74 x 14 x 6,0 x 4,9 D 70 x 16 x 3,5 x 2,7										23,00	26,97					33,99
M 5x0,80	4,20	R 70 x 16 x 6,0 x 4,9 D 70 x 16 x 3,5 x 2,7	12,11	13,09	18,43	14,70						12,12*	12,79	16,64	15,20			
M 5x0,90	4,10	R 70 x 15 x 6,0 x 4,9 D 70 x 16 x 3,5 x 2,7										20,00	25,77					
M 5x1,00	4,00	R 72 x 17 x 6,0 x 4,9										53,57						
M 5,5x0,90	4,60	R 80 x 17 x 6,0 x 4,9										53,57						
M 6x0,50	5,50	R 80 x 17 x 6,0 x 4,9 D 80 x 13 x 4,5 x 3,4	31,76	38,94		49,14						33,57						
M 6x0,75	5,25	R 80 x 13 x 6,0 x 4,9 D 80 x 13 x 4,5 x 3,4	20,93	24,23		28,30						21,75	25,34					30,43
M 6x1,00	5,00	R 80 x 19 x 6,0 x 4,9 D 80 x 19 x 4,5 x 3,4	13,81	14,34	19,28	16,12						13,79*	14,03	18,26	16,67			

* Consulte o preço dos jogos de machos e caçonetes à esquerda disponíveis na Pag.215

MACHOS PARA ROSCAGEM A MÁQUINA HSSCo

M MF  **HSSCo 5%** **TOL 6H** **D CABO FINO** **DIN 376/374**  **R CABO REFORÇADO** **DIN 371**

			L1 x L2 x D2 x  mm	M1D	M2D	M3D	M4D	M1R	M2R	M3R	M4R
				FORMA C €	FORMA B €	 15° €	 35° €	FORMA C €	FORMA B €	 15° €	 35° €
M 6x1,25		4,75	R 80 x 17 x 6,0 x 4,9					52,66			
M 7x0,75		6,25	D 80 x 13 x 5,5 x 4,3	26,94	29,88		36,91				
M 7x1,00		6,00	R 80 x 19 x 7,0 x 5,5 D 80 x 19 x 5,5 x 4,3	18,57	21,47	23,19	22,32	17,88 *	20,87	23,60	23,36
M 8x0,50		7,50	D 80 x 13 x 6 x 4,9	36,24							
M 8x0,75		7,25	D 80 x 13 x 6 x 4,9	26,25	32,19		39,92				
M 8x1,00		7,00	D 90 x 20 x 6 x 4,9	21,47	24,64	29,53	27,30				
M 8x1,25		6,80	R 90 x 22 x 8 x 6,2 D 90 x 22 x 6 x 4,9	15,49	16,18	21,95	18,82	15,58 *	15,59	21,02	19,05
M 8x1,50		6,50	D 90 x 20 x 6 x 4,9	106,20							
M 9x1,00		8,00	D 90 x 20 x 7 x 5,5	32,47	34,71		36,89				
M 9x1,25		7,80	R 90 x 22 x 9 x 7,0 D 90 x 22 x 7 x 5,5	26,09	27,42	33,20	32,46	25,84	26,18	33,47	33,39
M 10x0,50		9,50	D 90 x 20 x 7 x 5,5	105,22							
M 10x0,75		9,25	D 90 x 16 x 7 x 5,5	41,62	41,71		50,79				
M 10x1,00		9,00	D 90 x 16 x 7 x 5,5	23,77	27,38	34,86	33,21				
M 10x1,25		8,80	D 100 x 22 x 7 x 5,5	27,22	32,74	38,00	36,19				
M 10x1,50		8,50	R 100 x 24 x 10 x 8,0 D 100 x 24 x 7 x 5,5	17,50	19,57	26,09	22,55	17,66 *	19,20	24,14	22,55
M 11x1,00		10,00	D 90 x 20 x 8 x 6,2	42,61	44,01	111,26	101,24				
M 11x1,25		9,75	D 100 x 22 x 8 x 6,2	40,77	45,30	111,26	90,37				
M 11x1,50		9,50	D 100 x 24 x 8 x 6,2	33,05	38,00	81,12	73,78				
M 12x0,75		11,25	D 100 x 22 x 9 x 7,0	62,43							
M 12x1,00		11,00	D 100 x 22 x 9 x 7,0	32,33	37,00	43,01	42,55				
M 12x1,25		10,75	D 100 x 22 x 9 x 7,0	32,73	36,35	41,18	40,73				
M 12x1,50		10,50	D 100 x 22 x 9 x 7,0	29,25*	32,42	39,60	39,18				
M 12x1,75		10,20	D 110 x 28 x 9 x 7,0	21,08*	24,44	33,37	28,76				
M 13x0,75		12,25	D 100 x 22 x 11 x 9,0	108,97							
M 13x1,00		12,00	D 100 x 22 x 11 x 9,0	57,71	65,34						
M 13x1,25		11,75	D 100 x 22 x 11 x 9,0	57,71	65,34						
M 13x1,50		11,50	D 100 x 22 x 11 x 9,0	57,71	65,34						
M 13x1,75		11,25	D 100 x 28 x 11 x 9,0	57,30	65,34						
M 14x0,75		13,25	D 100 x 22 x 11 x 9,0	108,97							
M 14x1,00		13,00	D 100 x 22 x 11 x 9,0	52,04	57,25	66,31	65,75				
M 14x1,25		12,80	D 100 x 22 x 11 x 9,0	44,29	48,34	60,82	57,94				
M 14x1,50		12,50	D 100 x 22 x 11 x 9,0	34,84*	38,39	47,96	45,69				
M 14x2,00		12,00	D 110 x 30 x 11 x 9,0	34,61*	38,45	44,56	44,56				
M 15x1,00		14,00	D 100 x 22 x 12 x 9,0	66,18	70,07		89,22				
M 15x1,25		13,75	D 100 x 22 x 12 x 9,0	70,89	76,77						
M 15x1,50		13,50	D 100 x 22 x 12 x 9,0	56,66	64,62	165,08	133,91				
M 15x2,00		13,00	D 110 x 30 x 12 x 9,0	69,35	76,32						
M 16x1,00		15,00	D 100 x 22 x 12 x 9,0	62,38	66,18	92,84	90,14				
M 16x1,25		14,75	D 100 x 22 x 12 x 9,0	66,75	73,37	103,25	99,98				
M 16x1,50		14,50	D 100 x 22 x 12 x 9,0	41,19*	48,00	59,77	56,94				
M 16x2,00		14,00	D 110 x 32 x 12 x 9,0	40,73*	44,98	53,83	53,83				
M 17x1,00		16,00	D 100 x 22 x 12 x 9,0	124,11							
M 17x1,25		15,75	D 100 x 22 x 12 x 9,0	124,11							
M 17x1,50		15,50	D 100 x 22 x 12 x 9,0	124,11							
M 18x1,00		17,00	D 110 x 25 x 14 x 11,0	69,86	76,78		110,30				
M 18x1,25		16,75	D 110 x 25 x 14 x 11,0	86,58							
M 18x1,50		16,50	D 110 x 25 x 14 x 11,0	54,54*	60,02	73,45	71,46				
M 18x2,00		16,00	D 125 x 30 x 14 x 11,0	76,97	85,29	145,34	129,72				

* Consulte o preço dos jogos de machos e caçonetes à esquerda disponíveis na Pag.215

Machos e Caçonetes
Rosa

MACHOS PARA ROSCAGEM A MÁQUINA HSSCo

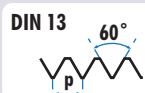
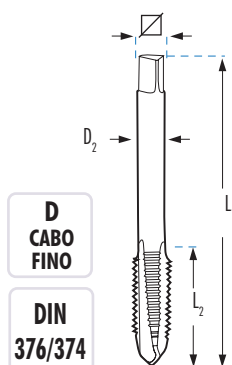
M
MFHSSCo
5%TOL
6HD
CABO
FINODIN
376/374Vc
12 m/min

M	Ø	L1 x L2 x D2 x Ø mm	FORMA			
			C	B	15°	35°
			€	€	€	€
M 18x2,50	15,50	D 125 x 34 x 14 x 11,0	58,60*	64,07	72,48	69,80
M 19x1,00	18,00	D 110 x 22 x 14 x 11,0	163,07			
M 19x1,25	17,75	D 110 x 25 x 14 x 11,0	167,70			
M 19x1,50	17,50	D 110 x 25 x 14 x 11,0	160,06			
M 20x1,00	19,00	D 125 x 25 x 16 x 12,0	92,22	102,41		117,81
M 20x1,25	18,75	D 125 x 25 x 16 x 12,0	163,07			
M 20x1,50	18,50	D 125 x 25 x 16 x 12,0	61,77*	67,88	82,55	81,64
M 20x2,00	18,00	D 140 x 32 x 16 x 12,0	80,96	89,01		105,09
M 20x2,50	17,50	D 140 x 34 x 16 x 12,0	62,38*	69,17	77,35	77,36
M 21x1,00	20,00	D 125 x 25 x 16 x 12,0	236,76			
M 21x1,25	19,75	D 125 x 25 x 16 x 12,0	236,76			
M 21x1,50	19,50	D 125 x 25 x 16 x 12,0	226,11			
M 22x1,00	21,00	D 125 x 25 x 18 x 14,5	103,38	109,73		151,82
M 22x1,25	20,75	D 125 x 25 x 18 x 14,5	163,07			
M 22x1,50	20,50	D 125 x 25 x 18 x 14,5	74,35	81,78	90,55	85,20
M 22x2,00	20,00	D 140 x 32 x 18 x 14,5	103,38	113,70		151,82
M 22x2,50	19,50	D 140 x 34 x 18 x 14,5	75,48*	83,02	91,76	90,80
M 23x1,00	22,00	D 125 x 25 x 18 x 14,5	230,18			
M 23x1,50	21,50	D 125 x 25 x 18 x 14,5	230,18			
M 24x1,00	23,00	D 140 x 25 x 18 x 14,5	112,65	136,66		160,41
M 24x1,25	22,75	D 140 x 25 x 18 x 14,5	236,76			
M 24x1,50	22,50	D 140 x 28 x 18 x 14,5	91,44	100,54	121,03	115,29
M 24x2,00	22,00	D 140 x 28 x 18 x 14,5	116,67*	127,11		137,16
M 24x3,00	21,00	D 160 x 38 x 18 x 14,5	90,36*	98,90	110,59	110,37
M 25x1,00	24,00	D 140 x 28 x 18 x 14,5	218,39			
M 25x1,25	23,75	D 140 x 28 x 18 x 14,5	345,09			
M 25x1,50	23,50	D 140 x 28 x 18 x 14,5	142,28	150,58		
M 25x2,00	23,00	D 140 x 28 x 18 x 14,5	306,26	336,90		
M 26x1,00	25,00	D 140 x 28 x 18 x 14,5	169,55			
M 26x1,50	24,50	D 140 x 28 x 18 x 14,5	123,31	129,26	226,74	199,38
M 26x2,00	24,00	D 140 x 28 x 18 x 14,5	238,83	262,72		288,56
M 27x1,00	26,00	D 140 x 28 x 20 x 16,0	151,86	196,08		
M 27x1,50	25,50	D 140 x 28 x 20 x 16,0	134,64	142,63	329,52	297,12
M 27x2,00	25,00	D 140 x 28 x 20 x 16,0	166,54*	176,22		

* Consulte o preço dos jogos de machos e caçonetes à esquerda disponíveis na Pag.215

MACHOS PARA ROSCAGEM A MÁQUINA HSSCo

M
MF

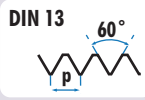







HSSCo
5%

TOL
6H

D
CABO
FINO

DIN
376/374



			L1 x L2 x D2 x  mm	M1D	M2D	M3D	M4D
				FORMA C	FORMA B	 15°	 35°
				€	€	€	€
M 27x3,00	24,00	D	160 x 36 x 20 x 16	112,80*	123,70	136,06	135,80
M 28x1,00	27,00	D	140 x 28 x 20 x 16	306,26			
M 28x1,50	26,50	D	140 x 28 x 20 x 16	134,64	147,82	171,60	154,93
M 28x2,00	26,00	D	140 x 28 x 20 x 16	164,26	185,51	202,23	198,87
M 30x1,00	29,00	D	150 x 28 x 22 x 18	172,21	199,13		232,17
M 30x1,50	28,50	D	150 x 28 x 22 x 18	140,34	154,42	186,09	177,24
M 30x2,00	28,00	D	150 x 28 x 22 x 18	173,71*	184,37		255,11
M 30x3,50	26,50	D	180 x 40 x 22 x 18	144,55*	158,93	174,38	174,02
M 32x1,00	31,00	D	150 x 28 x 22 x 18	408,38	433,63		
M 32x1,50	30,50	D	150 x 28 x 22 x 18	177,58	194,96	229,28	
M 32x2,00	30,00	D	150 x 28 x 22 x 18	218,20	334,11		
M 33x1,00	32,00	D	160 x 30 x 25 x 20	376,11			
M 33x1,50	31,50	D	160 x 30 x 25 x 20	200,07	212,19		246,97
M 33x2,00	31,00	D	160 x 30 x 25 x 20	327,90	335,17		409,00
M 33x3,50	29,50	D	180 x 40 x 25 x 20	173,71*	199,88		221,70
M 34x1,50	32,50	D	170 x 30 x 28 x 22	222,82	236,04		
M 34x2,00	32,00	D	160 x 30 x 28 x 22	468,60			
M 35x1,50	33,50	D	170 x 30 x 28 x 22	234,99	258,48		282,66
M 35x2,00	33,00	D	170 x 30 x 28 x 22	432,41	476,03		
M 36x1,50	34,50	D	170 x 30 x 28 x 22	214,57	253,67		307,06
M 36x2,00	34,00	D	170 x 30 x 28 x 22	289,81	301,25		
M 36x3,00	33,00	D	200 x 50 x 28 x 22	332,50	345,58		444,41
M 36x4,00	32,00	D	200 x 50 x 28 x 22	227,99*	244,25	283,71	271,46
M 38x1,50	36,50	D	170 x 30 x 28 x 22	228,74	257,73		
M 38x2,00	36,00	D	170 x 32 x 28 x 22	486,19	534,84		
M 39x1,50	37,50	D	170 x 32 x 32 x 24	359,45			
M 39x2,00	37,00	D	170 x 32 x 32 x 24	359,45			
M 39x3,00	36,00	D	200 x 47 x 32 x 24	469,40			
M 39x4,00	35,00	D	200 x 50 x 32 x 24	273,53	284,33		350,60
M 40x1,50	38,50	D	170 x 30 x 32 x 24	299,09	329,21		
M 40x2,00	38,00	D	170 x 30 x 32 x 24	360,39			
M 40x3,00	37,00	D	200 x 47 x 32 x 24	353,35	421,56		
M 42x1,50	40,50	D	170 x 30 x 32 x 24	326,35	318,95		
M 42x2,00	40,00	D	170 x 30 x 32 x 24	412,28			
M 42x3,00	39,00	D	200 x 45 x 32 x 24	412,28	493,71		
M 42x4,50	37,50	D	200 x 56 x 32 x 24	351,73	365,51		390,84
M 45x1,50	43,50	D	180 x 32 x 36 x 29	389,78	428,72		
M 45x2,00	43,00	D	180 x 32 x 36 x 29	477,38			
M 45x3,00	42,00	D	200 x 47 x 36 x 29	477,38			
M 45x4,50	40,50	D	220 x 58 x 36 x 29	384,21	422,60		
M 48x1,50	46,50	D	190 x 32 x 36 x 29	384,21			
M 48x2,00	46,00	D	190 x 32 x 36 x 29	620,81			
M 48x3,00	45,00	D	220 x 52 x 36 x 29	578,50			
M 48x5,00	43,00	D	250 x 65 x 36 x 29	472,47	519,69		
M 50x1,50	48,50	D	190 x 32 x 36 x 29	465,66			
M 52x1,50	50,50	D	190 x 32 x 40 x 32	454,90			
M 52x2,00	50,00	D	190 x 32 x 40 x 32	719,89			
M 52x3,00	49,00	D	225 x 50 x 40 x 32	739,85			
M 52x5,00	47,00	D	250 x 65 x 40 x 32	483,87	598,70		

* Consulte o preço dos jogos de machos e caçonetes à esquerda disponíveis na Pag.215

MACHOS PARA ROSCAGEM A MÁQUINA HSSCo

UNC

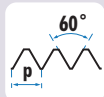
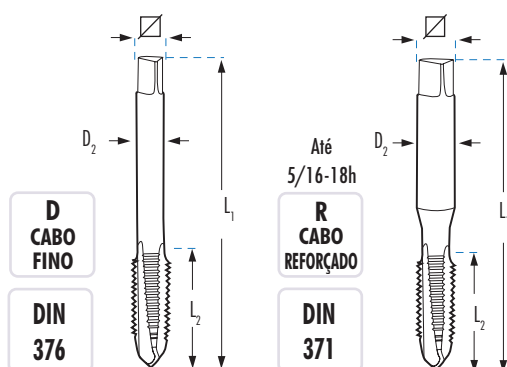
HSSCo
5%TOL
2BVc
12 m/min

	D1 mm	Ø	L1 x L2 x D2 x ∇ mm	M1R	M2R	M4R
				FORMA C	FORMA B	35°
				€	€	€
UNC nº 4-40h	2,84	2,25	R 56 x 11 x 3,5 x 2,7	26,92	32,01	36,53
UNC nº 5-40h	3,17	2,60	R 56 x 11 x 3,5 x 2,7	27,90	33,47	36,53
UNC nº 6-32h	3,50	2,75	R 56 x 12 x 4,0 x 3,0	26,55	31,91	36,37
UNC nº 8-32h	4,17	3,50	R 63 x 13 x 4,5 x 3,4	26,55	31,91	34,79
UNC nº 10-24h	4,83	3,90	R 70 x 15 x 6,0 x 4,9	27,90	33,47	38,21
UNC nº 12-24h	5,49	4,50	R 80 x 16 x 6,0 x 4,9	29,27	33,47	35,07
UNC 1/4-20h	6,35	5,10	R 80 x 17 x 7,0 x 5,5	26,08	28,43	32,81
UNC 5/16-18h	7,94	6,60	R 90 x 20 x 8,0 x 6,2	29,52	32,54	37,05

	CABO FINO			M1D	M2D	M4D
			D			
UNC 3/8-16h	9,52	8,00	D 100 x 22 x 7,0 x 5,5	33,65	35,29	39,66
UNC 7/16-14h	11,11	9,40	D 100 x 22 x 8,0 x 6,2	46,32	46,47	58,12
UNC 1/2-13h	12,70	10,75	D 110 x 24 x 9,0 x 7,0	50,26	55,69	63,57
UNC 9/16-12h	14,28	12,20	D 110 x 26 x 11,0 x 9,0	69,09	75,86	86,30
UNC 5/8-11h	15,87	13,50	D 110 x 27 x 12,0 x 9,0	67,13	73,88	83,93
UNC 3/4-10h	19,05	16,50	D 125 x 30 x 14,0 x 11,0	88,87	97,70	111,16
UNC 7/8-9h	22,22	19,50	D 140 x 32 x 18,0 x 14,5	116,94	128,48	173,94
UNC 1"-8h	25,40	22,25	D 160 x 36 x 18,0 x 14,5	154,52	168,80	218,20
UNC 1.1/8-7h	28,57	25,00	D 180 x 40 x 22,0 x 18,0	201,83		243,80
UNC 1.1/4-7h	31,75	28,00	D 180 x 40 x 22,0 x 18,0	236,57		311,89
UNC 1.3/8-6h	34,92	30,75	D 200 x 50 x 28,0 x 22,0	352,86		
UNC 1.1/2-6h	38,10	34,00	D 200 x 50 x 32,0 x 24,0	400,72		

MACHOS PARA ROSCAGEM A MÁQUINA HSSCo

UNF



HSSCo
5%

TOL
2B

Vc
12 m/min

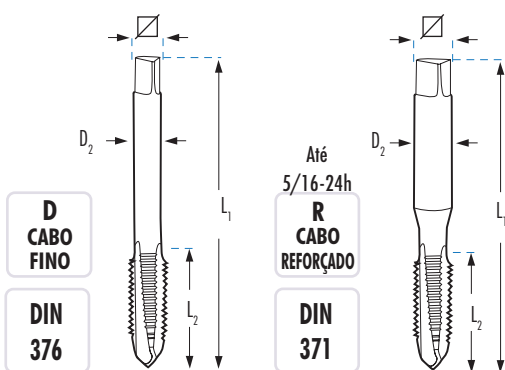

UNF nº	D1 mm	D2 mm	R	L1 x L2 x D2 x mm	M1R	M2R	M4R
					FORMA C	FORMA B	FORMA 35°
					€	€	€
UNF nº 4-48h	2,84	2,35	R	56 x 11 x 3,5 x 2,7	28,18	30,68	38,51
UNF nº 5-44h	3,17	2,70	R	56 x 11 x 3,5 x 2,7	28,18	30,68	38,51
UNF nº 6-40h	3,50	2,95	R	56 x 12 x 4,0 x 3,0	26,95	32,28	38,22
UNF nº 8-36h	4,17	3,50	R	63 x 13 x 4,5 x 3,4	26,95	32,28	38,22
UNF nº 10-32h	4,83	4,10	R	70 x 15 x 6,0 x 4,9	26,95	32,28	38,22
UNF nº 12-28h	5,49	4,60	R	80 x 16 x 6,0 x 4,9	28,18	33,77	38,51
UNF 1/4-28h	6,35	5,50	R	80 x 17 x 7,0 x 5,5	22,76	24,38	28,44
UNF 5/16-24h	7,94	6,90	R	90 x 20 x 8,0 x 6,2	25,45	28,06	32,80

CABO FINO				M1D	M2D	M4D	
UNF	D	D	D				
UNF 3/8-24h	9,52	8,50	D	90 x 16 x 7,0 x 5,5	27,87	32,24	41,03
UNF 7/16-20h	11,11	9,90	D	100 x 22 x 8,0 x 6,2	34,38	39,85	52,61
UNF 1/2-20h	12,70	11,50	D	100 x 22 x 9,0 x 7,0	36,60	42,37	55,97
UNF 9/16-18h	14,29	12,90	D	100 x 22 x 11,0 x 9,0	44,97	52,08	69,30
UNF 5/8-18h	15,87	14,50	D	100 x 22 x 12,0 x 9,0	50,63	58,58	77,43
UNF 3/4-16h	19,05	17,50	D	110 x 25 x 14,0 x 11,0	64,79	75,02	99,04
UNF 7/8-14h	22,22	20,40	D	125 x 25 x 18,0 x 14,5	81,47	101,91	151,49
UNF 1"-12h	25,40	23,25	D	140 x 28 x 18,0 x 14,5	122,63	133,53	178,30
UNS 1"-14h	25,40	23,60	D	140 x 28 x 18,0 x 14,5	123,18	137,36	178,31
UNF 1.1/8-12h	28,57	26,50	D	150 x 28 x 22,0 x 18,0	186,85		
UNF 1.1/4-12h	31,75	29,50	D	150 x 28 x 22,0 x 18,0	236,12		
UNF 1.1/2-12h	38,10	36,00	D	170 x 30 x 32,0 x 24,0	396,29		

MACHOS PARA ROSCAGEM A MÁQUINA HSSCo

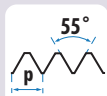
BSP
(GAS)HSSCo
5%TOL
ISO 228

INOX

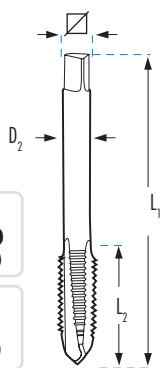
Vc
12 m/minVc
6 m/min

FORMA C	FORMA B	FORMA B	FORMA B	FORMA B	FORMA B	FORMA B	FORMA B	FORMA B	FORMA B
€	€	€	€	€	€	€	€	€	€
G 1/8-28h.	9,728	8,80	D 90 x 16 x 7 x 5,5	35,64 *	40,71	41,71	43,22	62,93	62,28
G 1/4-19h.	13,157	11,80	D 100 x 22 x 11 x 9,0	49,42 *	54,41	59,89	62,07	84,78	90,74
G 3/8-19h.	16,662	15,25	D 100 x 22 x 12 x 9,0	59,18 *	65,11	71,54	74,12	100,58	106,64
G 1/2-14h.	20,955	19,00	D 125 x 25 x 16 x 12,0	74,79 *	82,30	90,23	93,47	124,53	134,60
G 5/8-14h.	22,911	21,00	D 125 x 25 x 18 x 14,5	93,20 *	97,74	112,34	111,30		
G 3/4-14h.	26,441	24,50	D 140 x 28 x 20 x 16,0	117,06	128,85	141,23	146,33	188,16	207,59
G 7/8-14h.	30,201	28,25	D 150 x 28 x 22 x 18,0	157,36	165,54	189,95	188,17		
G 1"-11h.	33,249	30,75	D 160 x 30 x 25 x 20,0	181,71	199,84	216,86	224,70		
G 1.1/8-11h.	37,897	35,50	D 170 x 30 x 28 x 22,0	290,16	316,50		347,61		
G 1.1/4-11h.	41,910	39,50	D 170 x 30 x 32 x 24,0	340,46	358,22		396,56		
G 1.3/8-11h.	44,323	42,00	D 180 x 32 x 36 x 29,0	407,12			550,85		
G 1.1/2-11h.	47,803	45,25	D 190 x 32 x 36 x 29,0	542,89	756,81		716,95		
G 1.3/4-11h.	53,746	51,25	D 190 x 32 x 40 x 32,0	645,29	746,53				
G 2"-11h.	59,614	57,00	D 220 x 36 x 45 x 35,0	823,00	819,19				

* Disponíveis também com rosca esquerda com 100% de sobrecusto sobre os preços em rosca direita.

BSF

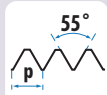
HSSCo
5%TOL
ISO 228Vc
12 m/minD
CABO
FINODIN
5156

FORMA C	FORMA C	FORMA C	FORMA C	FORMA C	FORMA C	FORMA C	FORMA C	FORMA C	FORMA C
€	€	€	€	€	€	€	€	€	€
BSF 3/16-32h.	4,762	4,00	D 70 x 16 x 3,5 x 2,7	81,54					
BSF 1/4-26h.	6,350	5,20	D 80 x 17 x 4,5 x 3,4	35,68					
BSF 5/16-22h.	7,938	6,60	D 90 x 20 x 6,0 x 4,9	42,37					
BSF 3/8-20h.	9,525	8,10	D 100 x 22 x 7,0 x 5,5	44,54					
BSF 7/16-18h.	11,113	9,50	D 100 x 22 x 8,0 x 6,2	60,03					
BSF 1/2-16h.	12,700	11,00	D 110 x 24 x 9,0 x 7,0	67,94					
BSF 9/16-16h.	14,287	12,50	D 110 x 25 x 11,0 x 9,0	71,90					
BSF 5/8-14h.	15,876	14,00	D 110 x 27 x 12,0 x 9,0	95,83					
BSF 3/4-12h.	19,051	16,50	D 125 x 30 x 14,0 x 11,0	113,44					
BSF 7/8-11h.	22,226	19,50	D 140 x 32 x 18,0 x 14,5	157,66					
BSF 1"-10h.	25,400	22,50	D 160 x 36 x 18,0 x 14,5	183,27					

MACHOS PARA ROSCAGEM A MÁQUINA HSSCo

BSW

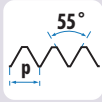

HSSCo
5%

TOL
Clase 2

Vc
12 m/min

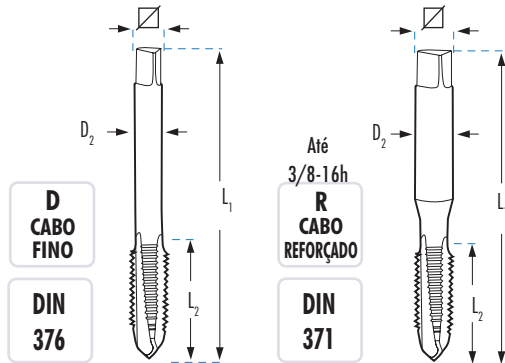

		 D1 mm	 Ø	L1 x L2 x D2 x mm	M1R	M2R	M3R	M4R
					FORMA C	FORMA B	15°	35°
W 3/32-48h.	2,38	1,80	R	50 x 9 x 2,8 x 2,1	24,77	26,44		
W 1/8-40h.	3,17	2,55	R	56 x 11 x 3,5 x 2,7	20,66 *	22,84	26,96	25,95
W 5/32-32h.	3,97	3,10	R	63 x 13 x 4,5 x 3,4	20,66	22,84	26,96	25,95
W 3/16-24h.	4,76	3,60	R	70 x 15 x 6,0 x 4,9	22,93	22,84	26,96	25,95
W 7/32-24h.	5,56	4,40	R	80 x 16 x 6,0 x 4,9	31,37	33,17		
W 1/4-20h.	6,35	5,10	R	80 x 17 x 7,0 x 5,5	22,07	25,95	30,61	31,71
W 5/16-18h.	7,94	6,50	R	90 x 20 x 8,0 x 6,2	24,75	32,72	35,72	35,66
W 3/8-16h.	9,52	7,90	R	100 x 22 x 10,0 x 8,0	27,70	36,16	39,70	39,64

CABO FINO				M1D	M2D	M3D	M4D	
W 7/16-14h.	11,11	9,25	D	100 x 22 x 8,0 x 6,2	38,52	39,83	50,04	50,40
W 1/2-12h.	12,70	10,50	D	110 x 24 x 9,0 x 7,0	36,94	41,53	47,94	48,29
W 9/16-12h.	14,29	12,00	D	110 x 26 x 11,0 x 9,0	52,95	54,99	68,76	69,25
W 5/8-11h.	15,87	13,40	D	110 x 27 x 12,0 x 9,0	50,14	51,95	65,03	65,48
W 3/4-10h.	19,05	16,50	D	125 x 30 x 14,0 x 11,0	70,17	72,84	87,12	87,74
W 7/8-9h.	22,22	19,25	D	140 x 32 x 18,0 x 14,5	90,89	94,25	117,93	113,56
W 1"-8h.	25,40	21,75	D	160 x 36 x 18,0 x 14,5	114,23	118,46	147,99	149,04
W 1.1/8-7h.	28,57	24,75	D	180 x 40 x 22,0 x 18,0	154,92	176,52	212,25	
W 1.1/4-7h.	31,75	27,75	D	180 x 40 x 22,0 x 18,0	225,05	256,48		
W 1.3/8-6h.	34,92	30,50	D	200 x 50 x 28,0 x 22,0	369,90	421,19		
W 1.1/2-6h.	38,10	33,50	D	200 x 50 x 32,0 x 24,0	401,50	457,58		
W 1.5/8-5h.	41,27	46,50	D	220 x 65 x 32,0 x 24,0	560,42	638,72		
W 1.3/4-5h.	44,45	39,00	D	220 x 58 x 36,0 x 29,0	600,27	689,06		
W 1.7/8-4,5h.	47,62	42,00	D	250 x 75 x 36,0 x 29,0	696,03	763,89		
W 2"-4,5h.	50,80	44,50	D	250 x 65 x 40,0 x 32,0	859,12			

* Disponíveis também com rosca esquerda com 100% de sobrecusto sobre os preços em rosca direita.

MACHOS PARA ROSCAGEM A MÁQUINA HSSCo

UNJC

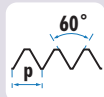
HSSCo
5%TOL
3B

UNJF

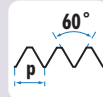
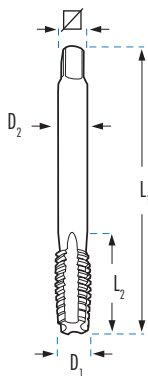
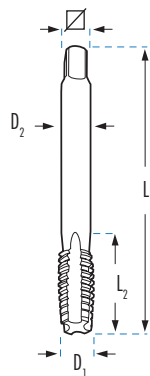
HSSCo
5%TOL
3BVc
12 m/minVc
12 m/min

FORMA C	D1 mm	Ø	L1 x L2 x D2 x Ø	MIR
				FORMA C
				€
	2,84	2,25	R 56 x 11 x 3,5 x 2,7	40,89
	3,17	2,60	R 56 x 11 x 3,5 x 2,7	40,89
	3,50	2,75	R 56 x 12 x 4,0 x 3,0	40,89
	4,17	3,50	R 63 x 13 x 4,5 x 3,4	40,89
	4,83	3,90	R 70 x 15 x 6,0 x 4,9	40,89
	5,49	4,50	R 80 x 16 x 6,0 x 4,9	42,89
	6,35	5,10	R 80 x 17 x 7,0 x 5,5	38,16
	7,94	6,60	R 90 x 20 x 8,0 x 6,2	43,18
	9,52	8,00	R 100 x 22 x 8,0 x 6,2	49,22

FORMA C	D1 mm	Ø	L1 x L2 x D2 x Ø	MIR
				FORMA C
				€
	2,84	2,35	R 56 x 11 x 3,5 x 2,7	44,86
	3,17	2,70	R 56 x 11 x 3,5 x 2,7	44,86
	3,50	2,95	R 56 x 12 x 4,0 x 3,0	44,86
	4,17	3,50	R 63 x 13 x 4,5 x 3,4	44,86
	4,83	4,10	R 70 x 15 x 6,0 x 4,9	44,86
	5,49	4,60	R 80 x 16 x 6,0 x 4,9	44,86
	6,35	5,50	R 80 x 17 x 7,0 x 5,5	34,83
	7,94	6,90	R 90 x 20 x 8,0 x 6,2	38,94
	9,52	8,50	R 90 x 16 x 7,0 x 6,2	42,64

CABO FINO PASSOS NORMAIS				M1D
UNJC 7/16-14h	11,11	9,40	D 110 x 24 x 9,0 x 7,0	67,88
UNJC 1/2-13h	12,70	10,75	D 110 x 26 x 11,0 x 9,0	73,68
UNJC 9/16-12h	14,28	12,20	D 110 x 27 x 12,0 x 9,0	101,27
UNJC 5/8-11h	15,87	13,50	D 110 x 27 x 12,0 x 9,0	103,81
UNJC 3/4-10h	19,05	16,50	D 125 x 30 x 14,0 x 11,0	130,25
UNJC 7/8-9h	22,22	19,50	D 140 x 32 x 18,0 x 14,5	171,39
UNJC 1"-8h	25,40	22,25	D 160 x 36 x 18,0 x 14,5	226,44

CABO FINO PASSOS NORMAIS				M1D
UNJF 7/16-20h	11,11	9,90	D 100 x 22 x 8,0 x 6,2	58,56
UNJF 1/2-20h	12,70	11,50	D 100 x 22 x 9,0 x 7,0	62,36
UNJF 9/16-18h	14,29	12,90	D 100 x 22 x 11,0 x 9,0	76,62
UNJF 5/8-18h	15,87	14,50	D 100 x 22 x 12,0 x 9,0	86,26
UNJF 3/4-16h	19,05	17,50	D 110 x 25 x 14,0 x 11,0	110,36
UNJF 7/8-14h	22,22	20,40	D 125 x 25 x 18,0 x 14,5	138,77
UNJF 1"-12h	25,40	23,25	D 140 x 28 x 18,0 x 14,5	154,72

MACHOS PARA ROSCAGEM A MÁQUINA HSSCo

Machos e Caçonetes

Rosa

BSP DIN 2999 55° HSSCo 5% DIN 374 FORMA C

BSPT BS21 ISO7/1 55° HSSCo 5% DIN 5156 FORMA C

ROSCA CILÍNDRICA INGLESA PARA TUBO

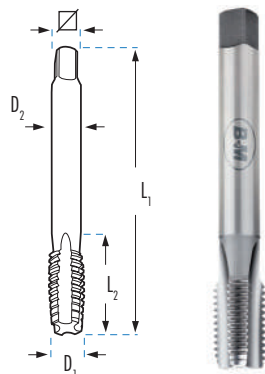

ROSCA CÔNICA INGLESA PARA TUBO

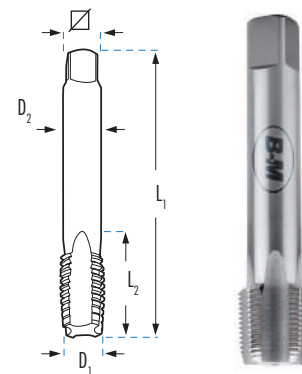

		D1 mm	L1 x L2 x D2 x mm	M1D	€
Rp	1/16-28h.	7,72	D 90 x 16 x 6 x 4,9		
Rp	1/8-28h.	9,73	D 90 x 16 x 7 x 5,5		53,18
Rp	1/4-19h.	13,16	D 100 x 22 x 11 x 9,0		73,46
Rp	3/8-19h.	16,66	D 100 x 22 x 12 x 9,0		87,96
Rp	1/2-14h.	20,95	D 125 x 25 x 16 x 12,0		111,16
Rp	3/4-14h.	26,44	D 140 x 28 x 20 x 16,0		174,07
Rp	1"-11h.	33,25	D 160 x 30 x 25 x 20,0		270,08
Rp	1.1/4-11h.	41,91	D 170 x 30 x 32 x 24,0		
Rp	1.1/2-11h.	46,80	D 190 x 32 x 36 x 29,0		
Rp	2"-11h.	59,61	D 220 x 36 x 45 x 35,0		

		D1 mm	Ø	L1 x L2 x D2 x mm	M1D	€
Rc	1/16-28h.	7,72		D 90 x 14 x 6 x 4		
Rc	1/8-28h.	9,73	8,30	D 90 x 15 x 7 x 5		54,41
Rc	1/4-19h.	13,16	11,00	D 100 x 19 x 11 x 9		78,26
Rc	3/8-19h.	16,66	14,50	D 100 x 21 x 12 x 9		108,76
Rc	1/2-14h.	20,95	18,10	D 125 x 26 x 16 x 12		151,12
Rc	5/8-14h.	22,91	21,00	D 140 x 36 x 18 x 19		243,77
Rc	3/4-14h.	26,44	23,50	D 140 x 28 x 20 x 16		235,69
Rc	7/8-14h.	30,20	28,25	D 160 x 36 x 22 x 18		410,13
Rc	1"-11h.	33,25	29,60	D 160 x 33 x 25 x 20		337,80

NPS (M) ANSI B 1.20.1 60° HSSCo 5% DIN 374 FORMA C

NPT ANSI B 1.20.1 60° HSSCo 5% DIN 374 FORMA C

ROSCA CILÍNDRICA AMERICANA PARA TUBO

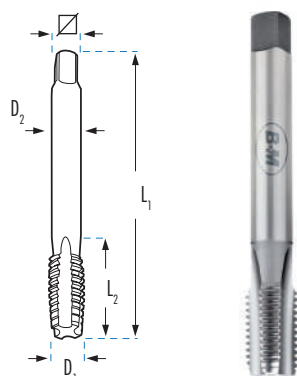

ROSCA CÔNICA AMERICANA PARA TUBO

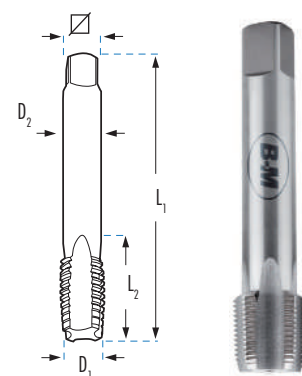

		D1 mm	Ø	L1 x L2 x D2 x mm	M1D	€
NPS	1/8-27h.	10,20	8,90	D 90 x 16 x 7 x 5,5		136,98
NPS	1/4-18h.	13,60	11,70	D 100 x 22 x 11 x 9,0		196,06
NPS	3/8-18h.	17,00	15,00	D 100 x 22 x 12 x 9,0		268,85
NPS	1/2-14h.	21,20	18,60	D 125 x 25 x 16 x 12,0		368,67
NPS	3/4-14h.	26,55	24,00	D 140 x 28 x 20 x 16,0		545,00
NPS	1"-11,5 h.	33,20	30,00	D 160 x 30 x 25 x 20,0		704,79
NPS	1.1/4-11,5h.	41,60		D 170 x 30 x 32 x 24,0		
NPS	1.1/2-11,5h.	47,68		D 190 x 32 x 36 x 29,0		
NPS	2"-11,5h.	59,71		D 220 x 36 x 45 x 35,0		

		D1 mm	Ø	L1 x L2 x D2 x mm	M1D	€
NPT	1/16-27h.	7,89	6,2	D 90 x 14 x 6 x 5		47,66
NPT	1/8-27h.	10,24	8,5	D 90 x 15 x 8 x 6		49,84
NPT	1/4-18h.	13,62	11,0	D 100 x 19 x 11 x 9		64,37
NPT	3/8-18h.	17,05	14,5	D 100 x 21 x 12 x 9		82,74
NPT	1/2-14h.	21,22	17,8	D 125 x 26 x 16 x 12		107,64
NPT	3/4-14h.	26,57	23,0	D 140 x 28 x 20 x 16		166,77
NPT	1"-11,5h.	33,23	29,0	D 160 x 33 x 25 x 20		216,76
NPT	1.1/4-11,5h.	41,98	37,5	D 170 x 36 x 32 x 24		295,95
NPT	1.1/2-11,5h.	48,05	44,0	D 190 x 37 x 36 x 29		466,01
NPT	2"-11,5h.	60,09	56,0	D 220 x 41 x 45 x 35		730,99

MACHOS PARA ROSCAGEM A MÁQUINA HSSCo

NPSF

HSSCo
5%DIN
374FORMA
C

NPTF

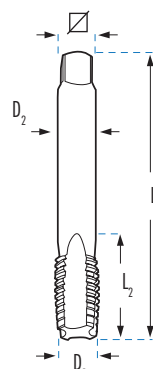
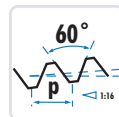
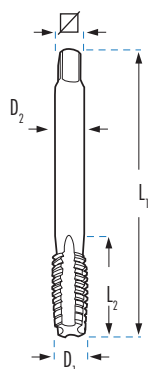
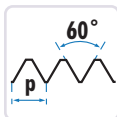
HSSCo
5%DIN
374FORMA
CROSCA PARA TUBO
AMERICANA CILÍNDRICAROSCA PARA TUBO
AMERICANA CÔNICA ESTANQUE

				M1D	
		D1 mm		L1 x L2 x D2 x ∇ mm	€
NPSF	1/8-27h.	10,05	8,75	D 90 x 16 x 7 x 5,5	171,59
NPSF	1/4-18h.	13,33	11,30	D 100 x 22 x 11 x 9,0	236,51
NPSF	3/8-18h.	16,78	14,70	D 100 x 22 x 12 x 9,0	336,46
NPSF	1/2-14h.	20,87	18,20	D 125 x 25 x 16 x 12,0	419,58
NPSF	3/4-14h.	26,23	23,50	D 140 x 28 x 20 x 16,0	686,70
NPSF	1"-11,5h.	32,81	29,50	D 160 x 30 x 25 x 20,0	

				M1D	
		D1 mm		L1 x L2 x D2 x ∇ mm	€
NPTF	1/16-27h.	7,87	6,20	D 90 x 14 x 12,0 x 6	
NPTF	1/8-27h.	10,22	8,50	D 90 x 15 x 12,0 x 7	115,93
NPTF	1/4-18h.	13,58	11,00	D 100 x 21 x 17,5 x 11	162,65
NPTF	3/8-18h.	17,02	14,50	D 110 x 21 x 17,6 x 12	208,94
NPTF	1/2-14h.	21,21	17,80	D 140 x 27 x 22,8 x 16	272,00
NPTF	3/4-14h.	26,56	23,00	D 140 x 27 x 23,0 x 20	421,39

MF

HSSCo
5%TOL
6HFORMA
CDIN
374

PG

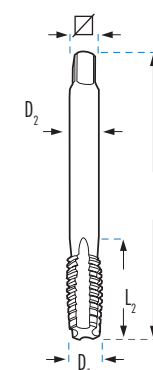
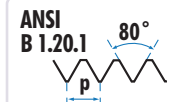
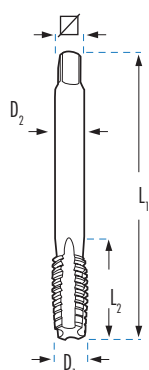
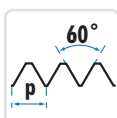
HSSCo
5%DIN
40430FORMA
CROSCA MÉTRICA FINA PARA
TUBO DE CONDUÇÃO
ELÉTRICA EM 60423ROSCA PARA TUBO DE
CONDUÇÃO ELÉTRICA

				M1D	
		D1 mm		L1 x L2 x D2 x ∇ mm	€
MF	12 x 1,50	12	10,5	D 100 x 22 x 9 x 7,0	29,25
MF	16 x 1,50	16	14,5	D 100 x 22 x 12 x 9,0	41,19
MF	20 x 1,50	20	18,5	D 125 x 25 x 16 x 12,0	61,77
MF	25 x 1,50	25	23,5	D 140 x 28 x 18 x 14,5	142,28
MF	32 x 1,50	32	30,5	D 150 x 28 x 22 x 18,0	177,58
MF	40 x 1,50	40	38,5	D 170 x 30 x 32 x 24,0	299,09
MF	50 x 1,50	50	48,5	D 190 x 32 x 36 x 29,0	465,66
MF	63 x 1,50	63	61,5	D 275 x 36 x 50 x 39,0	

				M1D	
		D1 mm		L1 x L2 x D2 x ∇ mm	€
PG	7 - 20h.	12,5	11,50	D 100 x 22 x 9 x 7,0	50,87
PG	9 - 18h.	15,2	14,00	D 100 x 22 x 12 x 9,0	70,46
PG	11 - 18h.	18,6	17,25	D 110 x 25 x 14 x 11,0	91,67
PG	13,5 - 18h.	20,4	19,00	D 125 x 25 x 16 x 12,0	102,94
PG	16 - 18h.	22,5	21,25	D 125 x 25 x 18 x 14,5	121,15
PG	21 - 16h.	28,3	27,00	D 150 x 28 x 22 x 18,0	192,33
PG	29 - 16h.	37,0	35,50	D 170 x 30 x 28 x 22,0	325,13
PG	36 - 16h.	47,0	45,50	D 190 x 32 x 36 x 29,0	528,03
PG	42 - 16h.	54,0	52,50	D 190 x 32 x 40 x 32,0	838,60
PG	48 - 16h.	59,3	58,00	D 220 x 36 x 45 x 35,0	1.022,32

MACHOS PARA ROSCAGEM A MÁQUINA HSSCo

UNx8 HSSCo 5% DIN 374 FORMA C TOL 2B

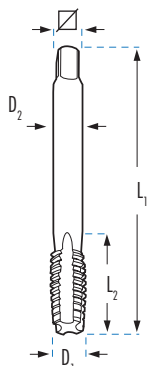
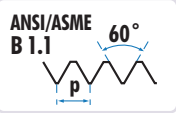

UNEF HSSCo 5% DIN 374 TOL 2B

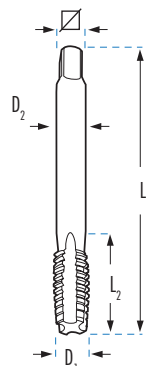
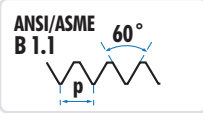

Icon	Ø	D2 mm	L1 x L2 x mm	M1D
				FORMA C
				€
UN 1" 1/8-8h.	25,40	22	180 x 45 x 18	252,89
UN 1" 1/4-8h.	28,50	22	180 x 48 x 18	326,28
UN 1" 3/8-8h.	31,75	28	200 x 56 x 22	370,11
UN 1" 1/2-8h.	35,00	32	200 x 58 x 22	470,91
UN 1" 5/8-8h.	38,10	32	200 x 65 x 24	550,85
UN 1" 3/4-8h.	41,25	36	200 x 50 x 29	671,02
UN 1" 7/8-8h.	44,45	36	225 x 53 x 29	774,04
UN 2"-8h.	47,63	40	225 x 50 x 32	790,89

Icon	Ø	D2 mm	L1 x L2 x mm	M2D	M4D
				FORMA B	35°
				€	€
UNEF 1/4-32h.	5,55	7,0	R 82 x 16 x 5,4	104,64	117,60
UNEF 5/16-32h.	7,15	8,4	R 85 x 21 x 6,1	115,30	129,55
UNEF 3/8-32h.	8,70	7,0	D 95 x 22 x 5,4	115,36	129,62
UNEF 7/16-28h.	10,20	8,0	D 100 x 22 x 6,2	153,12	172,04
UNEF 1/2-28h.	11,80	9,0	D 100 x 22 x 7,0	161,28	181,22
UNEF 9/16-24h.	13,20	12,0	D 100 x 24 x 9,0	202,06	227,04
UNEF 5/8-24h.	14,80	12,0	D 100 x 24 x 9,0	229,94	258,36
UNEF 3/4-20h.	17,80	14,0	D 110 x 27 x 11,0	299,05	336,04
UNEF 7/8-20h.	20,95	18,0	D 125 x 26 x 14,5	321,46	344,42
UNEF 1"-20h.	24,20	18,0	D 140 x 28 x 14,5	491,94	552,74

MACHOS PARA ROSCAGEM A MÁQUINA HSSCo, ROSCA ESQUERDA

M MF HSSCo 5% FORMA C TOL 6H

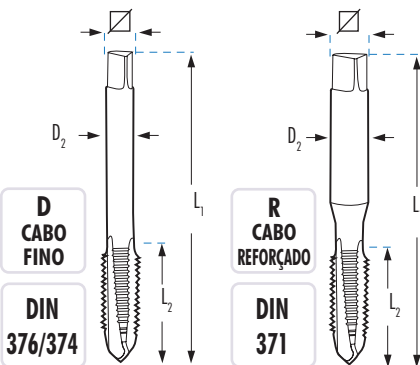
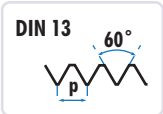

Icon	Ø	L1 x L2 x D2 x mm	M1R1
			FORMA C
			€
M 3x0,50	2,50	R 56 x 11 x 3,5 x 2,7	23,79
M 4x0,70	3,30	R 63 x 13 x 4,5 x 3,4	27,07
M 5x0,80	4,20	R 70 x 16 x 6,0 x 4,9	24,23
M 6x1,00	5,00	R 80 x 17 x 6,0 x 4,9	27,57
M 7x1,00	6,00	R 80 x 17 x 7,0 x 5,5	35,76
M 8x1,25	6,80	R 90 x 20 x 8,0 x 6,2	31,16
M 10x1,50	8,50	R 100 x 22 x 10,0 x 8,0	35,32

CABO FINO		M1D1	
Icon	Ø	FORMA C	
		€	
M 12x1,50	10,50	D 100 x 22 x 9,0 x 7,0	58,51
M 12x1,75	10,20	D 110 x 24 x 9,0 x 7,0	42,17
M 14x1,50	12,50	D 100 x 22 x 11,0 x 9,0	69,68
M 14x2,00	12,00	D 110 x 26 x 11,0 x 9,0	69,22
M 16x1,50	14,50	D 100 x 22 x 12,0 x 9,0	82,38
M 16x2,00	14,00	D 110 x 27 x 12,0 x 9,0	81,46
M 18x1,50	16,50	D 110 x 25 x 14,0 x 11,0	109,07
M 18x2,50	15,50	D 125 x 30 x 14,0 x 11,0	117,20
M 20x1,50	18,50	D 125 x 25 x 16,0 x 12,0	123,54
M 20x2,50	17,50	D 140 x 32 x 16,0 x 12,0	124,76
M 22x2,50	19,50	D 140 x 32 x 18,0 x 14,5	150,97
M 24x2,00	22,00	D 140 x 28 x 18,0 x 14,5	233,33
M 24x3,00	21,00	D 160 x 34 x 18,0 x 14,5	180,73
M 27x3,00	24,00	D 160 x 36 x 20,0 x 16,0	225,60
M 30x2,00	28,00	D 150 x 28 x 22,0 x 18,0	347,42
M 30x3,50	26,50	D 180 x 40 x 22,0 x 18,0	289,11
M 33x3,50	29,50	D 180 x 40 x 25,0 x 20,0	347,42
M 36x4,00	32,00	D 200 x 50 x 28,0 x 22,0	455,97



Consulte outras medidas disponíveis sob demanda.

MACHOS MÁQUINA MÉTRICA NORMA ISO 529

M
MF

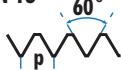
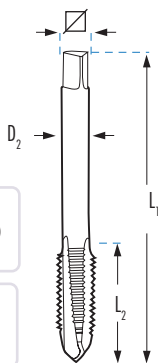
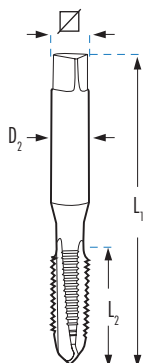
DIN 13

HSSCo
5%ISO
529TOL
6HD
CABO
FINO
ISO
529R
CABO
REFORÇADO
ISO
529

		L1 x L2 x D2 x ∇ mm	M1RISO	M2RISO	M4RISO	M5RISO
			FORMA C	FORMA B	 35° DENTE ALTERNADO AI	€
M 3x0,50	2,50	R 48 x 11 x 3,15 x 2,50	8,58	8,95	10,77	12,81
M 4x0,70	3,30	R 53 x 13 x 4,00 x 3,15	8,58	8,95	10,77	12,81
M 5x0,80	4,20	R 58 x 16 x 5,00 x 4,00	8,58	8,95	10,77	12,81
M 6x1,00	5,00	R 66 x 19 x 6,30 x 5,00	8,58	8,95	11,00	12,81
M 7x1,00	6,00	R 66 x 19 x 7,10 x 5,60		12,73	14,61	
M 8x1,00	7,00	R 69 x 19 x 8,00 x 6,30		17,56	18,02	
M 8x1,25	6,75	R 72 x 22 x 8,00 x 6,30	11,47	11,94	12,35	14,00
M 9x1,25	7,75	R 76 x 20 x 10,00 x 8,00		18,99	21,69	
M 10x1,00	9,00	R 76 x 20 x 10,00 x 8,00		20,14	22,00	
M 10x1,25	8,80	R 76 x 20 x 10,00 x 8,00		24,08	24,85	
M 10x1,50	8,50	R 80 x 24 x 10,00 x 8,00	14,58	15,19	15,92	17,66
CABO FINO			M1DISO	M2DISO	M4DISO	M5DISO
M 12x1,00	11,00	D 84 x 24 x 9,00 x 7,10		27,74	28,42	
M 12x1,25	10,75	D 84 x 24 x 9,00 x 7,10		27,25	28,21	
M 12x1,50	10,50	D 89 x 29 x 9,00 x 7,10		24,31	26,18	
M 12x1,75	10,20	D 89 x 29 x 9,00 x 7,10	18,74	19,52	20,67	26,42
M 14x1,00	13,00	D 90 x 25 x 11,20 x 9,00		34,74	43,22	
M 14x1,25	12,80	D 90 x 25 x 11,20 x 9,00		29,34	36,74	
M 14x1,50	12,50	D 95 x 30 x 12,50 x 9,00		25,78	28,97	
M 14x2,00	12,00	D 95 x 30 x 11,20 x 9,00	22,41	23,34	28,26	
M 16x1,00	15,00	D 95 x 25 x 12,50 x 10,00		44,21	56,89	
M 16x1,25	14,75	D 102 x 32 x 12,50 x 10,00		49,01	63,08	
M 16x1,50	14,50	D 102 x 32 x 14,00 x 10,00		30,94	34,67	
M 16x2,00	14,00	D 102 x 32 x 12,50 x 10,00	27,83	28,98	32,78	
M 18x1,50	16,50	D 104 x 29 x 14,00 x 11,20		40,88	55,86	
M 18x2,50	15,50	D 112 x 37 x 14,00 x 11,20	41,90	43,64	54,56	
M 20x1,50	18,50	D 104 x 29 x 14,00 x 11,20		52,61	64,34	
M 20x2,50	17,50	D 112 x 37 x 14,00 x 11,20	46,83	48,78	60,97	
M 22x2,50	19,50	D 118 x 38 x 16,00 x 12,50	54,15	56,41	70,51	
M 24x3,00	21,00	D 130 x 45 x 18,00 x 14,00	61,17	63,72	79,64	
M 27x3,00	24,00	D 135 x 45 x 20,00 x 16,00	75,33	78,47	98,09	
M 30x3,50	26,50	D 138 x 48 x 20,00 x 16,00	111,92	116,59	145,73	

MACHOS MÁQUINA CURTOS DIN 352

**M
MF**

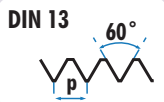

HSS

**HSSCo
5%**

**DIN
352**

**TOL
6H**

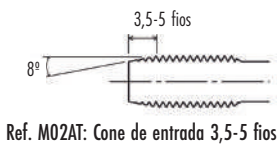
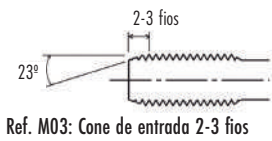

**D
CABO
FINO**

**DIN
352**

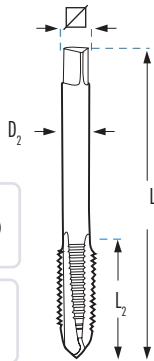

		$L_1 \times L_2 \times D_2 \times \square$ mm	M03	M02AT	M03X	M02DIN	M04DIN
			HSS €	ALTURA ACABADA HSS €	INOX HSSCo €	FORMA B HSS €	35° HSS €
M 3x0,50	2,50	D 40 x 11 x 3,50 x 2,70	7,58	10,43	13,53	9,84	11,85
M 4x0,70	3,30	D 45 x 13 x 4,50 x 3,40	7,57	10,42	13,53	9,84	11,85
M 5x0,80	4,20	D 50 x 16 x 6,00 x 4,90	8,10	11,15	14,09	9,84	11,85
M 6x1,00	5,00	D 50 x 19 x 6,00 x 4,90	8,10	11,15	14,04	9,84	12,11
M 7x1,00	6,00	D 50 x 19 x 6,00 x 4,90	9,86				
M 8x1,00	7,00	D 56 x 18 x 6,00 x 4,90	13,65				
M 8x1,25	6,75	D 56 x 22 x 6,00 x 4,90	9,85	13,57	16,34	13,14	14,68
M 9x1,25	7,75	D 63 x 18 x 7,00 x 5,50	16,14				
M 10x1,00	9,00	D 63 x 18 x 7,00 x 5,50	14,62				
M 10x1,25	8,80	D 70 x 24 x 7,00 x 5,50	14,82				
M 10x1,50	8,50	D 70 x 24 x 7,00 x 5,50	12,15	16,72	21,03	16,71	18,50
M 12x1,00	11,00	D 70 x 20 x 9,00 x 7,00	25,91				
M 12x1,25	10,75	D 70 x 20 x 9,00 x 7,00	25,84				
M 12x1,50	10,50	D 70 x 20 x 9,00 x 7,00	22,02				
M 12x1,75	10,20	D 75 x 29 x 9,00 x 7,00	17,09	23,54	30,11	21,48	24,09
M 14x1,00	13,00	D 70 x 20 x 11,00 x 9,00	40,39				
M 14x1,25	12,80	D 70 x 20 x 11,00 x 9,00	31,55				
M 14x1,50	12,50	D 70 x 20 x 11,00 x 9,00	24,53				
M 14x2,00	12,00	D 80 x 30 x 11,00 x 9,00	18,91	26,03	33,34	25,67	31,09
M 16x1,00	15,00	D 70 x 20 x 12,00 x 9,00	53,58				
M 16x1,25	14,75	D 70 x 20 x 12,00 x 9,00	56,40				
M 16x1,50	14,50	D 70 x 20 x 12,00 x 9,00	30,53				
M 16x2,00	14,00	D 80 x 32 x 12,00 x 9,00	27,06		45,70	31,89	36,05
M 18x1,50	16,50	D 80 x 22 x 14,00 x 11,00	40,22				
M 18x2,50	15,50	D 95 x 40 x 14,00 x 11,00	35,71		62,41	48,01	60,02
M 20x1,50	18,50	D 80 x 22 x 16,00 x 12,00	50,37				
M 20x2,50	17,50	D 95 x 40 x 16,00 x 12,00	40,06		69,27	53,66	67,07
M 22x2,50	19,50	D 100 x 40 x 18,00 x 14,50	53,36			62,03	77,56
M 24x3,00	21,00	D 110 x 50 x 18,00 x 14,50	63,65			70,10	87,61
M 27x3,00	24,00	D 110 x 50 x 20,00 x 16,00	80,48			90,48	99,32
M 30x3,50	26,50	D 125 x 50 x 22,00 x 18,00	103,55			123,93	127,28

MACHOS DE MÁQUINA E CAÇONETES SERIE *Plus* E *Super Plus*



DIN 13

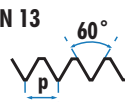

TOL 6H

PARA TRABALHOS DE ALTA PRODUÇÃO
FABRICADOS EM AÇO SINTERIZADO

DIN 22568

TOL 6g

Vc 14 m/min



Plus

Vc 16 m/min



Plus TiN

Vc 17 m/min



Plus TiN

Vc 17 m/min



Plus TiN

Vc 17 m/min



Plus LUBE

Vc 17 m/min



Plus LUBE

Vc 20 m/min



Super Plus ALTiN

Vc 20 m/min



Super Plus ALTiN



ROSCA LAPEADA E
ROMPE AS LIMANHAS



D CABO FINO

DIN 376



R CABO REFORÇADO

DIN 371



QUALIDADE	M2RP		M4RP		M2RT		M4RT		M2RHL		M4RHL		M2RSP		M4RSP		C5P	
	★★	★★	★★★	★★★	★★★★	★★★★	★★★★	★★★★	★★★★	★★★★	★★★★	★★★★	★★★★	★★★★	★★★★			
MATERIAL	HSS PM		HSS PM		HSSCo 5%		HSSCo 5%		HSS PM		HSS PM		HSS V3		HSS V3		HSS	
ACABAMENTO	BRILHANTE		BRILHANTE		TiN		TiN		HARD LUBE		HARD LUBE		ALTiN		ALTiN		BRILHANTE	
ÂNGULO DA HÉLICE	FORMA B		35°		FORMA B		35°		FORMA B		35°		FORMA B		41°			
	L1	L2	D2	L1 x L2 x D2 x ∅		€	€	€	€	€	€	€	€	€	€	€	∅ x L3 mm	€
M 3x0,50	2,50	R	56 x 11 x 3,5 x 2,7	17,59	21,74	23,68	26,17	31,71	34,32	42,61	44,59	25 x 9	32,36					
M 4x0,70	3,30	R	63 x 13 x 4,5 x 3,4	17,97	21,74	24,06	27,29	32,19	34,80	42,61	44,59	25 x 9	32,36					
M 5x0,80	4,20	R	70 x 16 x 6,0 x 4,9	17,97	20,83	24,06	27,29	32,19	34,80	45,00	46,25	25 x 9	32,36					
M 6x1,00	5,00	R	80 x 17 x 6,0 x 4,9	19,76	22,88	27,70	30,00	35,34	36,84	45,00	46,25	25 x 9	32,36					
M 8x1,00	7,00	D	90 x 20 x 6,0 x 4,9	28,20	33,46	39,71	44,19	53,61	59,67			25 x 9	45,13					
M 8x1,25	6,80	R	90 x 20 x 8,0 x 6,2	23,13	26,58	32,38	35,22	44,94	46,88	57,13	60,88	25 x 9	35,10					
M 10x1,00	9,00	D	90 x 16 x 7,0 x 5,5	31,44	39,42	46,39	53,26	62,60	73,96			30 x 10	55,16					
M 10x1,50	8,50	R	100 x 22 x 10,0 x 8,0	27,22	30,94	38,14	41,76	55,73	58,34	68,08	72,63	30 x 10	48,27					
CABO FINO				M2DP	M4DP	M2DT	M4DT	M2DHL	M4DHL	M2DSP	M4DSP							
M 12x1,50	10,50	D	100 x 22 x 9,0 x 7,0	37,30	45,09	50,24	56,56	67,52	77,44			38 x 10	57,34					
M 12x1,75	10,20	D	110 x 24 x 9,0 x 7,0	35,08	41,66	47,02	53,01	58,83	70,61	85,66	92,93	38 x 14	50,63					
M 14x1,50	12,50	D	100 x 22 x 11,0 x 9,0	44,19	55,42	59,08	65,26	79,41	91,07			38 x 10	59,94					
M 14x2,00	12,00	D	110 x 26 x 11,0 x 9,0	43,86	50,84	58,02	63,79	80,25	88,21	87,45	117,75	38 x 14	51,61					
M 16x1,50	14,50	D	100 x 22 x 12,0 x 9,0	55,28	68,16	71,01	81,19	78,41	91,53			45 x 14	82,34					
M 16x2,00	14,00	D	110 x 27 x 12,0 x 9,0	51,58	61,45	66,24	73,23	91,62	101,26	119,37	126,99	45 x 18	69,33					
M 18x2,50	15,50	D	125 x 30 x 14,0 x 11,0	73,11	82,59	90,46	98,69	129,43	137,52	177,19	191,70	45 x 18	69,33					
M 20x2,50	17,50	D	140 x 32 x 16,0 x 12,0	78,99	88,04	103,10	111,07	135,99	154,83	188,84	199,61	45 x 18	69,33					
M 22x2,50	19,50	D	140 x 32 x 18,0 x 14,5	95,56	108,64	116,52	124,72	159,50	174,05			55 x 22	103,06					
M 24x3,00	21,00	D	160 x 34 x 18,0 x 14,5	113,62	130,06	131,29	142,66	179,72	199,07			55 x 22	103,06					

MACHOS DE MÁQUINA HSS-PM PARA TRABALHOS ESPECIAIS

INOX

M

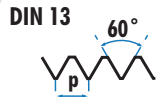

TOL 6H

Vc 6 m/min

Vc 10 m/min

Vc 12 m/min

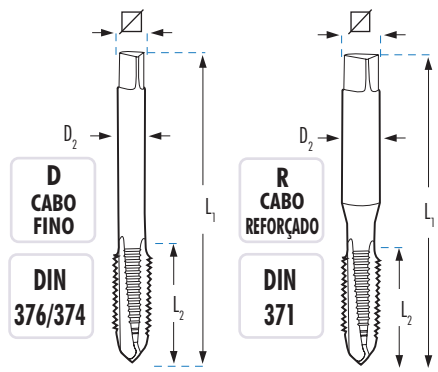

QUALIDADE	M2RX		M4RX		M2RXT		M4RXT		M2RXHL		M4RXHL	
	★★	★★	★★	★★	★★★	★★★	★★★	★★★	★★★★	★★★★	★★★★	★★★★
MATERIAL	HSS PM		HSS PM		HSSCo 5%		HSSCo 5%		HSS PM		HSS PM	
ACABAMENTO	OX		OX		TIN		TIN		HARD LUBE		HARD LUBE	
ÂNGULO DA HÉLICE	FORMA B		FORMA B 35°		FORMA B		FORMA B 35°		FORMA B		FORMA B 35°	
			$L_1 \times L_2 \times D_2 \times \varnothing$ mm		€	€	€	€	€	€	€	€
M 3x0,50	2,50	R	56 x 11 x 3,5 x 2,7	21,02	24,98	24,28	27,47	32,11	37,76			
M 4x0,70	3,30	R	63 x 13 x 4,5 x 3,4	22,07	24,98	25,46	27,92	33,73	38,75			
M 5x0,80	4,20	R	70 x 16 x 6,0 x 4,9	22,07	25,17	25,46	28,34	33,73	39,33			
M 6x1,00	5,00	R	80 x 17 x 6,0 x 4,9	24,18	27,22	26,96	29,63	36,93	41,15			
M 8x1,00	7,00	D	90 x 20 x 6,0 x 4,9	39,04	42,78							
M 8x1,25	6,80	R	90 x 20 x 8,0 x 6,2	26,97	31,01	31,16	34,14	41,23	47,39			
M 10x1,00	9,00	D	90 x 16 x 7,0 x 5,5	40,24	42,96							
M 10x1,50	8,50	R	100 x 22 x 10,0 x 8,0	32,99	36,79	36,44	40,26	50,38	56,20			
CABO FINO												
M 12x1,00	11,00	D	100 x 22 x 9,0 x 7,0	45,63	52,35							
M 12x1,50	10,50	D	100 x 22 x 9,0 x 7,0	46,32	54,77							
M 12x1,75	10,20	D	110 x 24 x 9,0 x 7,0	42,39	49,63	46,61	52,47	66,34	77,66			
M 14x2,00	12,00	D	110 x 26 x 11,0 x 9,0	60,34	69,12	60,72	65,64	88,15	97,61			
M 16x2,00	14,00	D	110 x 27 x 12,0 x 9,0	67,20	79,77	68,92	75,53	98,14	118,06			
M 18x2,50	15,50	D	125 x 30 x 14,0 x 11,0	100,63	113,51	103,90	107,81	157,49	167,97			
M 20x2,50	17,50	D	140 x 32 x 16,0 x 12,0	108,75	119,87	118,63	121,80	167,43	177,36			
M 22x2,50	19,50	D	140 x 32 x 18,0 x 14,5	130,49	137,88	147,26	159,44					
M 24x3,00	21,00	D	160 x 34 x 18,0 x 14,5	137,19	157,47	150,13	163,09					
M 27x3,00	24,00	D	160 x 36 x 20,0 x 16,0	179,71	206,27							
M 30x3,50	26,50	D	180 x 40 x 22,0 x 18,0	229,81	263,78							



- LUBRIFICAÇÃO: **CUT MAGIC XTHICK**.
- Recomenda-se a aplicação do óleo de corte CUT MAGIC XTHICK para otimizar o processo de rosqueamento em Inox, Inconel, Titânio, Duplex, etc...

Ref. ACXT00250

MACHOS *Super Plus* PARA A ROSCAGEM DE LIGAS REFRATÁRIAS

M **DIN 13** **60°** **TOL 6H** **INOX DUPLEX** **Ni** **INC** **Ti**

ESPECIALMENTE RECOMENDADO EM APLICAÇÕES AERONÁUTICAS



				M2RDU	M4RDU	M2RNI	M3RNI	M2RTIT	M3RTIT
QUALIDADE				★★★★	★★★★	★★★★	★★★★	★★★★	★★★★
MATERIAL				HSS V3	HSS V3	HSS PM	HSS PM	HSS PM	HSS PM
ACABAMENTO				TiCN	TiCN	BRILHANTE	BRILHANTE	OX	OX
ÂNGULO DA HÉLICE				FORMA B	41°	FORMA B	15°	FORMA B	15°
				€	€	€	€	€	€
		L1 x L2 x D2 x \square mm							
M	3x0,50	2,50	R 56 x 11 x 3,5 x 2,7	43,21	44,26	80,27	82,03	59,60	65,78
M	4x0,70	3,30	R 63 x 13 x 4,5 x 3,4	43,21	44,53	82,03	84,25	61,46	65,78
M	5x0,80	4,20	R 70 x 16 x 6,0 x 4,9	44,66	45,53	84,92	86,93	63,01	70,07
M	6x1,00	5,00	R 80 x 17 x 6,0 x 4,9	45,89	46,86	85,59	88,01	63,01	71,04
M	8x1,25	6,80	R 90 x 20 x 8,0 x 6,2	64,09	66,82	96,73	99,30	72,81	82,03
M	10x1,50	8,50	R 100 x 22 x 10,0 x 8,0	83,07	85,23	114,92	118,44	90,17	98,85
		CABO FINO		M2DDU	M4DDU	M2DNI	M3DNI	M2DTIT	M3DTIT
M	12x1,75	10,20	D 110 x 24 x 9,0 x 7,0	112,30	121,26	147,82	163,44	113,17	122,81
M	14x2,00	12,00	D 110 x 26 x 11,0 x 9,0						
M	16x2,00	14,00	D 110 x 27 x 12,0 x 9,0	165,14	176,59				
M	18x2,50	15,50	D 125 x 30 x 14,0 x 11,0						
M	20x2,50	17,50	D 140 x 32 x 16,0 x 12,0	244,53	264,13				
M	22x2,50	19,50	D 140 x 32 x 18,0 x 14,5						
M	24x3,00	21,00	D 160 x 34 x 18,0 x 14,5	331,21	336,89				
M	27x3,00	24,00	D 160 x 36 x 20,0 x 16,0	425,51	446,03				
M	30x3,50	26,50	D 180 x 40 x 22,0 x 18,0	502,54	525,85				

MACHOS DE MÁQUINA PARA AÇOS ESTRUTURAIS SUPER MACIOS < DE 450 N/mm²

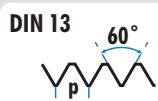

HSSCo
5%

OX

TOL
6H

APLICAÇÕES





ST52

Al

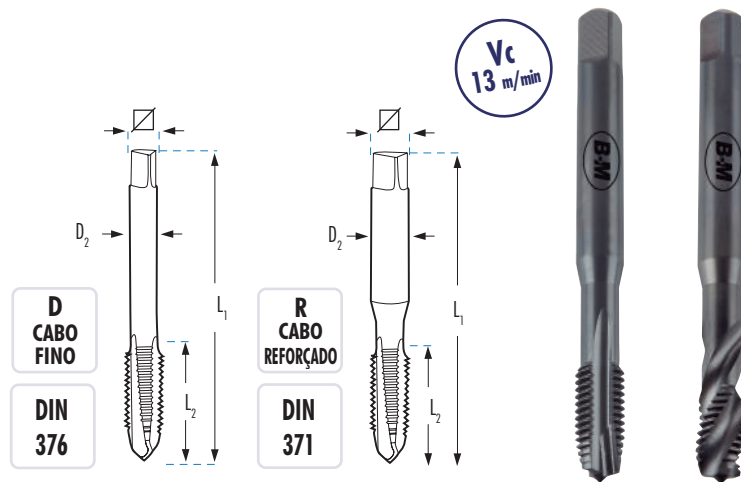
Geometria de corte específica para materiais macios, não gera sobremedida e se encaixa perfeitamente a este tipo de materiais, onde os machos convencionais podem causar sobremedida ao gerar a rosca.



		$L_1 \times L_2 \times D_2 \times \nabla$ mm	M2RSS	M4RSS
			FORMA B	35°
			€	€
M 3 x 0,50	2,50	R 56 x 11 x 3,5 x 2,7	14,97	20,00
M 4 x 0,70	3,30	R 63 x 13 x 4,5 x 3,4	15,67	20,01
M 5 x 0,80	4,20	R 70 x 16 x 6,0 x 4,9	15,69	19,19
M 6 x 1,00	5,00	R 80 x 17 x 6,0 x 4,9	17,21	21,04
M 8 x 1,25	6,80	R 90 x 20 x 8,0 x 6,2	19,31	23,80
M 10 x 1,50	8,50	R 100 x 22 x 10,0 x 8,0	23,78	28,19
CABO FINO			M2DSS	M4DSS
M 12 x 1,75	10,20	D 110 x 24 x 9,0 x 7,0	29,99	36,31
M 14 x 2,00	12,00	D 110 x 26 x 11,0 x 9,0	44,28	52,29
M 16 x 2,00	14,00	D 110 x 27 x 12,0 x 9,0	51,79	63,17
M 18 x 2,50	15,50	D 125 x 30 x 14,0 x 11,0	73,77	81,89
M 20 x 2,50	17,50	D 140 x 32 x 16,0 x 12,0	79,63	90,78
M 22 x 2,50	19,50	D 140 x 32 x 18,0 x 14,5	95,59	106,53
M 24 x 3,00	21,00	D 160 x 34 x 18,0 x 14,5	113,86	129,49
M 27 x 3,00	24,00	D 160 x 36 x 20,0 x 16,0	142,41	159,32
M 30 x 3,50	26,50	D 180 x 40 x 22,0 x 18,0	182,98	204,17

MACHOS DE MÁQUINA HSS-PM PARA TRABALHOS ESPECIAIS

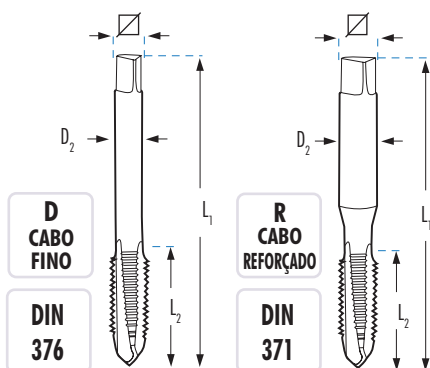
HSS
V3TOL
6HMATERIAIS
DUROSVc
7 m/minVc
9 m/min

		M2RMD	M4RMD	M2RMDTX	M4RMDTX	
QUALIDADE		★★★	★★★	★★★★	★★★★	
MATERIAL		HSS V3	HSS V3	HSS V3	HSS V3	
ACABAMENTO		OX	OX	TINALOX	TINALOX	
ÂNGULO DA HÉLICE		FORMA B	35°	FORMA B	35°	
		€	€	€	€	
M 3x0,50	2,50	R 56 x 11 x 3,5 x 2,7	18,45	20,20	27,06	31,82
M 4x0,70	3,30	R 63 x 13 x 4,5 x 3,4	18,51	20,27	28,43	33,32
M 5x0,80	4,20	R 70 x 16 x 6,0 x 4,9	18,51	21,26	28,43	33,32
M 6x1,00	5,00	R 80 x 17 x 6,0 x 4,9	21,01	21,97	31,14	35,04
M 8x1,25	6,80	R 90 x 20 x 8,0 x 6,2	22,45	25,92	34,76	39,95
M 10x1,50	8,50	R 100 x 22 x 10,0 x 8,0	25,86	29,85	43,98	49,06
CABO FINO		M2DMD	M4DMD	M2DMDTX	M4DMDTX	
M 12x1,75	10,20	D 110 x 24 x 9,0 x 7,0	36,87	42,53	58,58	68,58
M 14x2,00	12,00	D 110 x 26 x 11,0 x 9,0	48,36	50,48	83,35	91,52
M 16x2,00	14,00	D 110 x 27 x 12,0 x 9,0	54,10	61,08	92,84	110,68
M 18x2,50	15,50	D 125 x 30 x 14,0 x 11,0	80,66	86,89	136,50	154,58
M 20x2,50	17,50	D 140 x 32 x 16,0 x 12,0	87,17	91,74	147,53	163,18

MACHOS DE MÁQUINA PARA MATERIAIS TEMPERADOS (HARDOX 450/500)

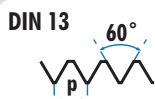

TOL 6H

HSSE

HSS PM

MD

MATERIAIS MUITO DUROS

48 HRc

48-62 HRc

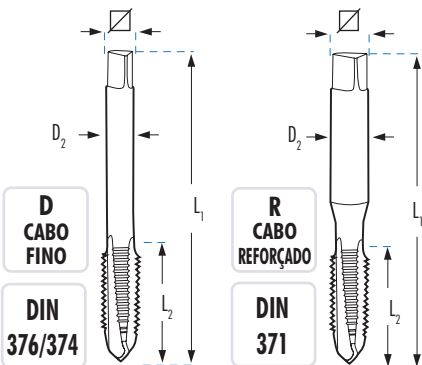

Vc 5 m/min



MD

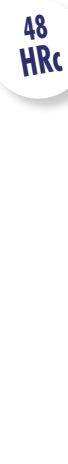

DIN 371 6HX



Metal Duro

MATERIAL	ACABAMENTO	FORMA	M2RC		M3RC		M2HRC		M4HRC		M1RCM		M1RHMC	
			€	€	€	€	€	€	€	€				
M 3 x 0,50	2,50	R 56 x 11 x 3,5 x 2,7	29,52	31,40	32,64	36,56	2,60	47,28	2,60	130,98				
M 4 x 0,70	3,30	R 63 x 13 x 4,5 x 3,4	29,58	33,44	33,90	37,97	3,40	41,59	3,40	130,98				
M 5 x 0,80	4,20	R 70 x 16 x 6,0 x 4,9	29,86	32,68	34,23	38,34	4,30	46,47	4,30	130,98				
M 6 x 1,00	5,00	R 80 x 17 x 6,0 x 4,9	32,28	36,18	35,69	39,97	5,10	59,50	5,10	163,73				
M 8 x 1,25	6,80	R 90 x 20 x 8,0 x 6,2	37,28	42,54	44,37	49,71	6,90	66,00	6,90	184,26				
M 10 x 1,50	8,50	R 100 x 22 x 10,0 x 8,0	44,63	52,70	53,11	55,77	8,60	85,56	8,60	282,73				
CABO FINO			M2DC	M3DC	M2HDC	M4HDC	M1RCM		M1DHMC					
M 12 x 1,75	10,20	D 110 x 24 x 9,0 x 7,0	66,74	79,22	81,07	88,38	10,40	113,20 *	10,40	442,80				
M 14 x 2,00	12,00	D 110 x 26 x 11,0 x 9,0	90,11	105,40	96,14	108,13	12,10	143,12 *	12,10	510,23				
M 16 x 2,00	14,00	D 110 x 27 x 12,0 x 9,0	101,67	121,07	106,89	123,95	14,10	153,09 *	16,10	666,25				
M 18 x 2,50	15,50	D 125 x 30 x 14,0 x 11,0	128,75	140,20	132,32	144,23			15,75	813,95				
M 20 x 2,50	17,50	D 140 x 32 x 16,0 x 12,0	155,93	162,29	156,26	170,33			17,75	1.287,53				
M 22 x 2,50	19,50	D 140 x 32 x 18,0 x 14,5	220,88	230,33										
M 24 x 3,00	21,00	D 160 x 34 x 18,0 x 14,5	226,13	236,63	235,97	257,22								
M 27 x 3,00	24,00	D 160 x 36 x 20,0 x 16,0	236,63	254,48										
M 30 x 3,50	26,50	D 180 x 40 x 22,0 x 18,0	253,31	268,13										

* Cabo Reforçado: M12 - Ø 12 x 9
M14 - Ø 14 x 11
M16 - Ø 16 x 12



- LUBRIFICAÇÃO: **CUT MAGIC XTHICK**.
- Recomenda-se rosar a peça sobre a mesma ferramenta utilizada para a furação previa e na mesma posição, para garantir a coaxialidade entre o macho e o furo previo.

Ref. ACXT00250

HRc	Vc (m/min)
48 Hrc	8 m/min
56 Hrc	6 m/min
62Hrc	3 m/min

MACHOS DE MÁQUINA TODO-O-TERRENO

TODO-O
TERRENOHSSCo
5%

TiN

TOL
6H

APLICAÇÕES

1200
N/mm²

Al

FUNDIÇÃO

Ti

INOX

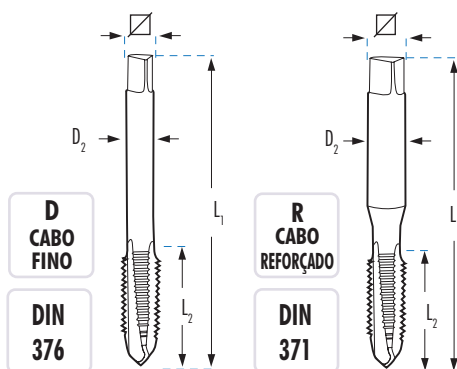
Vc
13 m/min

				M2RD	M4RD
		L1 x L2 x D2 x mm		FORMA B	
				€	€
M 3 x 0,50	2,50	R	56 x 11 x 3,5 x 2,7	27,71	34,64
M 4 x 0,70	3,30	R	63 x 13 x 4,5 x 3,4	29,65	34,64
M 5 x 0,80	4,20	R	70 x 16 x 6,0 x 4,9	31,54	35,88
M 6 x 1,00	5,00	R	80 x 17 x 6,0 x 4,9	32,64	37,24
M 8 x 1,25	6,80	R	90 x 20 x 8,0 x 6,2	38,24	42,49
M 10 x 1,50	8,50	R	100 x 22 x 10,0 x 8,0	44,12	50,34
		CABO FINO		M2DD	M4DD
M 12 x 1,75	10,20	D	110 x 24 x 9,0 x 7,0	55,60	66,19
M 14 x 2,00	12,00	D	110 x 26 x 11,0 x 9,0	72,61	79,79
M 16 x 2,00	14,00	D	110 x 27 x 12,0 x 9,0	81,36	88,06
M 18 x 2,50	15,50	D	125 x 30 x 14,0 x 11,0	127,14	130,38
M 20 x 2,50	17,50	D	140 x 32 x 16,0 x 12,0	129,51	134,36

MACHOS DE MÁQUINA HSSCo PARA TRABALHOS ESPECIAIS

Machos e Caçonetes

Rosa

Al

FUNDIÇÃO

LATÃO

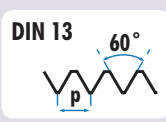

HSSCo
5%

MD

TOL
6H

Vc
18 m/min

Vc
11 m/min

Vc
21 m/min

Vc
16 m/min

Vc
19 m/min

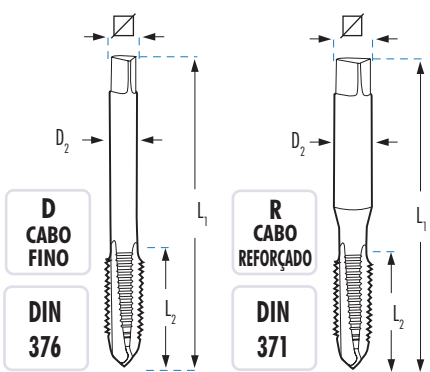

			M5R	M6R	M1RFM	MHM1R	M1RL	M1RLCRN
APLICAÇÃO			Al	Al	FUNDIÇÃO	FUNDIÇÃO	LATÃO	LATÃO
MATERIAL			HSSCo 5%	HSSCo 5%	HSSCo 5%	MD	HSSCo 5%	HSSCo 5%
ACABAMENTO			BRILHANTE	BRILHANTE	OX	BRILHANTE	BRILHANTE	CrN
FORMA			DENTE ALTERNADO	2 CANAIS	FORMA C	FORMA C	FORMA C	FORMA C
		L1 x L2 x D2 x \square mm	€	€	€	€	€	€
M 3x0,50	2,50	R 56 x 11 x 3,5 x 2,7	23,91	25,65	16,92	85,74	20,25	23,01
M 4x0,70	3,30	R 63 x 13 x 4,5 x 3,4	24,05	25,65	17,48	85,74	21,50	25,36
M 5x0,80	4,20	R 70 x 16 x 6,0 x 4,9	23,91	26,20	17,48	85,74	21,50	25,45
M 6x1,00	5,00	R 80 x 17 x 6,0 x 4,9	25,20	28,33	19,86	97,80	23,56	27,79
M 8x1,25	6,80	R 90 x 20 x 8,0 x 6,2	30,17	33,95	22,24	109,20	26,87	33,79
M 10x1,50	8,50	R 100 x 22 x 10,0 x 8,0	36,37	40,14	25,44	136,86	32,32	41,12
CABO FINO			M5D	M6D	M1DFM	MHM1D	M1DL	M1DLCRN
M 12x1,75	10,20	D 110 x 24 x 9,0 x 7,0	46,23	50,45	32,60	190,92	38,42	50,63
M 14x2,00	12,00	D 110 x 26 x 11,0 x 9,0	83,72	87,13	53,59	297,42	47,17	61,70
M 16x2,00	14,00	D 110 x 27 x 12,0 x 9,0	91,25	98,81	63,05	353,84	54,26	68,99
M 18x2,50	15,50	D 125 x 30 x 14,0 x 11,0			88,20	433,74	71,17	87,37
M 20x2,50	17,50	D 140 x 32 x 16,0 x 12,0			88,55	525,24	79,88	97,27



- LUBRIFICAÇÃO: **CUT MAGIC ALUMINIUM**.
- Recomenda-se a aplicação do óleo de corte CUT MAGIC ALUMINIUM para otimizar o processo de rosqueamento em alumínio e as suas fundições.

Ref. ACAL00250

MACHOS DE MÁQUINA PARA ROSCAGEM POR LAMINAÇÃO



HSSCo
5%

HSSCo
8%

TOL
6HX

APLICAÇÕES



Plus

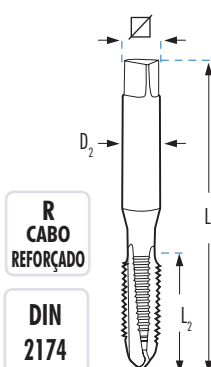

		M07R	M07RT	M07RCR	M07RCCR	M09RCCR	M07RXTCR
APLICAÇÃO		LAMINAÇÃO	LAMINAÇÃO	LAMINAÇÃO	LAMINAÇÃO	LAMINAÇÃO	LAMINAÇÃO
MATERIAL		HSSCo 5%	HSSCo 5%	HSSCo 5%	HSSCo 5%	HSSCo 8%	HSSCo 5%
ACABAMENTO		OX	TiN	OX	TiCN	TiCN	TiN
FORMA							
	$L1 \times L2 \times D2 \times \square$ mm	€	€	€	€	€	€
M 3x0,50	2,75 R 56 x 11 x 3,5 x 2,7	33,82	36,72	37,22	46,70	112,36	83,79
M 3,5x0,60	3,20 R 56 x 11 x 3,5 x 2,7	35,55	40,49	38,45	49,43		
M 4x0,70	3,65 R 63 x 13 x 4,5 x 3,4	33,82	38,29	37,22	48,71	113,78	83,79
M 5x0,80	4,60 R 70 x 16 x 6,0 x 4,9	33,82	38,29	37,22	48,71	115,29	90,43
M 6x1,00	5,50 R 80 x 17 x 6,0 x 4,9	36,52	40,47	40,16	51,48	117,12	90,43
M 8x1,25	7,40 R 90 x 20 x 8,0 x 6,2	42,56	53,41	46,82	67,97	129,92	108,22
M 10x1,50	9,30 R 100 x 22 x 10,0 x 8,0	47,33	59,89	52,08	74,80	155,12	132,12

		M07D	M07DT	M07DCR	M07DCCR	M09DCCR	M07DXTCR
CABO FINO							
M 12x1,75	11,20 D 110 x 24 x 9,0 x 7,0	55,79	78,32	59,09	85,66	183,62	172,05
M 14x2,00	13,05 D 110 x 26 x 11,0 x 9,0	100,57	123,69	104,48	139,06	228,52	247,51
M 16x2,00	15,05 D 110 x 27 x 12,0 x 9,0	118,06	139,31	122,63	147,21	314,30	251,80
M 18x2,50	16,80 D 125 x 30 x 14,0 x 11,0	135,48	166,58	140,72	173,94	372,40	
M 20x2,50	18,80 D 140 x 32 x 16,0 x 12,0	178,51	252,17	185,43	264,43	412,29	

MACHOS DE MÁQUINA HSSCo TOLERÂNCIAS ESPECIAIS E SOBREMEDIDAS

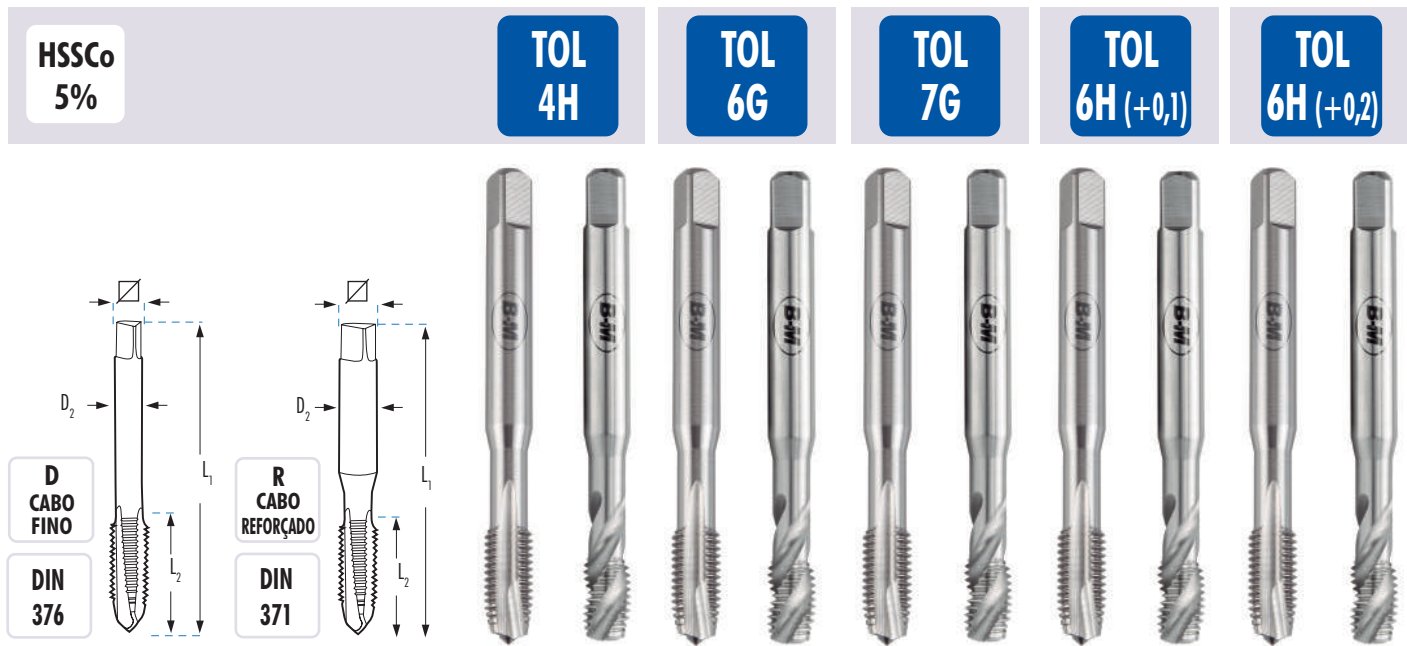

		M2R4H	M4R4H	M2R6G	M4R6G	M2R7G	M4R7G	M2R+0,1	M4R+0,1	M2R+0,2	M4R+0,2	
		TOL 4H	TOL 4H	TOL 6G	TOL 6G	TOL 7G	TOL 7G	TOL 6H (+0,1)	TOL 6H (+0,1)	TOL 6H (+0,2)	TOL 6H (+0,2)	
		HSSCo 5%	HSSCo 5%	HSSCo 5%	HSSCo 5%	HSSCo 5%	HSSCo 5%	HSSCo 5%	HSSCo 5%	HSSCo 5%	HSSCo 5%	
		BRILHANTE	BRILHANTE	BRILHANTE	BRILHANTE	BRILHANTE	BRILHANTE	BRILHANTE	BRILHANTE	BRILHANTE	BRILHANTE	
		FORMA B	FORMA B 35°	FORMA B	FORMA B 35°	FORMA B	FORMA B 35°	FORMA B	FORMA B 35°	FORMA B	FORMA B 35°	
L1 x L2 x D2 x Ø mm		€	€	€	€	€	€	€	€	€	€	
M 3x0,50	2,50	R 56 x 11 x 3,5 x 2,7	23,14	28,61	16,98	20,20	23,14	28,61	23,89	31,87	27,41	33,94
M 4x0,70	3,30	R 63 x 13 x 4,5 x 3,4	23,68	28,61	16,98	20,20	23,68	28,61	24,45	31,87	28,04	33,94
M 5x0,80	4,20	R 70 x 16 x 6,0 x 4,9	23,68	27,42	16,98	19,82	23,68	27,42	24,45	30,52	28,04	32,49
M 6x1,00	5,00	R 80 x 17 x 6,0 x 4,9	26,02	30,08	18,28	21,77	26,02	30,08	26,85	33,50	30,82	35,66
M 8x1,00	7,00	D 90 x 20 x 6,0 x 4,9			35,60	39,36						
M 8x1,25	6,75	R 90 x 20 x 8,0 x 6,2	29,14	34,35	21,25	25,52	29,14	34,35	30,08	38,22	34,52	40,71
M 10x1,00	9,00	D 90 x 16 x 7,0 x 5,5			42,04	48,93						
M 10x1,50	8,50	R 100 x 22 x 10,0 x 8,0	35,83	40,77	26,15	29,18	35,83	40,77	37,01	45,33	42,48	48,26
CABO FINO		M2D4H	M4D4H	M2D6G	M4D6G	M2D7G	M4D7G	M2D+0,1	M4D+0,1	M2D+0,2	M4D+0,2	
M 12x1,50	10,50	D 100 x 22 x 9,0 x 7,0		76,60	90,81							
M 12x1,75	10,20	D 110 x 24 x 9,0 x 7,0	46,20	54,85	34,48	41,54	46,20	54,85	46,35	58,76	52,66	62,57
M 14x2,00	12,00	D 110 x 26 x 11,0 x 9,0		42,36	50,89			75,61	93,53	85,92	99,61	
M 16x2,00	14,00	D 110 x 27 x 12,0 x 9,0		52,35	61,47			88,92	113,03	101,08	120,37	
M 18x2,50	15,50	D 125 x 30 x 14,0 x 11,0		73,83	76,10			134,46	152,24	143,18	162,11	
M 20x2,50	17,50	D 140 x 32 x 16,0 x 12,0		76,25	87,48			145,29	161,99	154,71	172,50	



4H.- Para roscas muito precisas. Ajuste mais exato.
 6G.- Para roscas com revestimentos. Espessuras entre 20 - 40 µ
 7G.- Para roscas com revestimentos. Espessuras entre 40 - 50 µ
 6H. (+0,1)- Para obter roscas com sobremedidas ou para compensar deformações de tratamentos térmicos.
 6H. (+0,2)- Rosca de perfil completo, para terminar o diâmetro exterior da rosca.

MACHOS DE MÁQUINA EXTRA-LONGOS HSSCo

FORMA
BHSSCo
5%

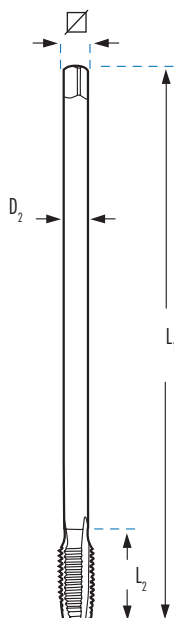
BRILHANTE



TOL
6HR
CABO
REFORÇADODIN
371D
CABO
FINODIN
376

					M2L
				L1 x L2 x D2 x 	FORMA B €
M2LM03X0,50	M 3x0,50	2,50	R	100 x 10 x 3,5 x 2,7	38,63
M2LM04X0,70	M 4x0,70	3,30	R	120 x 12 x 4,5 x 3,4	39,48
M2LM05X0,80	M 5x0,80	4,20	R	140 x 14 x 6,0 x 4,9	39,48
M2LM06X1,00-120	M 6x1,00	5,00	R	120 x 16 x 6,0 x 4,9	41,67
M2LM06X1,00	M 6x1,00	5,00	R	160 x 16 x 6,0 x 4,9	43,38
M2LM07X1,00	M 7x1,00	6,00	R	160 x 17 x 7,0 x 5,5	49,27
M2LM08X1,25-150	M 8x1,25	6,80	R	150 x 18 x 8,0 x 6,2	49,34
M2LM08X1,25	M 8x1,25	6,80	R	180 x 18 x 8,0 x 6,2	50,86
				CABO FINO	M2L-D
M2LM06X1,00D	M 6x1,00	5,00	D	160 x 16 x 4,5 x 3,4	45,03
M2LM08X1,25D	M 8x1,25	6,80	D	180 x 18 x 6,2 x 5,0	52,84
M2LM10X1,50-150	M 10x1,50	8,50	D	150 x 20 x 7,0 x 5,5	58,13
M2LM10X1,50	M 10x1,50	8,50	D	200 x 20 x 7,0 x 5,5	62,61
M2LM12X1,75-150	M 12x1,75	10,20	D	150 x 22 x 8,5 x 6,5	72,11
M2LM12X1,75	M 12x1,75	10,20	D	220 x 22 x 8,5 x 6,5	77,04
M2LM14X2,00	M 14x2,00	12,00	D	220 x 25 x 10,5 x 8,0	119,55
M2LM16X2,00	M 16x2,00	14,00	D	220 x 28 x 12,5 x 10,0	140,64
M2LM18X2,50	M 18x2,50	15,50	D	250 x 32 x 14,0 x 11,0	255,90
M2LM20X2,50	M 20x2,50	17,50	D	250 x 32 x 16,0 x 12,0	276,57
M2LM22X2,50	M 22x2,50	19,50	D	250 x 35 x 18,0 x 14,5	315,32
M2LM24X3,00	M 24x3,00	21,00	D	250 x 38 x 18,0 x 14,5	385,57

HSSCo
5%

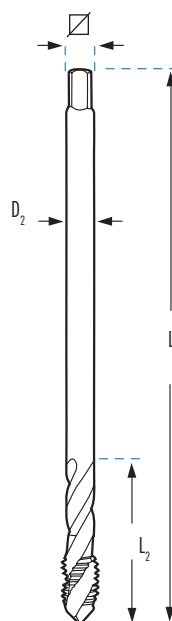
BRILHANTE

TOL
6HR
CABO
REFORÇADODIN
371D
CABO
FINODIN
376

					M4L
				L1 x L2 x D2 x 	FORMA B €
M4LM03X0,50	M 3x0,50	2,50	R	100 x 10 x 3,5 x 2,7	47,80
M4LM04X0,70	M 4x0,70	3,30	R	120 x 12 x 4,5 x 3,4	47,80
M4LM05X0,80	M 5x0,80	4,20	R	140 x 14 x 6,0 x 4,9	45,79
M4LM06X1,00-120	M 6x1,00	5,00	R	120 x 16 x 6,0 x 4,9	47,21
M4LM06X1,00	M 6x1,00	5,00	R	160 x 16 x 6,0 x 4,9	50,23
M4LM07X1,00	M 7x1,00	6,00	R	160 x 17 x 7,0 x 5,5	57,03
M4LM08X1,25-150	M 8x1,25	6,80	R	150 x 18 x 8,0 x 6,2	57,86
M4LM08X1,25	M 8x1,25	6,80	R	180 x 18 x 8,0 x 6,2	61,04
				CABO FINO	M4L-D
M4LM06X1,00D	M 6x1,00	5,00	D	160 x 16 x 4,5 x 3,4	52,19
M4LM08X1,25D	M 8x1,25	6,80	D	180 x 18 x 6,2 x 5,0	62,15
M4LM10X1,50-150	M 10x1,50	8,50	D	150 x 20 x 7,0 x 5,5	65,48
M4LM10X1,50	M 10x1,50	8,50	D	200 x 20 x 7,0 x 5,5	70,74
M4LM12X1,75-150	M 12x1,75	10,20	D	150 x 22 x 8,5 x 6,5	80,18
M4LM12X1,75	M 12x1,75	10,20	D	220 x 22 x 8,5 x 6,5	91,51
M4LM14X2,00	M 14x2,00	12,00	D	220 x 25 x 10,5 x 8,0	133,96
M4LM16X2,00	M 16x2,00	14,00	D	220 x 28 x 12,5 x 10,0	194,13
M4LM18X2,50	M 18x2,50	15,50	D	250 x 32 x 14,0 x 11,0	289,75
M4LM20X2,50	M 20x2,50	17,50	D	250 x 32 x 16,0 x 12,0	308,37
M4LM22X2,50	M 22x2,50	19,50	D	250 x 35 x 18,0 x 14,5	345,44
M4LM24X3,00	M 24x3,00	21,00	D	250 x 38 x 18,0 x 14,5	393,79

MACHO PARA PORCAS DE ROSCA MÉTRICA DIN 357



HSSCo
5%

BRILHANTE

TOL
6H

DIN
357

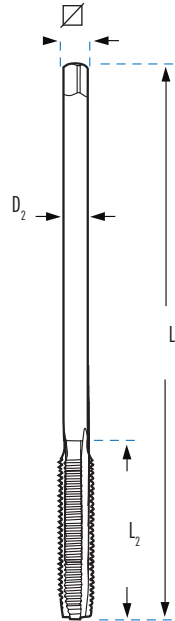

			MTU	
		L1 x L2 x D2 x \square mm	FORMA A	€
M	3x0,50**	2,50 D 70 x 22 x 2,2		25,34
M	4x0,70	3,30 D 90 x 25 x 2,8 x 2,1		25,34
M	5x0,80	4,20 D 100 x 28 x 3,5 x 2,7		25,34
M	6x1,00	5,00 D 110 x 32 x 4,5 x 3,4		25,34
M	8x1,25	6,80 D 125 x 40 x 6,0 x 4,9		30,54
M	10x1,50	8,50 D 140 x 45 x 7,0 x 5,5		29,85
M	12x1,75	10,20 D 180 x 50 x 9,0 x 7,0		36,15
M	14x2,00	12,00 D 200 x 56 x 11,0 x 9,0		57,13
M	16x2,00	14,00 D 200 x 63 x 12,0 x 9,0		70,73
M	18x2,50	15,50 D 220 x 63 x 14,0 x 11,0		95,15
M	20x2,50	17,50 D 250 x 70 x 16,0 x 12,0		134,33*
M	22x2,50	19,50 D 280 x 80 x 18,0 x 14,5		164,81*
M	24x3,00	21,00 D 280 x 80 x 18,0 x 14,5		224,25*

** Cabo cilíndrico.

*Até o fim das existências

MACHO DE MÁQUINA ROSCA TRAPEZOIDAL HSS

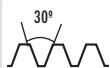

HSS

BRILHANTE



DIN
103

TOL
7H

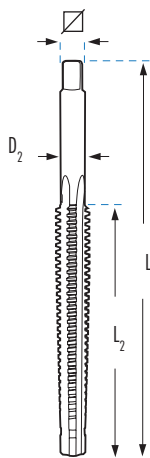

			MRTM	
		L1 x L2 x D2 x \square mm	€	
Tr	14 x 3	11,25 160 x 105 x 10,5 x 8,0	598,95	
Tr	16 x 4	12,25 205 x 110 x 11,5 x 9,0	623,53	
Tr	18 x 4	14,25 215 x 120 x 13,0 x 10,0	657,30	
Tr	20 x 4	16,25 230 x 130 x 15,0 x 12,0	660,38	
Tr	22 x 5	17,25 270 x 165 x 16,0 x 12,0	869,25	
Tr	24 x 5	19,25 280 x 165 x 18,0 x 14,5	985,98	
Tr	26 x 5	21,25 290 x 170 x 20,0 x 16,0	1.020,18	
Tr	28 x 5	23,25 300 x 180 x 22,0 x 18,0	1.155,64	
Tr	30 x 6	24,25 345 x 200 x 23,0 x 18,0	1.329,98	

BROCA MACHO HSSCo

HSSCo
5%

BRILHANTE

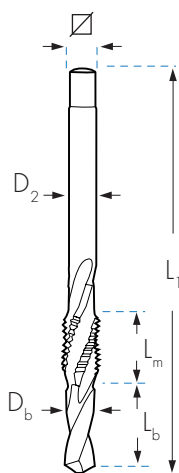
TOL
6HR
CABO
REFORÇADODIN
371D
CABO
FINODIN
376

								M8M
		Lb mm	Lm mm	L1 mm	Db mm	D2 mm	∅ mm	€
M 3x0,50	R	9,0	12,5	62,0	2,5	3,5	2,7	38,84
M 4x0,70	R	10,0	16,0	66,0	3,30	4,5	3,4	38,84
M 5x0,80	R	12,5	18,0	75,5	4,20	6,0	4,9	40,36
M 6x1,00	R	14,0	20,0	81,0	5,00	6,0	4,9	44,57
M 8x1,00	R	20,0	14,0	91,0	7,00	6,0	4,9	52,32
M 8x1,25	R	20,0	14,0	91,0	6,75	8,0	6,2	50,25

CABO FINO

M 8x1,25	D	20,0	14,0	91,0	6,75	6,0	4,9	54,29
M 10x1,00	D	20,0	15,0	95,0	9,00	7,0	5,5	64,94
M 10x1,50	D	25,0	18,0	105,0	8,50	7,0	5,5	68,93
M 12x1,50	D	24,0	18,0	110,0	10,50	9,0	7,0	75,23
M 12x1,75	D	28,0	20,0	118,0	12,50	11,0	9,0	74,79
M 14x1,50	D	28,0	20,0	118,0	12,50	11,0	9,0	119,05
M 14x2,00	D	28,0	22,0	130,0	12,00	11,0	9,0	135,41
M 16x2,00	D	36,0	24,0	139,0	14,00	12,0	9,0	178,09
M 18x2,50	D	40,0	26,0	151,0	15,50	14,0	11,0	259,75
M 20x2,50	D	45,0	30,0	168,0	17,50	16,0	2,0	373,02

Nota: nunca use a broca-macho em furos cegos ou passantes com mais profundidade do que Lb.

BROCA MACHO ESCAREADOR HSSCo STEP CUT

NEW

HSSCo
5%



BRILHANTE

TOL
6HD
CABO
FINO

1/4"

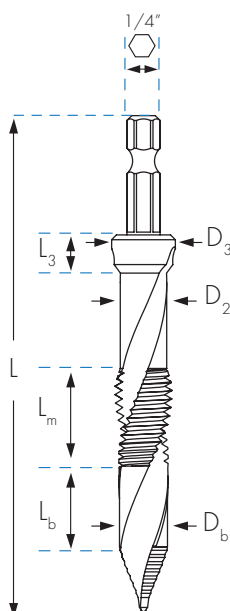
STEP CUT



									MTKM	
		Lb mm	Lm mm	L3 mm	L mm	Db mm	D2 mm	D3 mm	∅ mm	€
M 3x0,50	D	7,0	6,0	6,0	57,0	2,5	2,2	7,3	1/4"	28,21
M 4x0,70	D	7,0	8,5	6,0	62,0	3,3	3,0	7,3	1/4"	28,21
M 5x0,80	D	9,0	10,0	6,0	69,0	4,2	3,7	7,3	1/4"	29,44
M 6x1,00	D	10,0	12,0	6,0	73,0	5,0	4,5	7,3	1/4"	30,66
M 8x1,25	D	12,0	16,0	6,0	87,0	6,8	6,3	9,4	1/4"	42,38
M 10x1,50	D	14,0	20,0	6,0	96,0	8,5	8,0	11,4	1/4"	51,14
M 12x1,75	D	16,0	24,0	8,0	112,0	10,3	9,8	13,4	1/4"	56,36

Nota: nunca use a broca-macho escareador em furos cegos ou passantes com mais profundidade do que Lb.

PASTILHAS PARA ROSCAGEM DE EXTERIOR

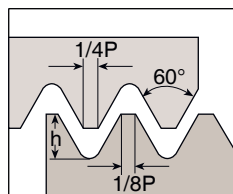
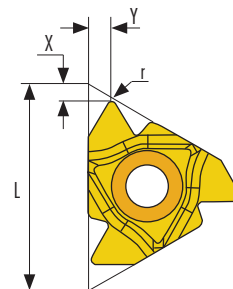
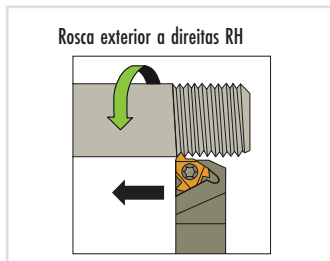
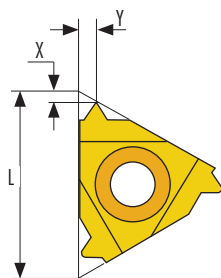

Norma: R262 (DIN 13)
Tolerância classe: 6g/6H

Perfil Total

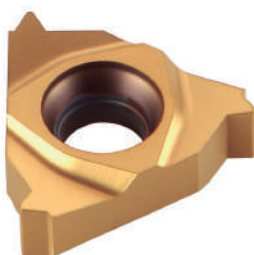
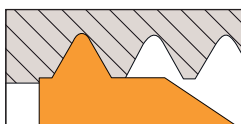

Perfil Parcial

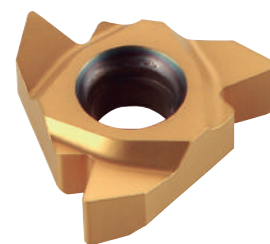
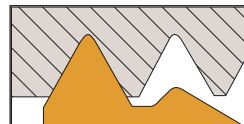

Rosca de perfil completo, para terminar o diâmetro exterior da rosca. Utilizaremos uma pastilha diferente para cada passo.

Não termina o diâmetro exterior da rosca.

A mesma pastilha pode ser utilizada para uma gama de diferentes passos, que tenham o mesmo ângulo de rosca.

PERFIL TOTAL 60°

ROSCAGEM EXTERIOR	L	PASSO	h	X	Y	€
PRE-16-075		0,75	0,46	0,6	0,6	26,84*
PRE-16-100		1,00	0,61	0,7	0,7	26,84*
PRE-16-125		1,25	0,77	0,8	0,9	26,84*
PRE-16-150	16	1,50	0,92	0,8	1	26,84*
PRE-16-175		1,75	1,07	0,9	1,2	26,84*
PRE-16-200		2,00	1,23	1	1,3	26,84*
PRE-16-250		2,50	1,53	1,1	1,5	26,84*
PRE-16-300		3,00	1,84	1,2	1,6	26,84*

*Até o fim das existências.

PERFIL PARCIAL 60°

ROSCAGEM EXTERIOR	L	FAIXAS MÉTRICAS	FAIXAS POLEGADAS	r	X	Y	€
PPRE-16-150	16	0,50-1,50	48 - 16	0,05	0,80	0,90	26,84*

*Até o fim das existências.

PORTA-FERRAMENTAS PARA ROSCAGEM DE EXTERIORES

ROSCAGEM EXTERIOR	H1=H=B=F	L1	L2	€
PEXT-25-16	25	153	30	196,21*

*Até o fim das existências.

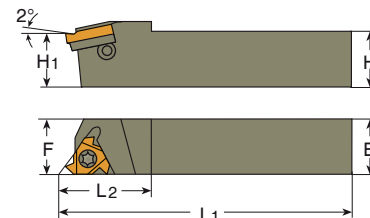

FÓRMULA MATEMÁTICA PARA OBTER A VELOCIDADE DE GIRO DA PEÇA (RPM)

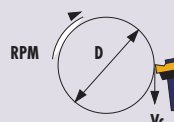

$$RPM = \frac{1000 \times Vc}{\pi \times D}$$

RPM: revoluções por minuto

Vc: velocidade de corte (m/min)

D: diâmetro da peça (mm)

As RPMs obtêm-se em função de Vc e D

AÇO BAIXA LIGA 70 kg/mm ²	Vc	25	ALUMÍNIO	Vc	50
	m/min			m/min	
AÇO TRATADO 120 kg/mm ²	Vc	13	TITÂNIO	Vc	18
	m/min			m/min	
INOXIDÁVEL	Vc	11	FUNDIÇÃO	Vc	25
	m/min			m/min	
			LATÃO	Vc	50
				m/min	

PASTILHAS PARA ROSCAGEM DE INTERIORES

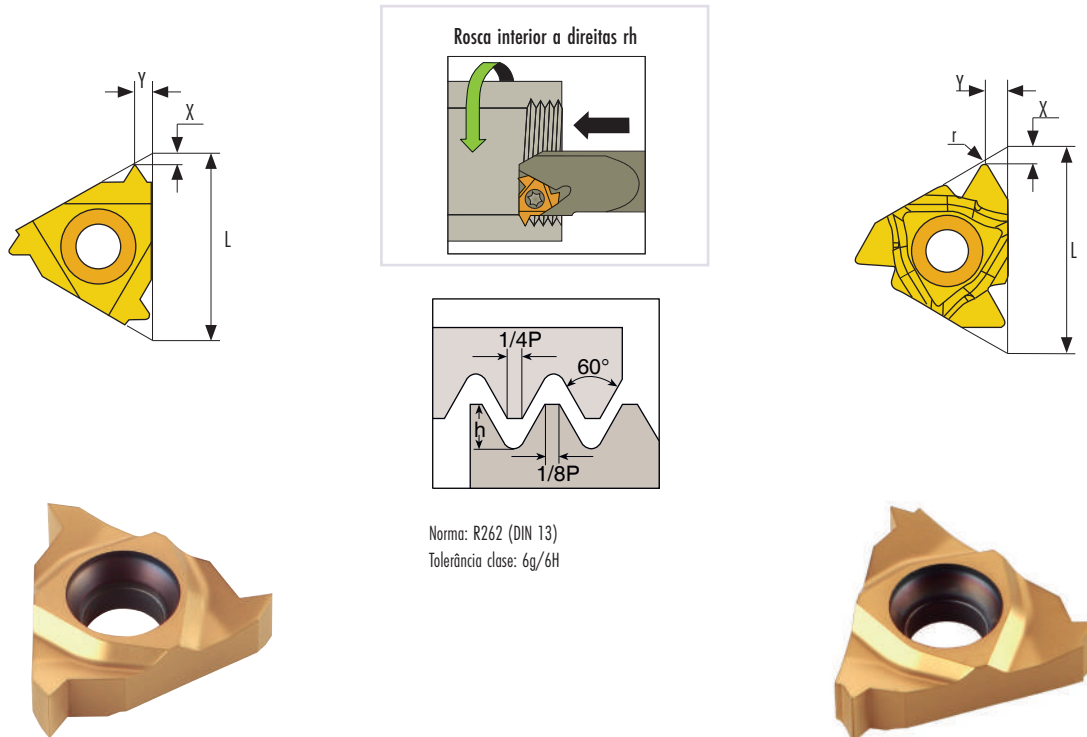

Norma: R262 (DIN 13)
Tolerância classe: 6g/6H

PERFIL TOTAL 60°

ROSCAGEM INTERIOR	L	PASSO	h	X	Y	€
PRI-16-075	16	0,75	0,43	0,6	0,6	26,84*
PRI-16-100		1,00	0,58	0,6	0,7	26,84*
PRI-16-125		1,25	0,72	0,8	0,9	26,84*
PRI-16-150		1,50	0,87	0,8	1,0	26,84*
PRI-16-175		1,75	1,01	0,9	1,2	26,84*
PRI-16-200		2,00	1,15	1,0	1,3	26,84*
PRI-16-250		2,50	1,44	1,1	1,5	26,84*
PRI-16-300		3,00	1,73	1,1	1,5	26,84*

*Até o fim das existências.

PERFIL PARCIAL 60°

ROSCAGEM INTERIOR	L	FAIXAS MÉTRICAS	FAIXAS POLEGADAS	r	X	Y	€
PPRI-16-150	16	0,50-1,50	48 - 16	0,05	0,80	0,90	26,84*
PPRI-16-300		1,75-3,00	14 - 8	0,16	1,20	1,70	26,84*

*Até o fim das existências.

PORTA-FERRAMENTAS PARA ROSCAGEM DE INTERIORES

ROSCAGEM INTERIOR	L	L1	D	D1	A	Ø MÍN. AGUJERO	€
PINT-25-16	200	45	25	24,6	22,6	29	236,46*

*Até o fim das existências.

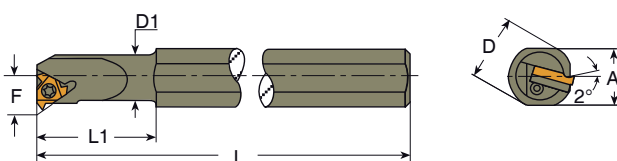

MACHOS PARA MÁQUINA HSSCo EM ESTOJOS METÁLICOS

USO GERAL

HSSCo 5%

Machos e Caçonetes

Rosa



Ref. JM6



Ref. JM2



Ref. JM8



Ref. JM4

CONTEÚDO

	FORMA C	FORMA B	15°	35°	HSS	HSSCo 5% €
JM5	M3 - M4 - M5 - M6 M8 - M10 - M12	-	-	-	-	111,81
JM1	M3 - M4 - M5 - M6 M8 - M10 - M12	-	-	-	2.5/3.3/4.2/5.0/6.8/8.5/10.2 mm	133,74
JM6	-	M3 - M4 - M5 - M6 M8 - M10 - M12	-	-	-	119,13
JM2	-	M3 - M4 - M5 - M6 M8 - M10 - M12	-	-	2.5/3.3/4.2/5.0/6.8/8.5/10.2 mm	133,98
JM7	-	-	M3 - M4 - M5 - M6 M8 - M10 - M12	-	-	148,42
JM3	-	-	M3 - M4 - M5 - M6 M8 - M10 - M12	-	2.5/3.3/4.2/5.0/6.8/8.5/10.2 mm	177,35
JM8	-	-	-	M3 - M4 - M5 - M6 M8 - M10 - M12	-	150,98
JM4	-	-	-	M3 - M4 - M5 - M6 M8 - M10 - M12	2.5/3.3/4.2/5.0/6.8/8.5/10.2 mm	175,46



MACHOS DE MÁQUINA EM ESTOJOS METÁLICOS

Plus





Ref. JMPT2

CONTEÚDO

	FORMA B	BRILHANTE	 35°	BRILHANTE	 HSSCo 5%	HSS PM €		TiN €
JMP6	M3 - M4 - M5 - M6 M8 - M10 - M12		-		-	124,14	JMPT6	179,05
JMP2	M3 - M4 - M5 - M6 M8 - M10 - M12		-		2.5/3.3/4.2/5.0/6.8/8.5/10.2 mm	162,80	JMPT2	217,85
JMP8	-		M3 - M4 - M5 - M6 M8 - M10 - M12		-	179,05	JMPT8	197,20
JMP4	-		M3 - M4 - M5 - M6 M8 - M10 - M12		2.5/3.3/4.2/5.0/6.8/8.5/10.2 mm	217,85	JMPT4	236,13



INOX

CONTEÚDO

	FORMA B	OX	 35°	OX	 HSSCo 5%	HSS PM €		TiN €
JMX6	M3 - M4 - M5 - M6 M8 - M10 - M12		-		-	160,16	JMXT6	174,71
JMX2	M3 - M4 - M5 - M6 M8 - M10 - M12		-		2.5/3.3/4.2/5.0/6.8/8.5/10.2 mm	198,98	JMXT2	213,53
JMX8	-		M3 - M4 - M5 - M6 M8 - M10 - M12		-	182,77	JMXT8	201,50
JMX4	-		M3 - M4 - M5 - M6 M8 - M10 - M12		2.5/3.3/4.2/5.0/6.8/8.5/10.2 mm	221,57	JMXT4	240,29

1200
N/mm²

CONTEÚDO

	FORMA B	OX	 35°	OX	 HSSCo 5%	HSS V3 €		TINALOX €
JMMD6	M3 - M4 - M5 - M6 M8 - M10 - M12		-		-	145,58	JMMDT6	206,68
JMMD2	M3 - M4 - M5 - M6 M8 - M10 - M12		-		2.5/3.3/4.2/5.0/6.8/8.5/10.2 mm	184,39	JMMDT2	245,48
JMMD8	-		M3 - M4 - M5 - M6 M8 - M10 - M12		-	166,15	JMMDT8	238,33
JMMD4	-		M3 - M4 - M5 - M6 M8 - M10 - M12		2.5/3.3/4.2/5.0/6.8/8.5/10.2 mm	204,95	JMMDT4	277,13

MACHOS DE MÁQUINA EM ESTOJOS METÁLICOS



Ref. JMC2

CONTEÚDO

	FORMA B	TiCN	15°	TiCN	HSSCo 5%	HSS-PM €
JMC6	M3 - M4 - M5 - M6 - M8 - M10 - M12		-		-	247,65
JMC2	M3 - M4 - M5 - M6 - M8 - M10 - M12		-		2.5/3.3/4.2/5.0/6.8/8.5/10.2 mm	286,46
JMC8	-		M3 - M4 - M5 - M6 - M8 - M10 - M12		-	281,89
JMC4	-		M3 - M4 - M5 - M6 - M8 - M10 - M12		2.5/3.3/4.2/5.0/6.8/8.5/10.2 mm	320,70

TODO-O TERRENO

CONTEÚDO

	FORMA B	TiN	35°	TiN	HSSCo 5%	HSSCo 5% €
JMD6	M3 - M4 - M5 - M6 - M8 - M10 - M12		-		-	223,80
JMD2	M3 - M4 - M5 - M6 - M8 - M10 - M12		-		2.5/3.3/4.2/5.0/6.8/8.5/10.2 mm	262,61
JMD8	-		M3 - M4 - M5 - M6 - M8 - M10 - M12		-	252,38
JMD4	-		M3 - M4 - M5 - M6 - M8 - M10 - M12		2.5/3.3/4.2/5.0/6.8/8.5/10.2 mm	291,19

AI

CONTEÚDO

	DENTE ALTERNADO	BRILHANTE	2 CANAIS	BRILHANTE	HSS	HSSCo 5% €
JMAL6	M3 - M4 - M5 - M6 - M8 - M10 - M12		-		-	177,20
JMAL2	M3 - M4 - M5 - M6 - M8 - M10 - M12		-		2.5/3.3/4.2/5.0/6.8/8.5/10.2 mm	216,00
JMAL8	-		M3 - M4 - M5 - M6 - M8 - M10 - M12		-	175,22
JMAL4	-		M3 - M4 - M5 - M6 - M8 - M10 - M12		2.5/3.3/4.2/5.0/6.8/8.5/10.2 mm	214,03

MACHOS DE MÁQUINAS EM ESTOJOS

USO
GERAL

CONTEÚDO

	FORMA B	BRILHANTE	 35°	BRILHANTE	HSSCo 5%	€
PT01	M4 - M5 - M6 - M8 - M10	M4 - M5 - M6 - M8 - M10	M4 - M5 - M6 - M8 - M10	M4 - M5 - M6 - M8 - M10		135,91



Ref. PT01

Plus

CONTEÚDO

	FORMA B	BRILHANTE	 35°	BRILHANTE	HSS PM		TiN
PT02	M4 - M5 - M6 - M8 - M10	M4 - M5 - M6 - M8 - M10	M4 - M5 - M6 - M8 - M10	M4 - M5 - M6 - M8 - M10	170,97	PT03	251,09



Ref. PT03

INOX

CONTEÚDO

	FORMA B	OX	 35°	OX	HSS PM		TiN
PT05	M4 - M5 - M6 - M8 - M10	M4 - M5 - M6 - M8 - M10	M4 - M5 - M6 - M8 - M10	M4 - M5 - M6 - M8 - M10	224,65	PT13	239,07



Ref. PT05

1200
N/mm²

CONTEÚDO

	FORMA B	OX	 35°	OX	HSS V3		TINALOX
PT04	M4 - M5 - M6 - M8 - M10	M4 - M5 - M6 - M8 - M10	M4 - M5 - M6 - M8 - M10	M4 - M5 - M6 - M8 - M10	192,79	PT14	289,73



Ref. PT04

1400
N/mm²

CONTEÚDO

	FORMA B	TiCN	 15°	TiCN	HSS PM	€
PT11	M4 - M5 - M6 - M8 - M10	M4 - M5 - M6 - M8 - M10	M4 - M5 - M6 - M8 - M10	M4 - M5 - M6 - M8 - M10		349,27



Ref. PT11

MACHOS DE MÁQUINAS EM ESTOJOS

Al



Ref. PT06

CONTEÚDO

	DENTE ALTERNADO	2 CANAIS	HSSCo 5% €
PT06	M4 - M5 - M6 M8 - M10	M4 - M5 - M6 M8 - M10	213,14

FUNDIÇÃO



Ref. PT07

CONTEÚDO

	FORMA C	HSSCo 5% €
PT07	M4 - M5 - M6 - M8 - M10 M4 - M5 - M6 - M8 - M10	161,08

LATÃO



Ref. PT10

CONTEÚDO

	FORMA C	HSSCo 5% €
PT10	M4 - M5 - M6 - M8 - M10 M4 - M5 - M6 - M8 - M10	195,81

LAMINAÇÃO



Ref. PT08

CONTEÚDO

	LAMINAÇÃO	HSSCo 5% €
PT08	M4 - M5 - M6 - M8 - M10 M4 - M5 - M6 - M8 - M10	294,81

TOL 6G



Ref. PT09

CONTEÚDO

	TOL 6G	HSSCo 5% €
PT09	M4 - M5 - M6 - M8 - M10 M4 - M5 - M6 - M8 - M10	397,16

TOL 6G



Ref. PT12

CONTEÚDO

	FORMA B	35°	HSSCo 5% €
PT12	M4 - M5 - M6 M8 - M10	M4 - M5 - M6 M8 - M10	220,24

EXPOSITORES DE METACRILATO PARA MACHOS DE MÁQUINA

EXPOSITOR DE METACRILATO

MM-03

Composição: machos de máquina, serie normal.

HSSCo
5%

FORMA

Furos passantes, Ref. 2

B	M4	M5	M6	M8	M10	M12	M14
	5	10	10	10	10	5	4



Furos cegos, Ref. 4

35°	M4	M5	M6	M8	M10	M12	M14
	5	10	10	10	10	5	4

Dimensões: largo 240 x fundo 240 x altura 245 mm

2.091,99 €



Ref. MM-03



Ref. MM-04

EXPOSITOR DE METACRILATO

MM-04

Composição: Machos de máquina, Serie Plus.
Fabricados em aço sinterizado.HSS
PM

Plus

FORMA

Furos passantes, Ref. 2

B	M4	M5	M6	M8	M10	M12	M14
	5	10	10	10	10	5	4



Furos cegos, Ref. 4

35°	M4	M5	M6	M8	M10	M12	M14
	5	10	10	10	10	5	4

Dimensões: largo 240 x fundo 240 x altura 245 mm

2.854,15 €

EXPOSITOR DE METACRILATO

MM-05

Composição: machos de máquina para trabalhos especiais.

FORMA

B Furos passantes, Ref. 2

1200 N/mm ²	M4	M5	M6	M8	M10	M12	M14
	1	2	2	2	2	1	1

INOX	M4	M5	M6	M8	M10	M12	M14
	1	2	2	2	2	1	1

Al	M4	M5	M6	M8	M10	M12	M14
	1	2	2	2	2	1	1

TiN	M4	M5	M6	M8	M10	M12	M14
	1	2	2	2	2	1	1

1400 N/mm ²	M4	M5	M6	M8	M10	M12	M14
	1	2	2	2	2	1	1



Furos cegos, Ref. 4

1200 N/mm ²	M4	M5	M6	M8	M10	M12	M14
	1	2	2	2	2	1	1

INOX	M4	M5	M6	M8	M10	M12	M14
	1	2	2	2	2	1	1

Al	M4	M5	M6	M8	M10	M12	M14
	1	2	2	2	2	1	1

TiN	M4	M5	M6	M8	M10	M12	M14
	1	2	2	2	2	1	1

1400 N/mm ²	M4	M5	M6	M8	M10	M12	M14
	1	2	2	2	2	1	1

Dimensões: largo 240 x fundo 240 x altura 245 mm

3.565,05 €